



BV-16

KNIFE GATE VALVE / WAFER TYPE

GENERAL FEATURES

Working Principle:

Gate valves; they perform their duties by opening and closing the fluid passage between the two sealing rings with a knife (slider) perpendicular to the transition direction. It is preferable to work fully open or fully closed. They are not suitable for precise flow control.

Application Areas and Sealing

It is a type of valve suitable for use in more fibrous fluids, eg paper industry and wastewater lines. It is fully sealed with one piece body and elastomer (EPDM, NBR, NR). It can also be produced according to its fluid properties.

It can be flywheel, gear box, chain wheel, pneumatic actuator and electric actuator. There is rising and non-rising alternatives.

On - Off Mechanism

Handle or Pneumatic Act.(opt.)

Advantages

- Full open valve provides a very low and smooth transition for flow.
- Flow can be in both direction.
- The valve can be installed in any position. However, it is preferable that the stem is perpendicular to the ground and the flywheel on top.
- Shorter valve length, even at large nominal diameters.
- Economically and conveniently available.
- There are types suitable for high pressures.
- Easy to maintain.

Flow Type

It is preferred to use in all fluids which can be called semi-solids.

Dimensions

From DN 50 to DN 600

Working Temperature

Between -10 °C to +110 °C

Body Material

GGG-40 Ductile Cast Iron

Pressure Class

PN16

Application Areas

- Paper Industry
- Petrochemical Industry-Treatment Plants
- Mining Sector
- Chemical Production Plants
- Food Industry

BV-16 KNIFE GATE VALVE / WAFER TYPE

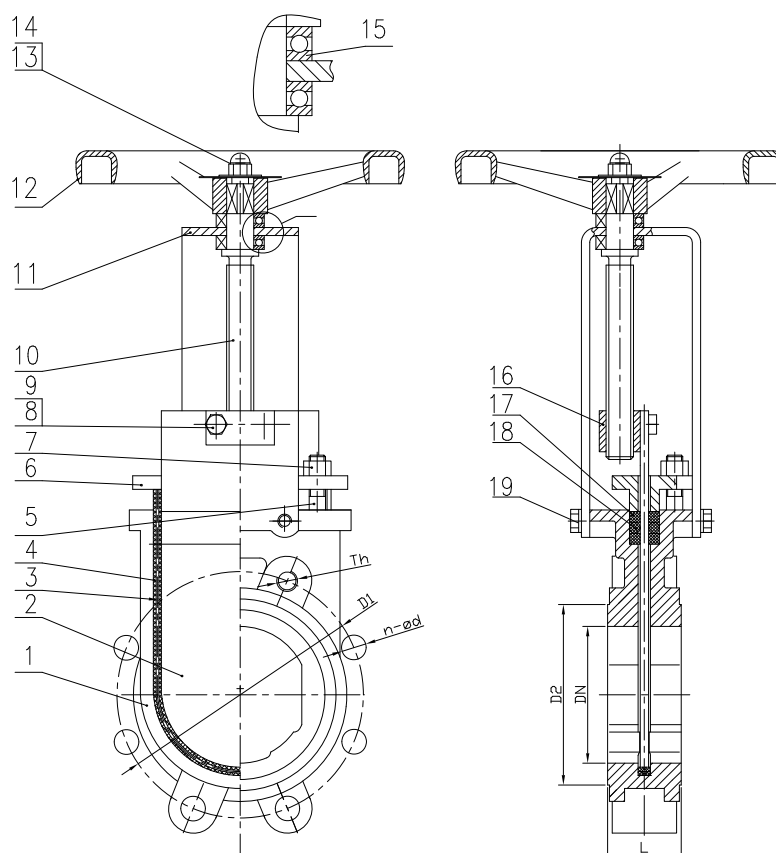

Part List		
No	Part	Material
1	Body	GGG40
2	Knife	SS304
3	Seat Ring	EPDM
4	Wire	SS201
5	Bolt	Carbon Steel + Zn
6	Gland	A216 WCB
7	Bolt Nut	Carbon Steel + Zn
8	Bolt	Carbon Steel + Zn
9	Bolt Nut	Carbon Steel + Zn
10	Stem	A276 304
11	Yoke	Q235A
12	Handwheel	A47 32510
13	Bolt	Carbon Steel + Zn
14	Lock Nut	Carbon Steel + Zn
15	Bearing	Threaded
16	Stem Nut	Brass
17	Packing	PTFE
18	O-ring	EPDM
19	Bolt	Carbon Steel+ Zn

DIAMETERS (mm)					
DN	D1	D2	n-Ød	Th	L
50	125	99	4-Ø19	M16	48
65	145	118	4-Ø19	M16	48
80	160	132	8-Ø19	M16	51
100	180	156	8-Ø19	M16	51
125	210	184	8-Ø19	M16	57
150	240	211	8-Ø23	M20	57
200	295	266	12-Ø23	M20	70
250	355	319	12-Ø28	M24	70
300	410	370	12-Ø28	M24	76
350	470	429	16-Ø28	M24	76
400	525	480	16-Ø31	M27	89

BV-16 KNIFE GATE VALVE / WAFER TYPE

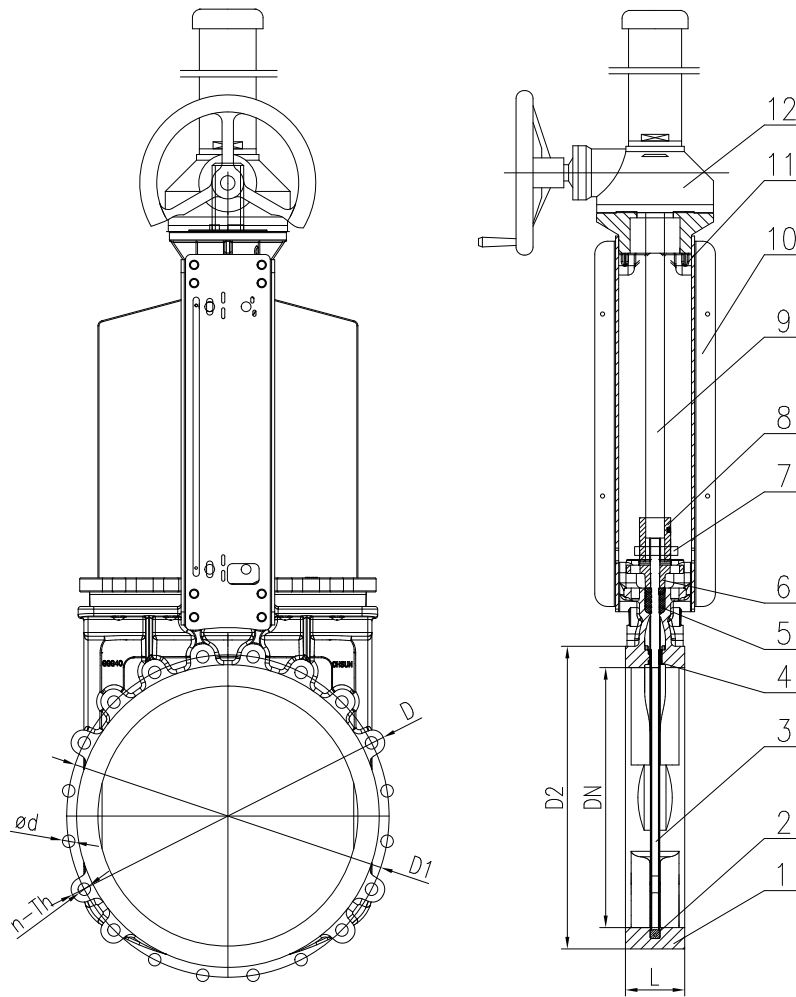

Part List		
No	Part	Material
1	Body	GGG40
2	Seal	EPDM
3	Knife	SS304
4	Guide Pad	PTFE
5	Packing	PTFE
6	Gland	A216 WCB
7	Cotter Pin	Carbon Steel
8	Chuck	A216 WCB
9	Stem	A276 WCB
10	Yoke	Q235A
11	Bolt-Nut	Carbon Steel + Zn
12	Gear Box	Assembly

DIAMETERS (mm)					
DN	D1	D2	n-Ød	Th	L
500	650	609	20-M30	Ø34	114
600	770	720	20-M33	Ø37	114



HEAD OFFICE - FACTORY

Atatürk Sanayi Bölgesi Hadımköy Mahallesi Mustafa 'nan Caddesi No: 44 Arnavutköy - ISTANBUL
 Tel: +90 212 771 01 45 (pbx) | Fax: +90 212 771 47 27
 info@ayvaz.com | www.ayvaz.com

Cona
Caserta/Italy
 Tel: +39 0823 187 3988
 rmolaro@ayvaz.com

Ayvaz Russia
Moscow/Russia
 Tel: +74959951728
 ayvazrus@ayvaz.com

Ayvaz Germany
Viernheim/Germany
 Tel: +49 62046014399
 germany@ayvaz.com

Ayvaz Ukraine
Kiev/Ukraine
 Tel: +380 44 390 57 57
 info@ayvaz.com.ua

Tricorr
Warsaw/Poland
 Tel: +48-32-783-295-1
 tricorr@tricorr.eu

Haci Ayvaz M.E.
Dubai/U.A.E
 Tel: +971 563550822
 +971 501306871
 mideast@ayvaz.com

Ayvaz China
Cixi City/China
 Tel: +86 0574 5897 3851
 info@ayvazchina.com

Ayvaz Kazakhstan LLP
Almaty/Kazakhstan
 Tel: +7 (727) 327 97 57
 info_kz@ayvaz.com
 www.ayvaz.kz

Ayvaz N
Isperih/Bulgaria
 Tel: +359 8431 27 32
 office@ayvaz-n.eu

Ayvaz Serbia
Belgrad/Serbia
 Tel: +381 61 658 70 52
 yakbiyik@ayvaz.com