

8 7 6 5 4 3 2 1

BILL OF MATERIALS

ITEM	QTY	PART NO.	DESCRIPTION	WEIGHT
1	1	0200WN0400	4" FIG 200 WING NUT	4.010
2	1	0200MT0400	4" FIG 200 MALE SUB THREAD	2.300
3	1	0200FT0400	4" FIG 200 FEMALE SUB THREAD	2.830

MATERIAL: A105
 HEAT TREATMENT : NORMALISING
 HARDNESS : 140-187 BHN

STANDARD CWP: 2000 PSI
 SOUR SERVICE CWP: 2000 PSI

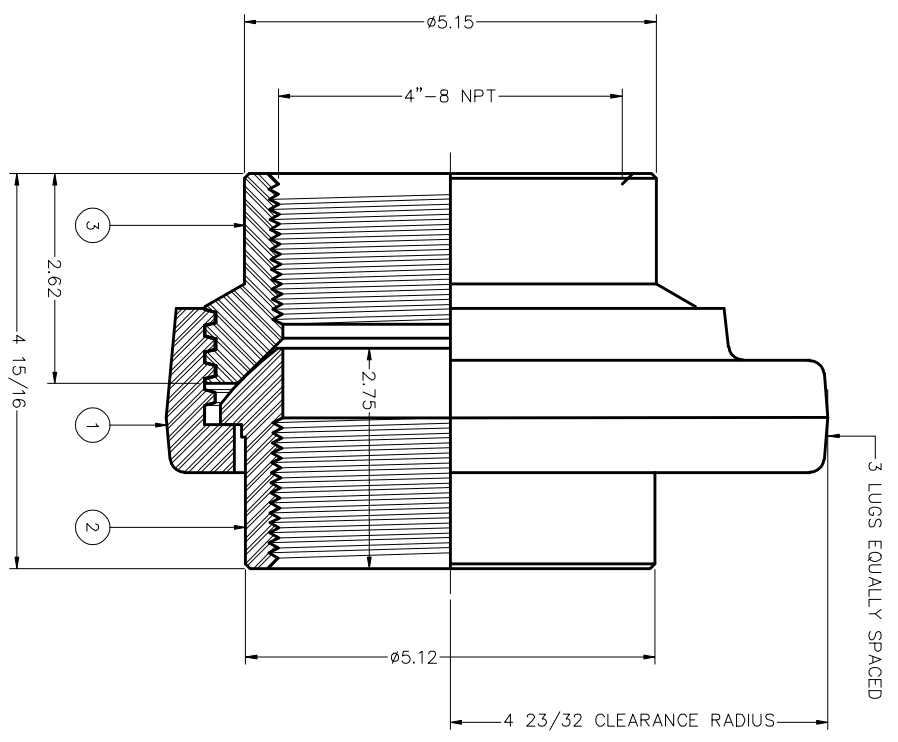

THIS DOCUMENT EMBODIES A CONFIDENTIAL, PROPRIETARY DESIGN OF WHICH AMERICAN BLOCK COMPANY RETAINS ALL PATENT AND OTHER RIGHTS, INCLUDING EXCLUSIVE RIGHT OF MANUFACTURE AND SALE. THIS DOCUMENT IS CONTROLLED UNDER AMERICAN BLOCK COMPANY'S PATENT RIGHTS AND IS NOT TO BE COPIED, REPRODUCED, OR MADE PUBLIC IN ANY MANNER WITHOUT THE WRITTEN PERMISSION OF AMERICAN BLOCK COMPANY.

REV.	DESCRIPTION	DATE	BY	CHKD	APPROV	TOLERANCES UNLESS SPECIFIED	ANGLES	SPRNG	DATE	ASSEMBLY THREADED	SHEET
0	REDRAWN	08/12	RBM	WKV		XXX ± .015 XXXX ± .005 ± 1/16	120° ± 1/2°	ORCAD RBM APPROV WKV SRS	19/06/10 19/06/10 19/06/10	4" FIG 200 HAMMER UNION 2000 PSI CWP	1 OF 1

ASSLY WEIGHT - 9.140 kg



8 7 6 5 4 3 2 1