

# E60H Series

## Hollow Shaft Type Ø60mm Incremental Rotary Encoder

### ■ Features

[Totem pole, NPN open collector, Voltage, Line driver output type]

- Ø60mm, Inner diameter of shaft Ø20mm
- Suitable for measuring angle, position, revolution, speed, acceleration and distance
- Power supply: 5VDC, 12-24VDC ±5%
- Various output types



[Analog sine wave OP Amp output type]

- Ø60mm, Inner diameter of shaft Ø20mm
- Power supply: 5VDC ±5%
- Analog sine wave OP Amp output



⚠ Please read "Safety Considerations" in the instruction manual before using.



### ■ Ordering Information

Series	Shaft inner diameter	Pulses/revolution	Output phase	Control output	Power supply	Cable
Ø60mm, hollow shaft type	Ø20mm	100, 1024, 5000, 8192	3: A, B, Z 6: A, $\bar{A}$ , B, $\bar{B}$ , Z, $\bar{Z}$	T: Totem pole output N: NPN open collector output V: Voltage output L: Line driver output	5: 5VDC ±5% 24: 12-24VDC ±5%	No mark: Radial cable type C: Radial cable connector type
Ø60mm, hollow shaft type	Ø20mm	2048	10: A, $\bar{A}$ , B, $\bar{B}$ , Z, $\bar{Z}$ , C, $\bar{C}$ , D, $\bar{D}$	A: Analog sine wave OP Amp output	5: 5VDC ±5%	R: Axial cable type S: Radial cable type



# E60H Series

## Control Output Diagram

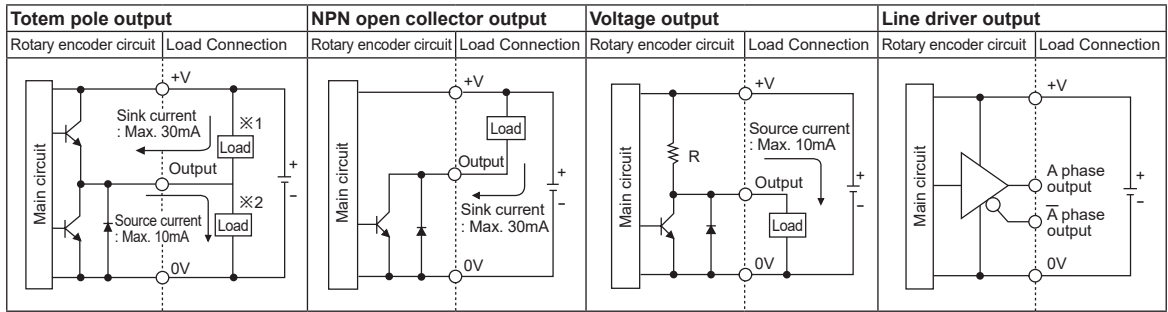

- All output circuits of A, B, Z phase are same. (line driver output is A,  $\bar{A}$ , B,  $\bar{B}$ , Z,  $\bar{Z}$ )
- Totem pole output type can be used for NPN open collector type (※1) or voltage output type (※2).

## Output Waveforms

### ⊙ Totem pole output / NPN open collector output / Voltage output

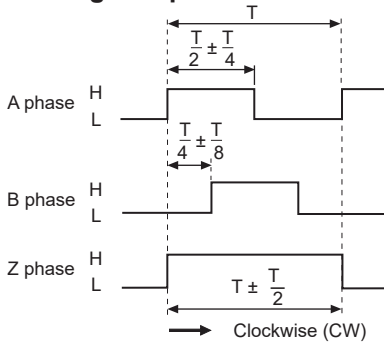

### ⊙ Line driver output

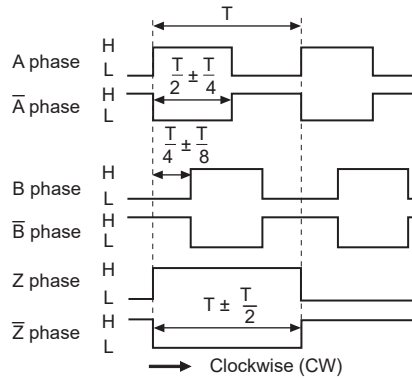

## Connections

### ⊙ Radial cable type

- Totem pole output / NPN open collector output / Voltage output

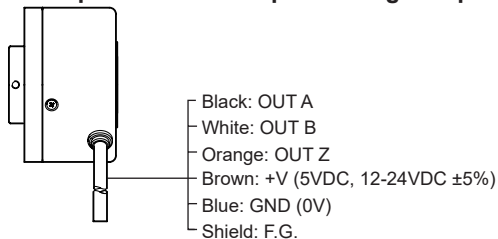

- Line driver output

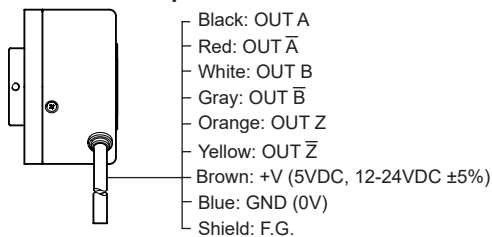

- ※ Unused wires must be insulated.
- ※ The metal case and shield cable of encoder should be grounded (F.G.).
- ※ Do not apply tensile strength over 30N to the cable.

### ⊙ Radial cable connector type

- Totem pole output / NPN open collector output / Voltage output
- Line driver output



Pin No.	Function	Cable color
1	OUT A	Black
2	OUT B	White
3	OUT Z	Orange
4	+V	Brown
5	GND	Blue
6	F.G.	Shield

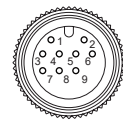

Pin No.	Function	Cable color
1	OUT A	Black
2	OUT $\bar{A}$	Red
3	+V	Brown
4	GND	Blue
5	OUT B	White
6	OUT $\bar{B}$	Gray
7	OUT Z	Orange
8	OUT $\bar{Z}$	Yellow
9	F.G.	Shield

- ※ F.G. (field ground): It should be grounded separately.

# Incremental Ø60mm Hollow Shaft type

## ■ Dimensions

(unit: mm)

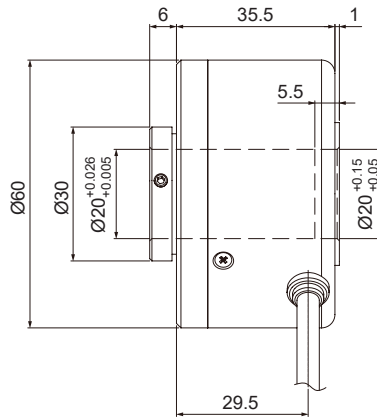
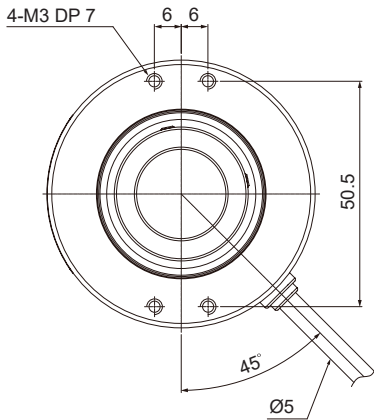

Cable for Radial cable type	Cable for radial cable connector type
Ø5mm, 5-wire (line driver output: 8-wire), Length: 2m, Shield cable	Ø5mm, 5-wire (line driver output: 8-wire), Length: 250mm, Shield cable

※Connector cable is sold separately and refer to the 'Connectors, Connector Cables, Sensor Distribution Boxes, Sockets' section.

## ◎ Bracket

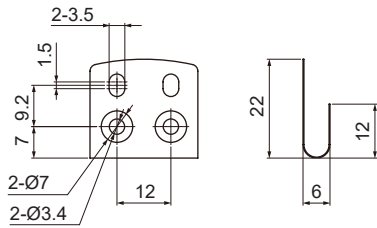

※Fix the unit by a wrench under 0.15 N·m of torque.

SENSORS

CONTROLLERS

MOTION DEVICES

SOFTWARE

(A) Photoelectric Sensors

(B) Fiber Optic Sensors

(C) LIDAR

(D) Door/Area Sensors

(E) Vision Sensors

(F) Proximity Sensors

(G) Pressure Sensors

(H) Rotary Encoders

(I) Connectors/ Connector Cables/ Sensor Distribution Boxes/ Sockets

# E60H Series

## Hollow Shaft Type Ø60mm Sine Wave Incremental Rotary Encoder

### ■ Specifications

Item		Hollow Shaft Type Ø60mm Sine Wave Incremental Rotary Encoder	
Model		E60H20-2048-10-A-5-R	E60H20-2048-10-A-5-S
Resolution (PPR)		2,048	
Output phase		A, $\bar{A}$ , B, $\bar{B}$ , Z, $\bar{Z}$ , C, $\bar{C}$ , D, $\bar{D}$ phase	
Phase difference of output		Phase difference between A and B: $\frac{T}{4} \pm \frac{T}{8}$ (T=1cycle of A phase) Phase difference between C and D: 90°	
Electrical specification	Control output	Output type	OP Amp output
		Output current	Max. 10mA
		Output voltage	$V_{p-p} \approx 0.5V \pm 0.1V$
		DC OFFSET	$V_{DC}: 2.5V \pm 0.3V$
	Max. response frequency	200kHz	
	Power supply	5VDC $\pm 5\%$ (ripple P-P: Max. 5%)	
	Current consumption	Max. 120mA (disconnection of the load)	
	Insulation resistance	Over 100MΩ (at 500VDC between all terminals and case)	
	Dielectric strength	750VAC 50/60Hz for 1 minute (between all terminals and case)	
	Connection	Axial cable type	Radial cable type
Mechanical specification	Starting torque	Max. 200gf·cm (0.02N·m)	
	Moment of inertia	Max. 110g·cm <sup>2</sup> ( $11 \times 10^{-6}$ kg·m <sup>2</sup> )	
	Shaft loading	Radial: 5kgf, Thrust: 2.5kgf	
	Max. allowable revolution	6000rpm	
Vibration		1.5mm amplitude at frequency of 10 to 55Hz in each X, Y, Z direction for 2 hours	
Shock		Approx. max. 100G	
Environment	Ambient temp.	-20 to 100°C, storage: -25 to 100°C	
	Ambient humi.	35 to 85%RH, storage: 35 to 90%RH	
Protection structure		IP40 (IEC standard)	
Cable		Ø6mm, 17-wire, 9m <sup>※1</sup> , Shield cable (AWG28, core diameter: 0.08mm, number of cores: 17, insulator out diameter: Ø0.8mm)	
Accessory		Bracket: 2	
Approval		CE	
Weight <sup>※2</sup>		Approx. 750g (approx. 720g)	

※1: Option is 7m, 15m.

※2: The weight includes packaging. The weight in parenthesis is for unit only.

※Environment resistance is rated at no freezing or condensation.

# Incremental Sine Wave Ø60mm Hollow Shaft Type

## Control Output Diagram

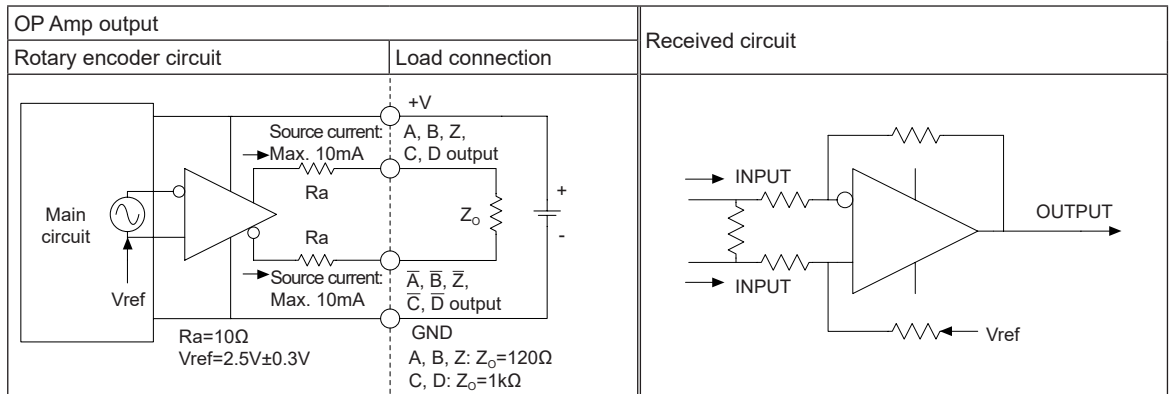

※All output circuits of A, A-bar, B, B-bar, Z, Z-bar, C, C-bar, D, D-bar phase are the same.

## Output Waveforms

### ○ A, A-bar, B, B-bar, Z, Z-bar phase

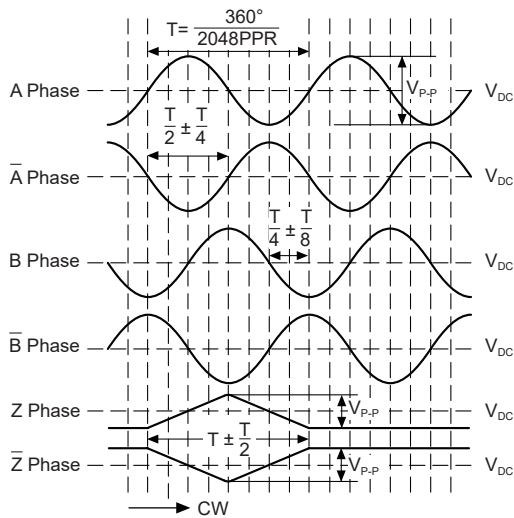

### ○ C, C-bar, D, D-bar phase

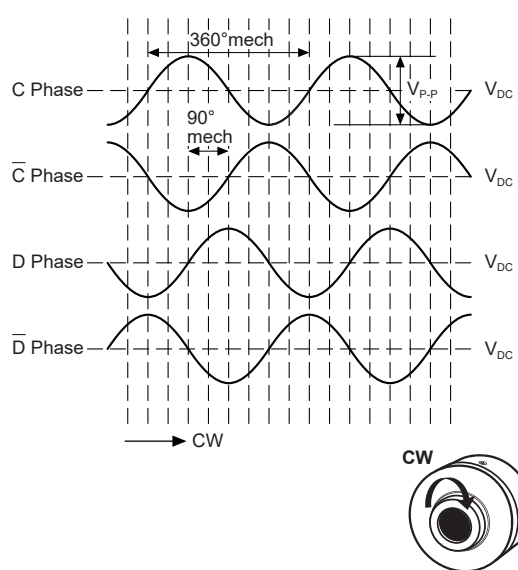

## Connections

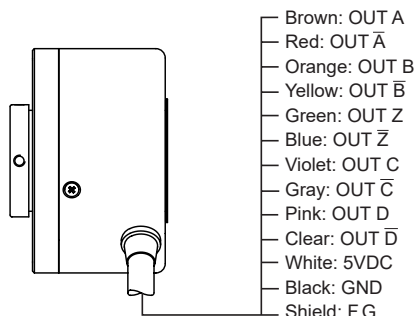

※Unused wires must be insulated.

※The metal case and shield cable of encoder should be grounded (F.G.).

※The output circuit has the dedicated IC and be sure not to short-circuit when wiring the output cables.

SENSORS

CONTROLLERS

MOTION DEVICES

SOFTWARE

(A) Photoelectric Sensors

(B) Fiber Optic Sensors

(C) LIDAR

(D) Door/Area Sensors

(E) Vision Sensors

(F) Proximity Sensors

(G) Pressure Sensors

(H) Rotary Encoders

(I) Connectors/ Connector Cables/ Sensor Distribution Boxes/ Sockets

# E60H Series

## ■ Dimensions

(unit: mm)

### ○ Axial cable type

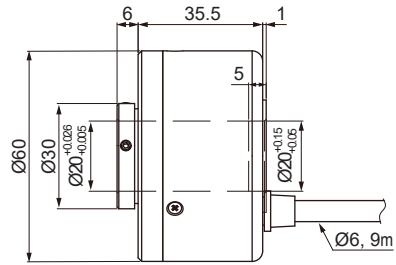
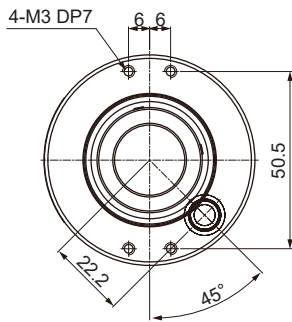

### ○ Radial cable type

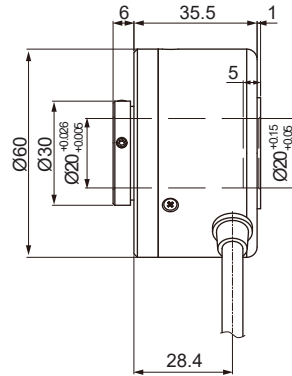
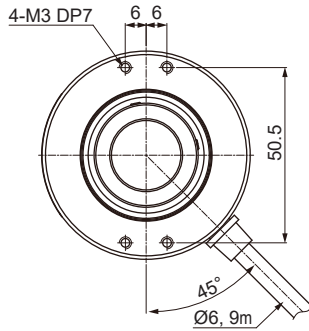

### ● Bracket

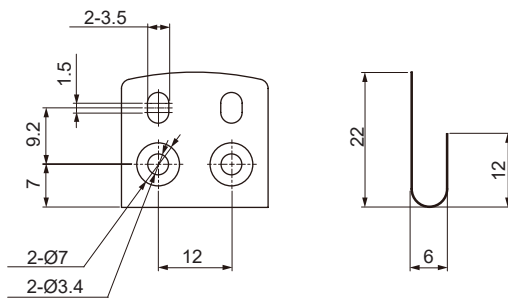

※Fix the unit by a wrench under 0.15 N·m of torque.