

## Data Sheet | Item Number: 855-301/075-201

Plug-in current transformer; Primary rated current: 75 A; Secondary rated current: 1 A; Rated power: 2.5 VA; Accuracy class: 1

<https://www.wago.com/855-301/075-201>

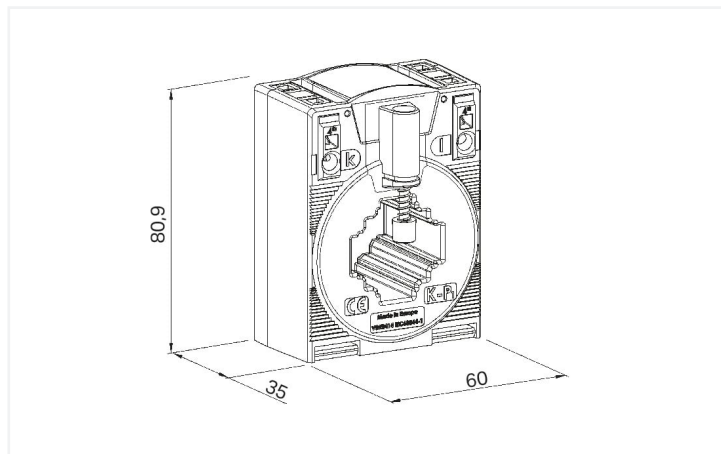

Dimensions in mm

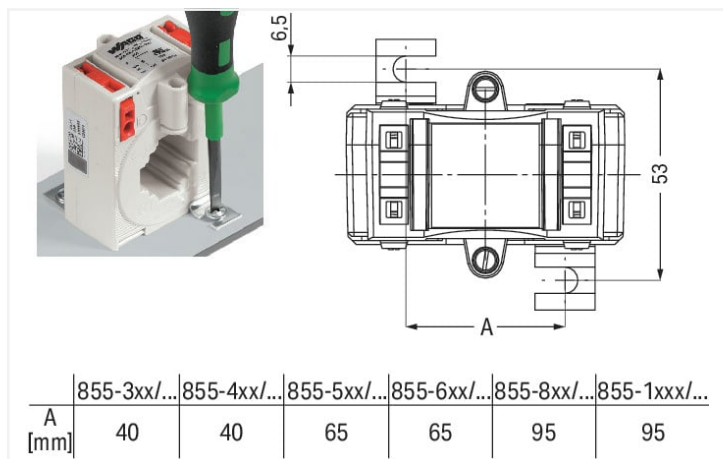

Dimensions in mm

### Short description:

These plug-in units (855 Series) are inductive, single-conductor current transformers. Due to the measurement principle used, these current transformers are exclusively designed for AC network applications. **Features:**

- Screwless CAGE CLAMP® connection technology
- Several mounting options available
- Vibration- and shock-resistant
- High mechanical retention forces
- High current-carrying capacity
- Continuous overload of 120% the nominal primary current
- Low-voltage current transformer for operating voltages up to max. 1.2 kV
- For 690 V power networks
- UL recognized components

### Technical data

#### Input current transformers

Primary rated current	75 A
Rated continuous thermal current $I_{cth}$	$1.2 \times I_N$
Rated short-time thermal current $I_{th}$	$60 \times I_N / 1 \text{ s (max. 100 kA / 1 s)}$
Overcurrent limiting factor	FS5 / FS10 (type dependent; see type plate inscription)
Rated frequency	50 ... 60 Hz

#### Output (current transformer)

Secondary rated current	1 A
Rated power $S_r$	2.5 VA

### Measurement error

Accuracy class	1
----------------	---

### Safety and protection

Highest voltage for equipment Um	AC 1.2 kV <sub>rms</sub>	<b>Test voltage</b>	
		Test voltage	AC 6 kV; 50 Hz; 1 min

### Connection data

Connection technology	CAGE CLAMP®
Solid conductor	0.08 ... 4 mm <sup>2</sup> / 28 ... 12 AWG
Fine-stranded conductor	0.08 ... 4 mm <sup>2</sup> / 28 ... 12 AWG
Strip length	9 ... 10 mm / 0.35 ... 0.39 inches

### Physical data

Width	60 mm / 2.362 inches
Height	80.9 mm / 3.185 inches
Depth	52 mm / 2.047 inches

### Mechanical data

Mounting type	Closed current transformer Installation on mounting plate Mounting on DIN-rail via DIN-rail adapter Installation on round cable
---------------	--

### Material data

Insulation class	E
Fire load	0 MJ
Weight	230 g

### Environmental requirements

Ambient temperature (operation)	-5 ... +50 °C
Ambient temperature (storage)	-25 ... +70 °C
Operating altitude (max.)	1000 m

### Standards and specifications

Conformity marking	CE
Standards/specifications	EN 61869-1 EN 61869-2 UL: E356480

**Commercial data**

eCl@ss 10.0	27-21-09-02
eCl@ss 9.0	27-21-09-02
ETIM 8.0	EC002048
ETIM 7.0	EC002048
PU (SPU)	1 pcs
Packaging type	Box
Country of origin	HU
GTIN	4050821616863
Customs tariff number	85043129900

**Environmental Product Compliance**

RoHS Compliance Status	Compliant, No Exemption
------------------------	-------------------------