

COMPANY PRESENTATION

ATMAS

*Experts in Civil Defense Shelters,
Blast & CBRN Protection*

www.atmas-tech.com
info@atmas-tech.com

May 2023



Presentation is for the addressee(s) only

Company Confidential: The contents of this presentation are intended solely for the addressee(s) and may contain confidential and/or privileged information and may be legally protected from disclosure. The content of the presentation and any of the pictures, information, or/and attachments is not intended for transfer or resending without prior approval from the official representative of Atmas Oy.

ABOUT ATMAS

Atmas provides a full range of products and services for protection, reinforcement and modernization of civil defense shelters and all types of government, industrial and private protective structures and facilities.

We offer consultancy, design and projects support, along with selection, supply and integration of various technology solutions for air filtration and air quality management, blast, ballistic, CBRN and EMP protection, decontamination, prefabricated security structures and other products for protecting people, infrastructure and emergency management.

WHY US?

- ✓ Wide range of solutions “under one roof”
- ✓ Professional and experienced team
- ✓ Flexible and customer-oriented approach
- ✓ Experts in international civil defense and protection standards
- ✓ Exclusive agreements with leading OEMs
- ✓ Global network of partners

FOUNDERS



Andrey Shpak
CEO

Andrey held various senior roles in leading global defense, homeland security and technology companies and has an extensive background in managing major government, military and industrial programs all around the world. Andrey specialize in the fields of land, air and naval platforms survivability, armored vehicles, strategic facilities protection, security, blast, ballistic and CBRN protection, civil defense and more.



Guy Zymann
Senior Advisor

Guy has over a decade of managerial experience (VP, CBDO and more) in the largest companies in the Civil Defense and Blast and CBRN protection sectors and brings a vast knowledge in the field of different markets, trends, and international standards, as well as working relationships with key players in this field, including senior decision-makers, advisors, engineers, design companies, and OEMs.

CONSULTANCY, DESIGN & PROJECTS SUPPORT

- Shelters, Reinforced Structures & Facilities new/modernization projects
- Protection Improvements Engineering Support

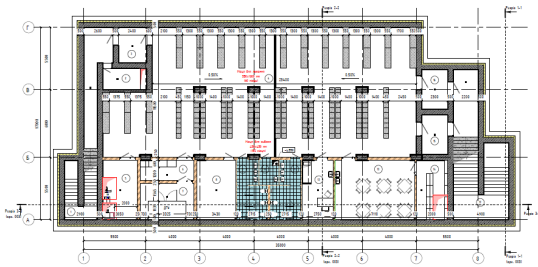

SYSTEMS SELECTION, SUPPLY & INTEGRATION

- Blast, Ballistic, CBRN, EMP Protective Solutions
- Air Supply & Life-Support Systems
- Security Systems

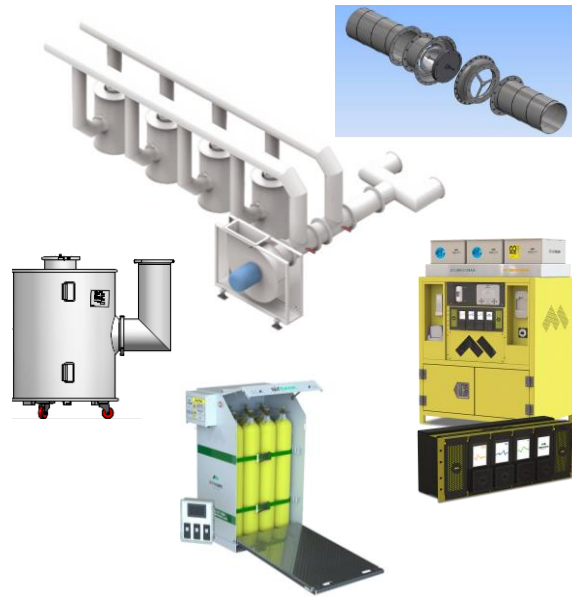

BLAST PROTECTION & STRUCTURES REINFORCEMENT

- Blast Doors, Gates, Windows
- Blast Mitigation & Reinforcement Solutions for Buildings and Structures

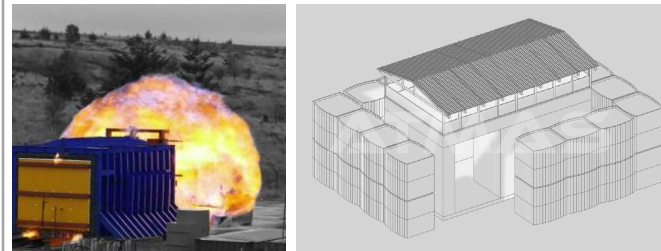

PRE-FABRICATED SHELTERS & BUILDINGS

- Modular Shelters
- Container Systems
- Protected Structures
- Refuge Chambers/Safe Haven



SERVICES

- Consultancy, Design, Equipment Selection & Projects Support

PRODUCTS

Protective & Life-support Systems

- CBRN Filtration & Ventilation Systems
- Carbon Dioxide (CO2) Removal and Oxygen (O2) Supply Systems
- Blast Doors, Gates and Windows, Blast Valves and more
- Blast & Ballistic Protection & Structural Reinforcement Solutions
- Electromagnetic Pulse Shielding Solutions

Pre-fabricated Shelters & Security Buildings

- Concrete made Shelters & Protective Structure
- Metal / Composite made Shelters
- Security Buildings & Protective Structures
- Refuge Chambers / Safe Havens

Safety & Security Systems

- CBRN Decontamination Systems & Materials
- Drugs & Explosive Detection Solutions

OUR PARTNERS



and more...

New Construction or Modernization Projects

- Protection Consultancy & Design
- Equipment Selection & Supply
- Project Support & Commissioning



**FROM CONCEPT
TO COMMISSIONING**

- ✓ Civil Defense Shelters
- ✓ Protective Facilities & Structures
- ✓ Critical Infrastructure
- ✓ Government / Industrial / Private Buildings

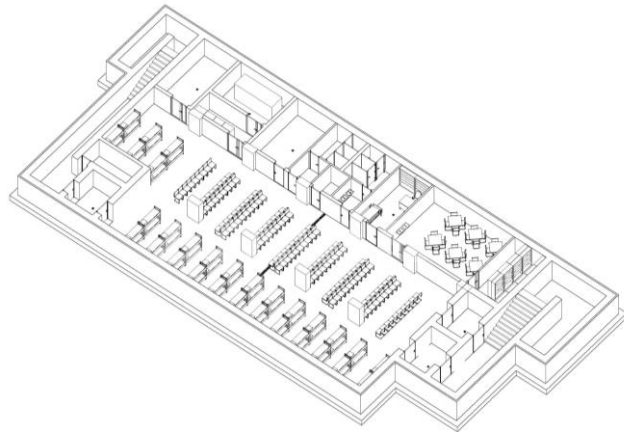

**Design project of
shelter for 250 people**

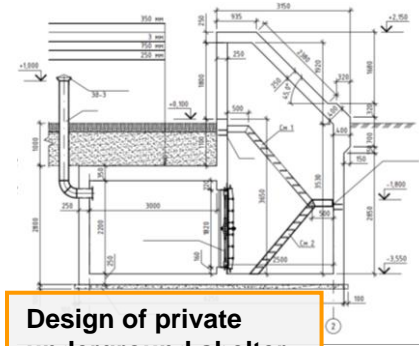
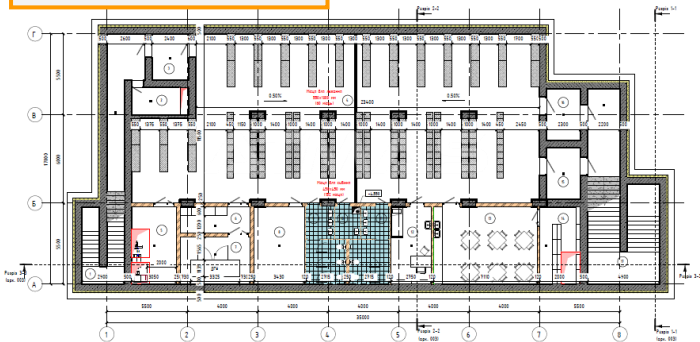

**Design of private
underground shelter**

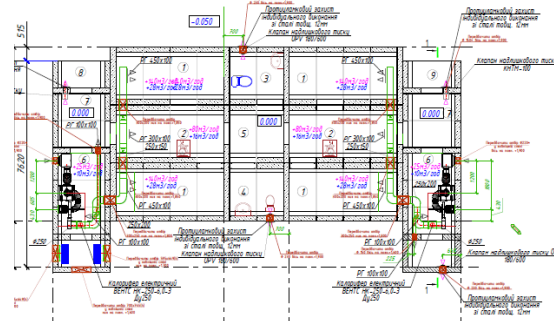
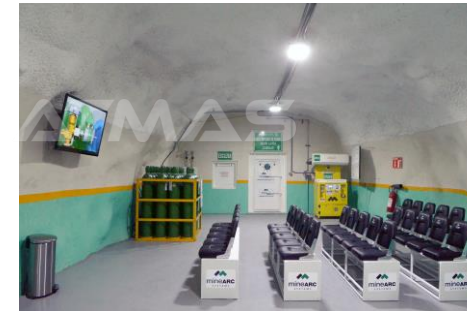
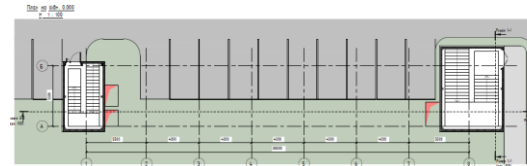

**Design project of ventilation
systems in the shelter**

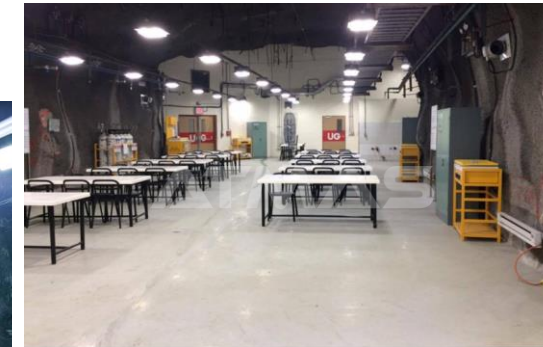

All types of NBC/CBRN Filtration Systems for Small, Medium & Large Shelters and Structures

Wide selection of chemical, biological, radiological and nuclear (CBRN) and toxic industrial chemicals (TIC) filtration systems* with airflows in range of 36-1,800 m³/h

*Complete set typically includes electric blower (optionally with manual backup), CBRN filter, blast valve/s, overpressure valve/s, prefilter and more.



CBRN Filtration Systems Installation Examples

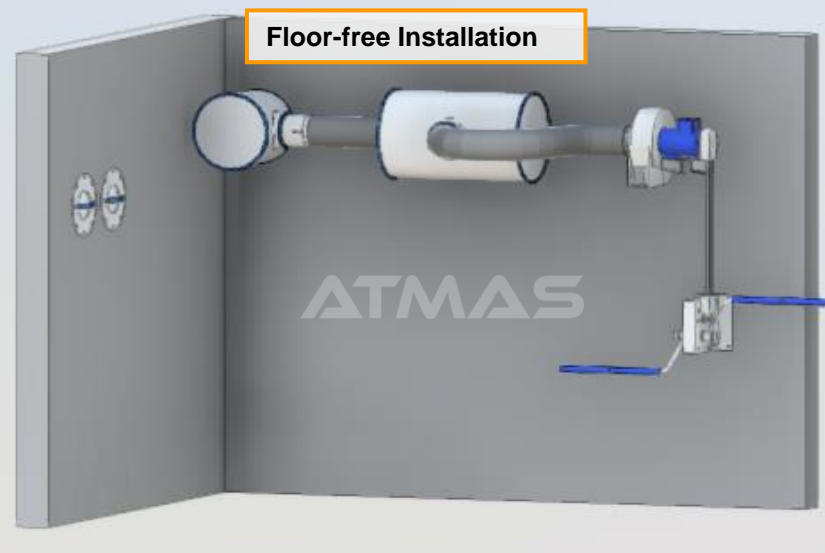
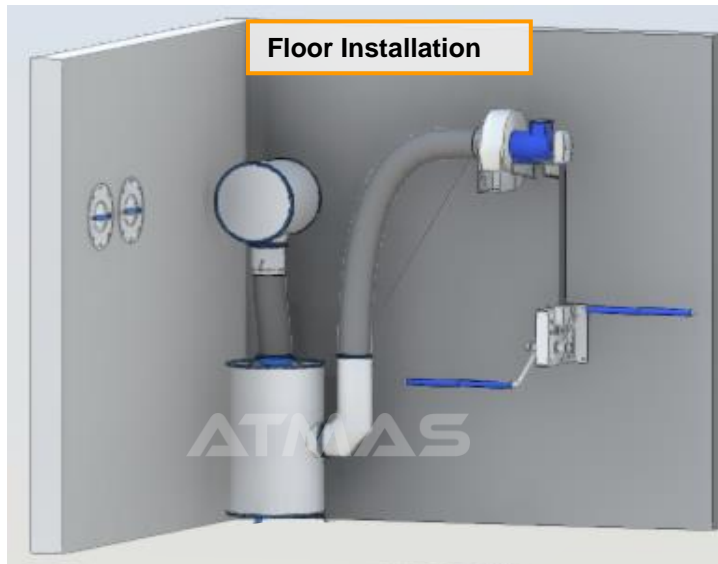

Filter Banks/Batteries – Modular CBRN Filtration Systems for Extra-large Shelters

Modular air filtration and supply systems specially designed to project requirement and protection standards.

- ✓ Can be designed for needed airflow and space, and equipped with a wide range of filters 600-1,800 m³/h
- ✓ Manual and automatic systems



Air Shaft Design with Blast Valves

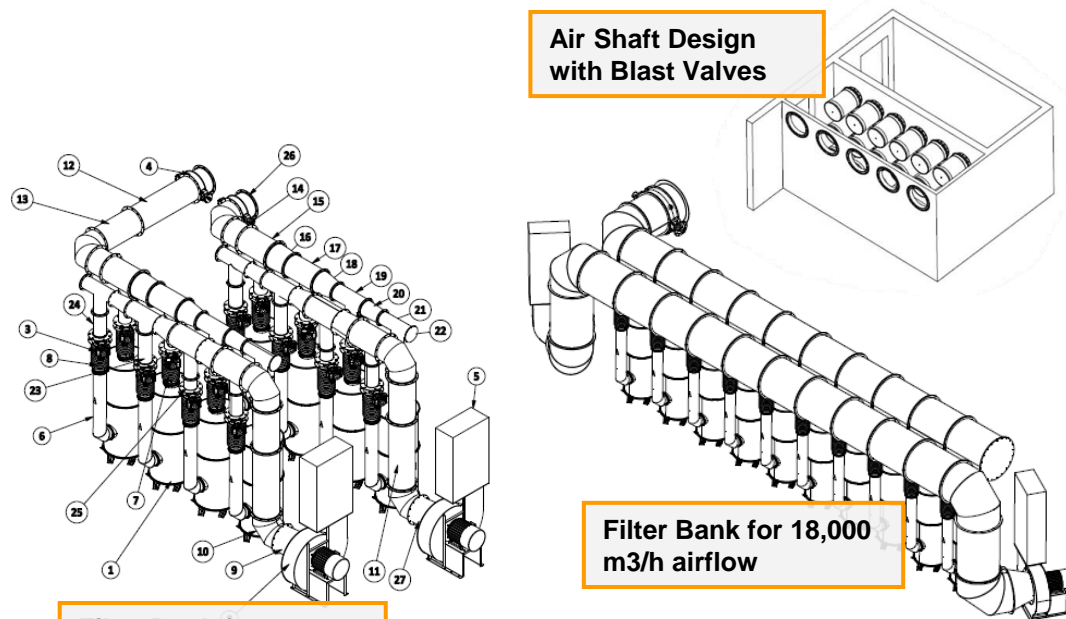

Filter Bank for 14,000 m³/h airflow

Filter Bank for 18,000 m³/h airflow

Filter Bank for 21,600 m³/h airflow

Specially Designed Eastern Europe Type Filters

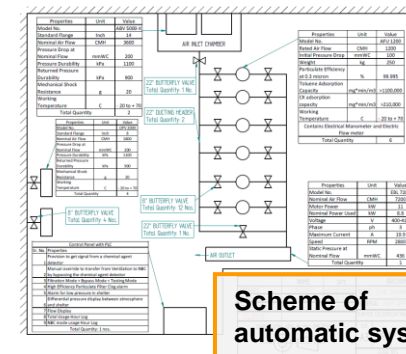

Scheme of automatic system

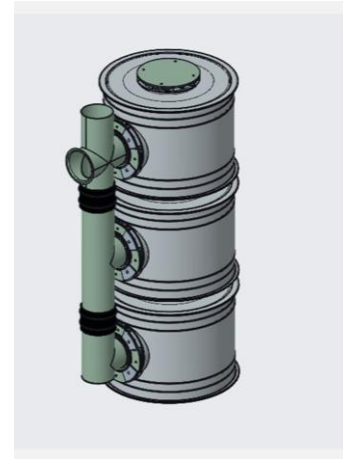

Air Supply Systems for Isolated Shelters/Spaces

- Carbon Dioxide (CO₂) Removal Systems (Scrubbers)
- Oxygen (O₂)/Air Supply & Overpressure Maintenance Systems
- Air Quality Control & Monitoring Systems



Air Quality Monitoring Systems



CO₂ / CO Removal Systems
Scrubbers for all Types of Shelters



Oxygen (O₂) supply & overpressure maintenance systems

- Blast Doors & Gates for Shelters, Storages & Industrial Facilities
- Blast Valves & Air Control Valves
- Barriers for Blast protection

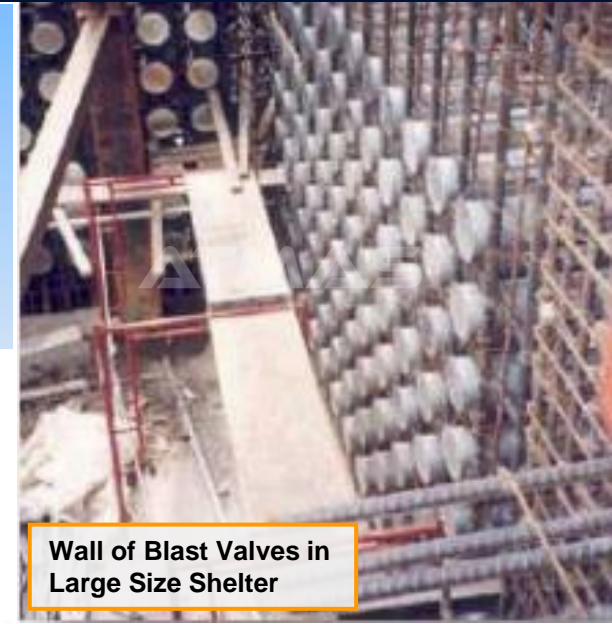

Blast doors for storages



Special design blast doors



Blast doors with concrete insert



Automated blast gates



Blast & gastight doors

Blast, Ballistic Mitigation & Reinforcement Solutions for any types of Shelters, Buildings & Structures – New Construction/Retrofit

- Structures
- Buildings
- Spaces



Protected Shelters



Blast mitigation fabric



Live blast test for brick wall with fabric reinforcement



Blast & Ballistic panels Retrofit



Live testing – structure reinforcement, protection from direct rocket hit



Internal Protective Structures for Structural Reinforcement and Blast Protection



Blast mitigation fabric installed on secured facility fence

- Blast Protection Solutions for Standard Windows - Retrofit
- Bulletproof Glass & Frames
- Protective Window Covers

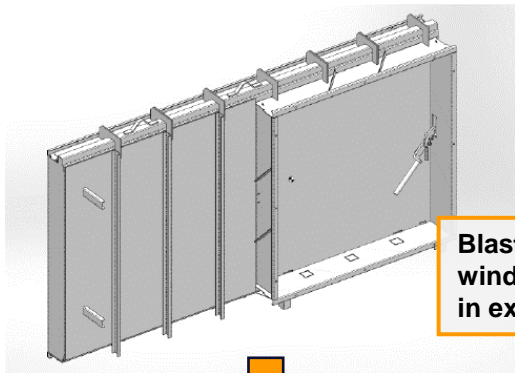

ELECTROMAGNETIC PULSE PROTECTION (EMP / EMPP)

- EMP Shielding of Critical Facilities
- EMP-shielded cabinets and containers

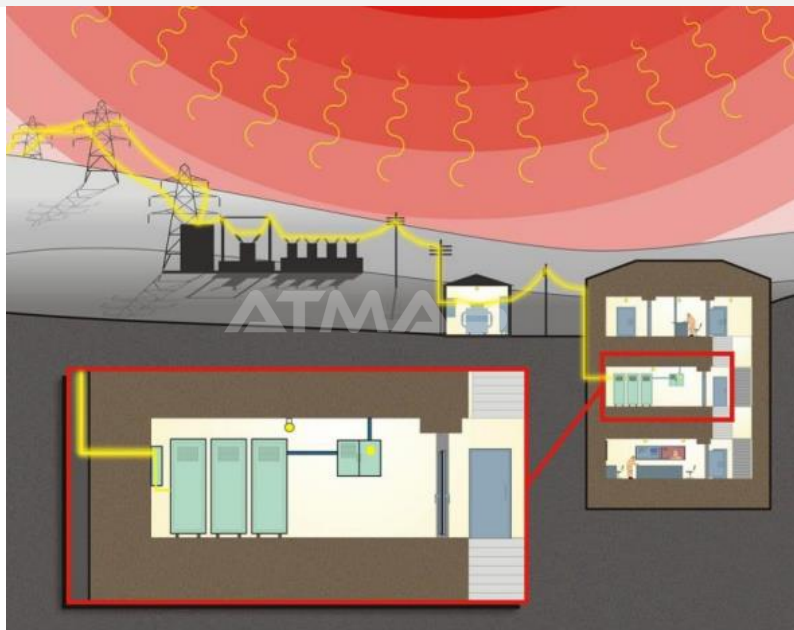

EMP shielded facilities

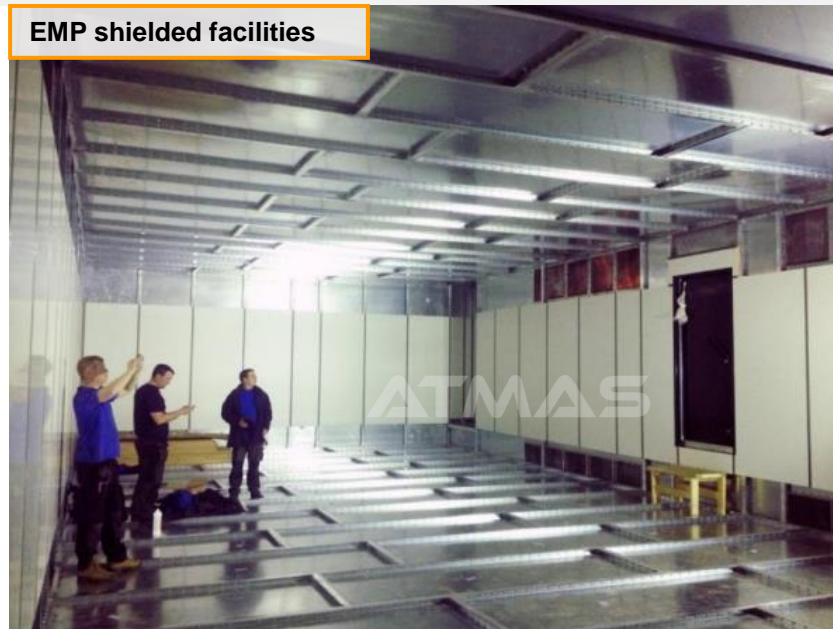

EMP-shielded cabinets



EMP filters



EMP shielded rooms

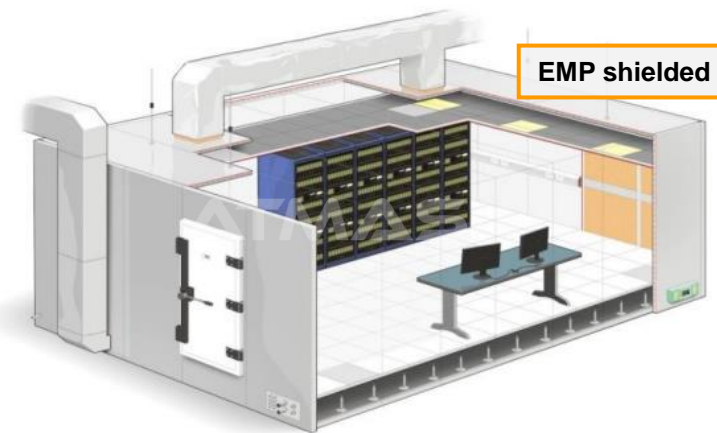

Upgrade of containers for EMP protection

INSTALLATION EXAMPLES

ATMAS

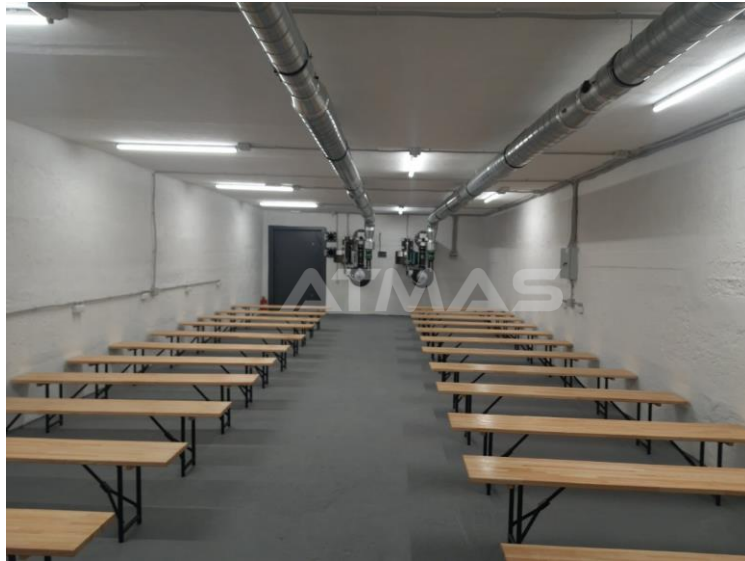

➤ All types of prefabricated on-the-ground and underground shelter solutions

Concrete prefabricated shelter

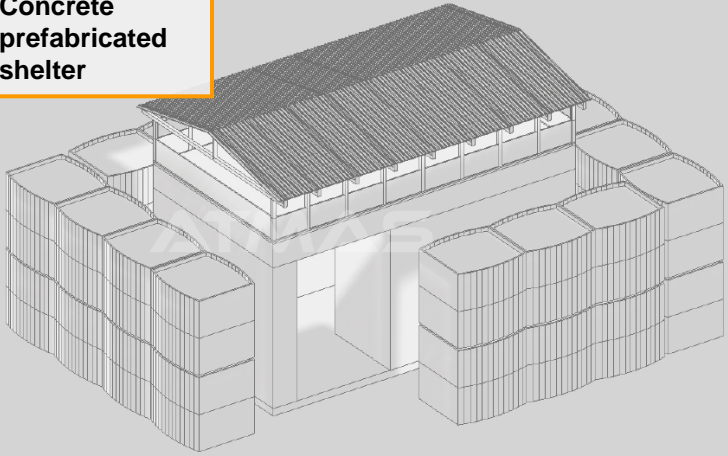

Protected shelter approved by MoD



Metal prefabricated shelter

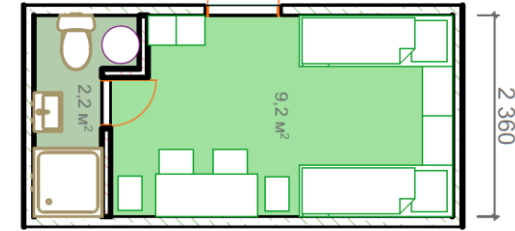

Underground shelter built from pre-fabricated modules

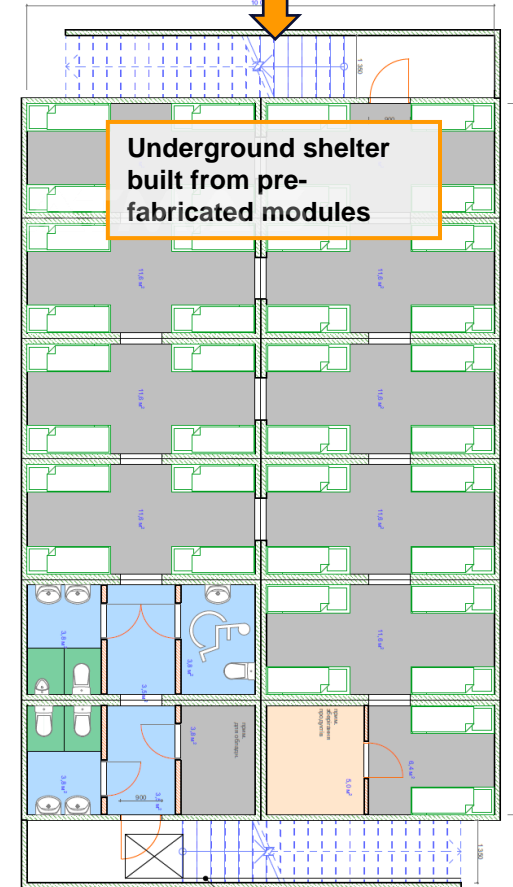

- **Modular Container Systems** for police, firefighters, military, medical, laboratories and more uses
- **Safe Havens and Refuge Chambers** for Mining, Petrochemical and other dangerous industries and spaces



Container systems



Expandable container



Mobile CBRN unit



Special Police container



Refuge chamber / safe haven in mine



Refuge chamber / safe haven

Blast / Ballistic / CBRN Protected Security Structures:

- Guard Posts & Towers
- Command & Control Centers
- Special Protective Structures



NCAGE: G1954



Various types of Security Structures



- Decontamination Tents & Containers
- Decontamination Equipment
- Decontamination Materials – Formula* (Non-Toxic):
 - ✓ Chemical Warfare Agents (CWA)
 - ✓ Biological Warfare Agents (BWA)
 - ✓ Toxic Industrial Chemicals (TIC)
 - ✓ Nonconventional Toxic Agents (NTA)
 - ✓ Radiological & Nuclear Particles (Clean-up)

**Patent (#19-11424) by Sandia National Labs – US Government Research and Development Laboratory*



Decontamination Shower

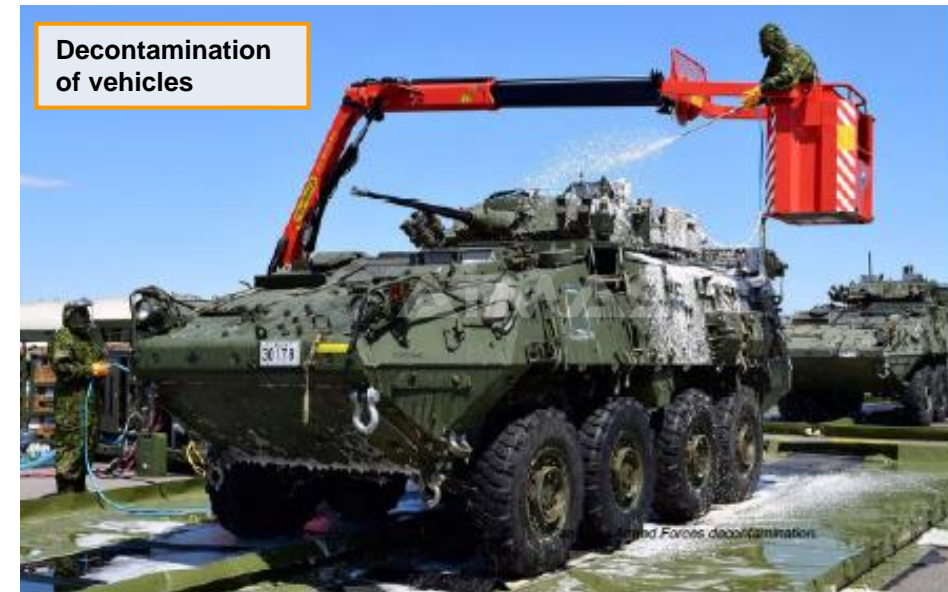

Decontamination of vehicles

Decontamination containers & systems

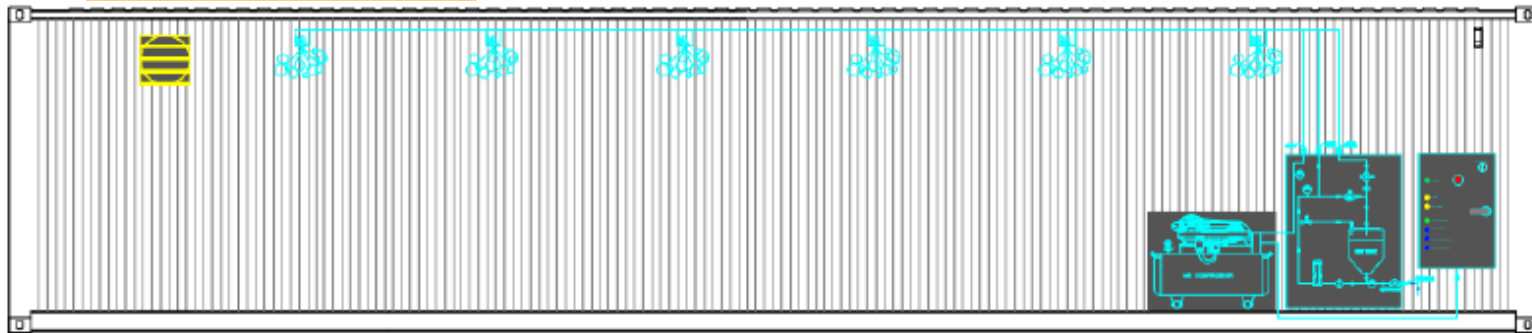

SIDE VIEW

Automated Decontamination & Disinfection Systems and other solutions based on unique formula

Decontamination and disinfection of transport



Decontamination and disinfection of medical & common use facilities



Decontamination laundry detergent



Oil spills treatment



Fire Suppressant aqueous film-forming foam



Contaminated water treatment



Services of Design, Engineering, Manufacturing (own design / built-to-print) and Special Assemblies for large and small quantities.

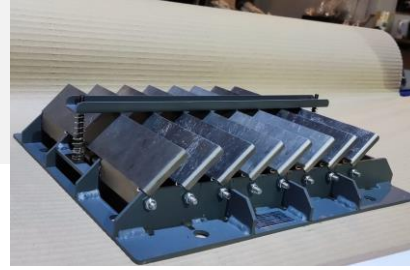

Contact us for questions or inquiries

Atmas

Address: Arielinkatu 10
00540 Helsinki
Finland

Tel.: +358 449843373

E-Mail: info@atmas-tech.com

Website: www.atmas-tech.com

Thank You!

ATMAS

