



www.ictgroup.com.tw

Contents

1. General Information.....	3
1-1. Model Number Configuration.....	3
1-2. Specifications.....	7
1-3. Dimensions.....	9
1-4. Harnesses Application.....	14
1-5. Bezel Styles.....	25
2. Installation.....	27
2-1. Download Firmware.....	27
2-2. Auto Testing Tool.....	32
2-3. Component Names.....	38
2-4. Assembling Procedure.....	39
3. Operation.....	53
3-1. Operation Flow Chart.....	53
3-2. I/O Circuits.....	54
4. Maintenance.....	60
5. Trouble Shooting.....	61
5-1. Introduction.....	61
5-2. Failed to Power Up.....	62
5-3. Failed to Communicate.....	63
5-4. Low Acceptance.....	64
5-5. Wrong Credit Output.....	65
5-6. Motor with Unfamiliar Sound.....	66
5-7. No Diagnostic LED Status.....	67
5-8. Bill Acceptor Error Code.....	68
5-8-1. One Flash.....	69
5-8-2. Two Flashes.....	70
5-8-3. Three Flashes.....	71
5-8-4. Three + Two Flashes.....	72
5-8-5. Three + Four Flashes.....	73
5-8-6. Four Flashes.....	74
5-8-7. Five Flashes.....	75
5-8-8. Six Flashes.....	76
5-8-9. Seven Blinks.....	77
6. Parts and Assembly Views.....	78
6-1. Exploded Views.....	78
6-2. Circuit Board Overview.....	88

Use of Materials Limitations

International Currency Technologies Corporation (ICT) all rights reserved.

All materials contained are the copyrighted property of ICT.

All trademarks, service marks, and trade names are proprietary to ICT.

ICT reserves the right at all times to disclose or to modify any information as ICT deems necessary to satisfy any applicable law, regulation, legal process or governmental request, or to edit, refuse to post or to remove any information or materials, in whole or in part, in ICT's sole discretion.

1. General Information :

1-1. Model Number Configuration

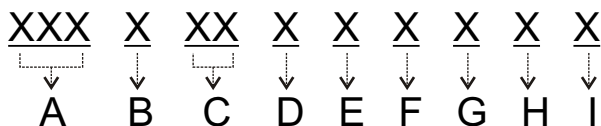

Ex. L70-BR600iA+

- A: Model
- B: Interface
- C: Currency Accepted
- D: Denomination
- E: Bill Box Capacity
- F: Type of Upper and Lower Base
- G: Internal Interface/ Plug-in Board Interface
- H: Bezel
- I: New Version

(A). Model :

Code	Type
L70	L70 (Bill Accepted Width 67.4mm~71mm)
L83	L83 (Bill Accepted Width 83mm)
L77	L77 (Bill Accepted Width 77mm)
PL77	PL77(Bill Accepted Width 77mm with P77 Marquee Bezel)

Table 1.

(B): Interface

Code	Interface
-	Pulse
2	RS232 (ICT002)
4	RS232 (ICT004)
6	RS232 (ICT006)
C	ccTalk
D	ID003
G	GBA
J	Parallel J
L	Parallel
M	MDB
N	CCNet
S	Pulse (for CPU Board of 3 in 1 Interface)
T	IGT (ID022) (for CPU Board of 3 in 1 Interface)

Table 2.

(C): Currency Accepted

Code	Country
AR	Argentina
BR	Brazil
RU	Russia
CO	Colombia
TW	Taiwan
CZ	Czech
EU	Europe Union
GB	United Kingdom
AY	Azerbaijan
CA	Canada
ID	Indonesia
PE	Peru
VN	Vietnam
TH	Thailand
CN	China
US	United States
BO	Bolivia
RO	Romania
UA	Ukraine

Table 3.

(D): Denomination

Code	Denomination
1	1 Denomination
2	2 Denomination
3	3 Denomination
4	4 Denomination
5	5 Denomination
6	6 Denomination
7	7 Denomination

Table 4.

(E): Bill Box Capacity

Code	Bill Box Capacity
0	No Bill Box
2	200 bills
3	300 bills
5	500 bills
6	600 bills

Table 5.

(F): Type of Upper and Lower Base

Code	Type
0	67.4mm
1	70mm
2	83mm
A	83mm + New Security Tooth
B	77mm + New Security Tooth

Table 6.

(G): Internal Interface/ Plug-in Board Interface

Code	Internal Interface/ Plug-in Interface Board
i	Internal Interface
e	Plug-in Interface Board

Table 7.

(H): Bezel

Code	Bezel
A	L70 Bezel 67.4 mm
B	L70 Bezel 71 mm
C	L83 Bezel 83 mm
D	L77 Bezel 77 mm
E	Bezel E 83 mm
F	Bezel F 83 mm
G	PL77 Bezel 77 mm

Table 8.

(I): New Version

Code	Internal Interface/ Plug-in Interface Board
+	New Software (System, Recognition, Tool) + New Hardware (CPU, LED, SEN)
#	Product Specification Upgrade

Table 9.

1-2. Specifications :

General

Acceptance Rate	96% or greater
<i>*Note: The Incomplete bills such as extremely dirty · wet · broken or wrinkled ones are excluded!</i>	
Bill Insertion	Four way acceptable
Transaction Time	Approx. 3 seconds to stack
Interface	<p>L70(#)-P2/P5: Pulse, RS232, ID003, MDB, CCNET.</p> <p>L70(IGT)-P2/P5: Pulse, RS232, IGT (ID022), ID003.</p> <p>L77-P3/P6: Pulse, GBA, RS232, ccTalk, MDB, Parallel, CCNET.</p> <p>L83-P3/P6: Pulse, GBA, RS232, ccTalk, MDB, Parallel, CCNET.</p> <p>PL77: Pulse, GBA, RS232, ccTalk, MDB, Parallel, CCNET.</p> <p>L83#-P3/P6: Pulse, GBA, RS232, CCNET, MDB.</p> <p>L77#-P3/P6: Pulse, GBA, RS232, CCNET, MDB.</p>
Installation	Indoor

Electrical

Power Source	<p>L70#/ L77#/ L83#: 12V DC(10~16V DC)</p> <p>Others: 12V DC(10.8~13.2V DC)</p>
Power Consumption	<p>Standby : 0.3A, 3.6W</p> <p>Operation: 1.2A, 14.4W</p> <p>Maximum: 2 A, 24 W</p>
Operation Environment	<p>Operating Temperature: L70/ L77/ L83/ PL77: 0°C~55°C</p> <p style="padding-left: 150px;">L70#/ L77#/ L83# : 0°C~65°C</p> <p>Storage Temperature: -20°C~70°C</p> <p>Humidity: 30%~85%RH (no condensation)</p>

Mechanical

Bill Accepted Width	L70(#)-P2/P5 : (67mm)-59mm~67mm (71mm)-59mm~71mm L77(#)-P3/P6 : 61mm~77mm L83(#)-P3/P6 : 61mm~83mm PL77 : 61mm~77mm
Bill Box Capacity	L70(#)-P2 : Approx. 200 bills L70(#)-P5 : Approx. 500 bills L77(#)-P3 : Approx. 300 bills L77(#)-P6 : Approx. 600 bills L83(#)-P3 : Approx. 300 bills L83(#)-P6 : Approx. 600 bills PL77 : Reserved
Weight	L70(#) : Approx. 0.52kg L70(#)-P2 : Approx. 1.25kg L70(#)-P5 : Approx. 1.4 kg L77(#) : Approx. 0.8 kg L77(#)-P3 : Approx. 1.46kg L77(#)-P6 : Approx. 1.65kg L83(#) : Approx. 0.8 kg L83(#)-P3 : Approx. 1.46kg L83(#)-P6 : Approx. 1.65kg PL77 : Approx. 0.8 kg
Outline Dimension	L70(#)-P2/P5 : Refer to page. 9 L77(#)-P3/P6 : Refer to page. 10 L83(#)-P3/P6 : Refer to page. 11 PL77 : Refer to page. 13

1-3. Dimensions :

L70(#)

Figure 1.

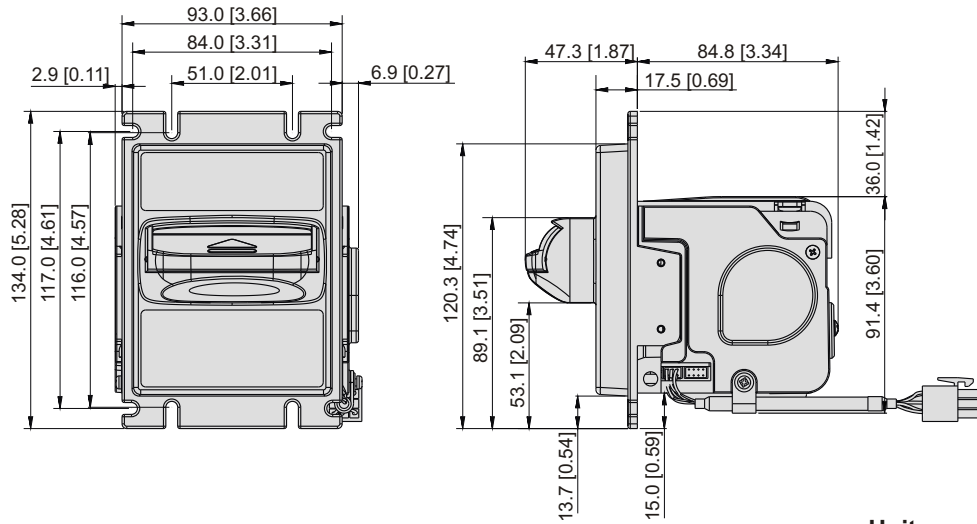

Unit : mm [inch]

L70(#)-P2/P5

Figure 2.

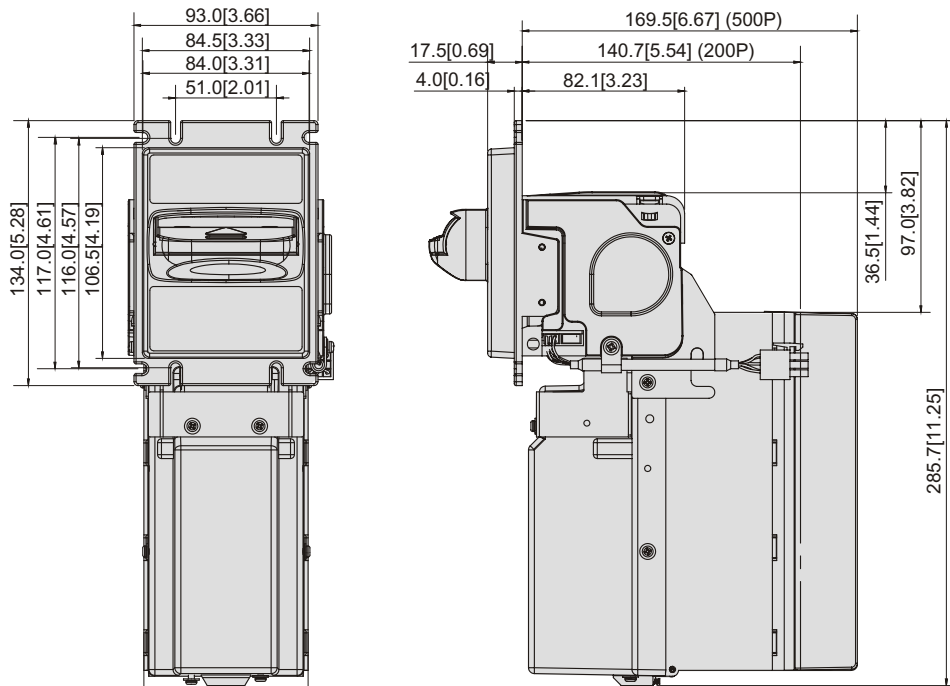

Unit : mm [inch]

L77(#)

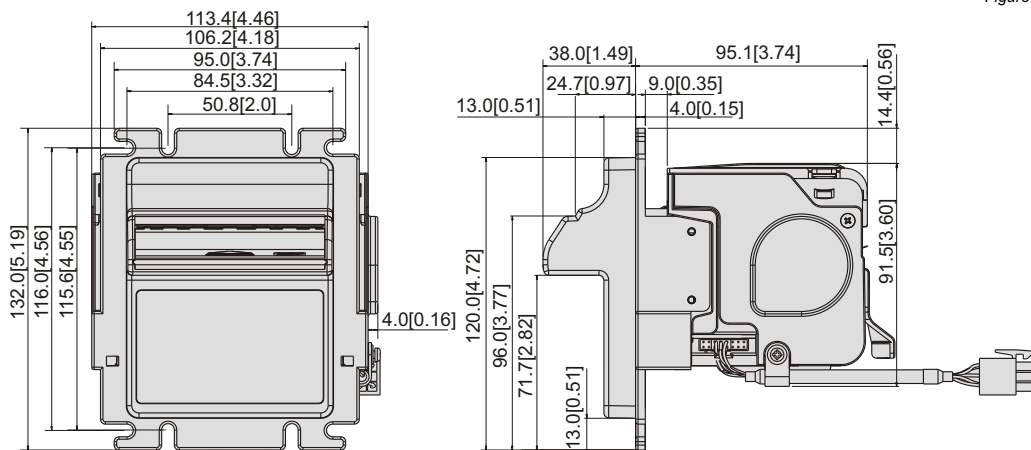

Figure 3.

Unit : mm [inch]

L77(#)-P3/P6

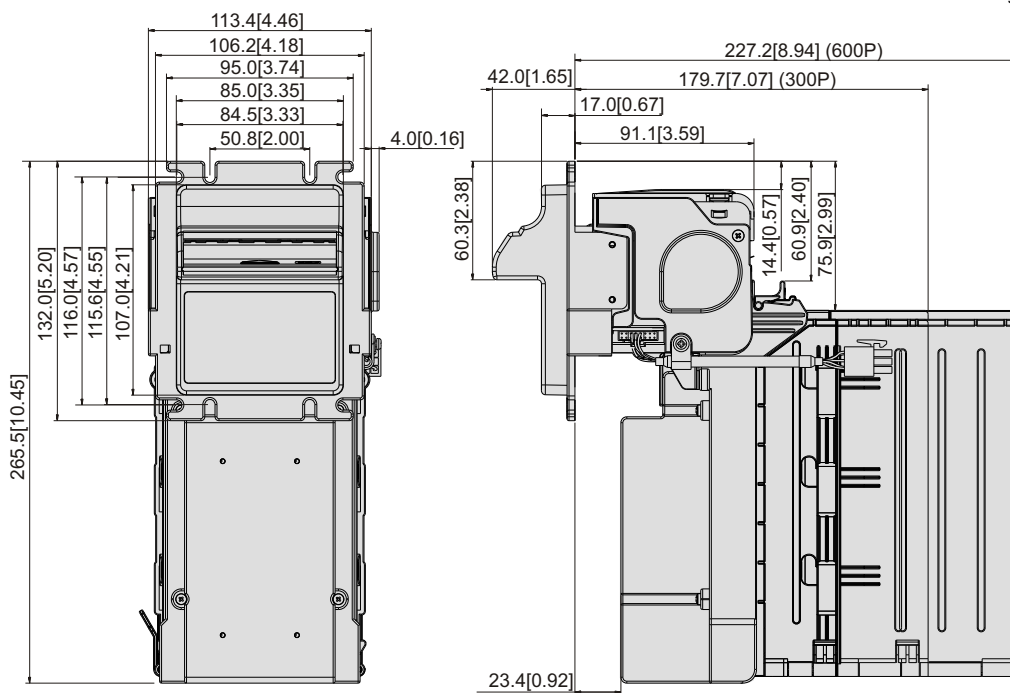
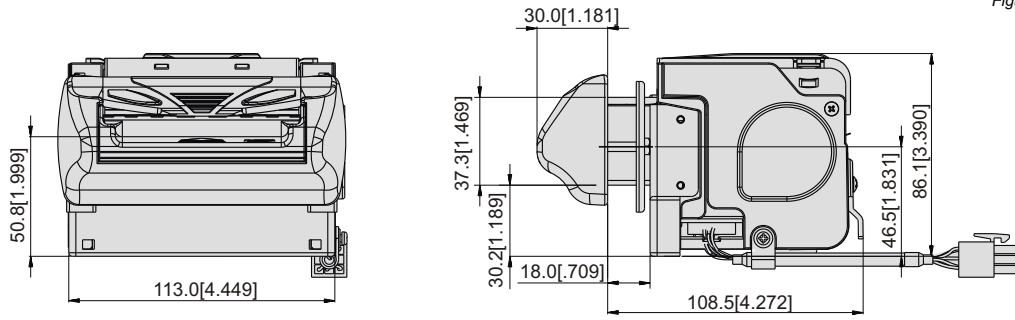

Figure 4.

Unit : mm [inch]

L83(#) Down Stacker

Figure 5.



Unit : mm [inch]

L83(#)-P3/P6 Down Stacker

Figure 6.

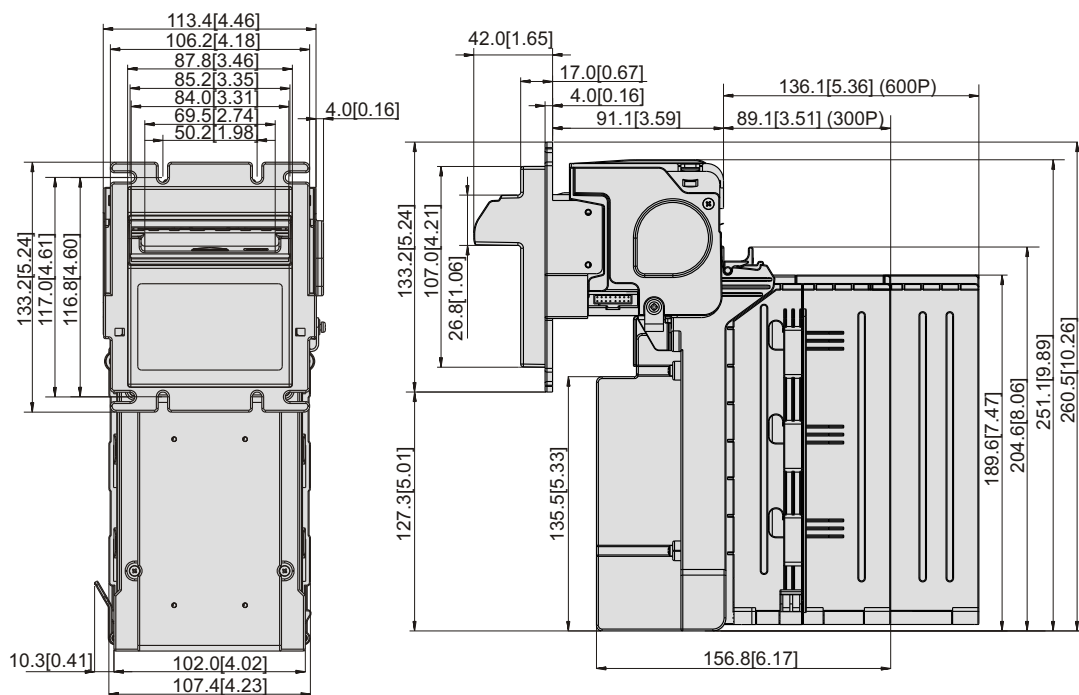

Unit : mm [inch]

L83(#) Up Stacker

Figure 7.

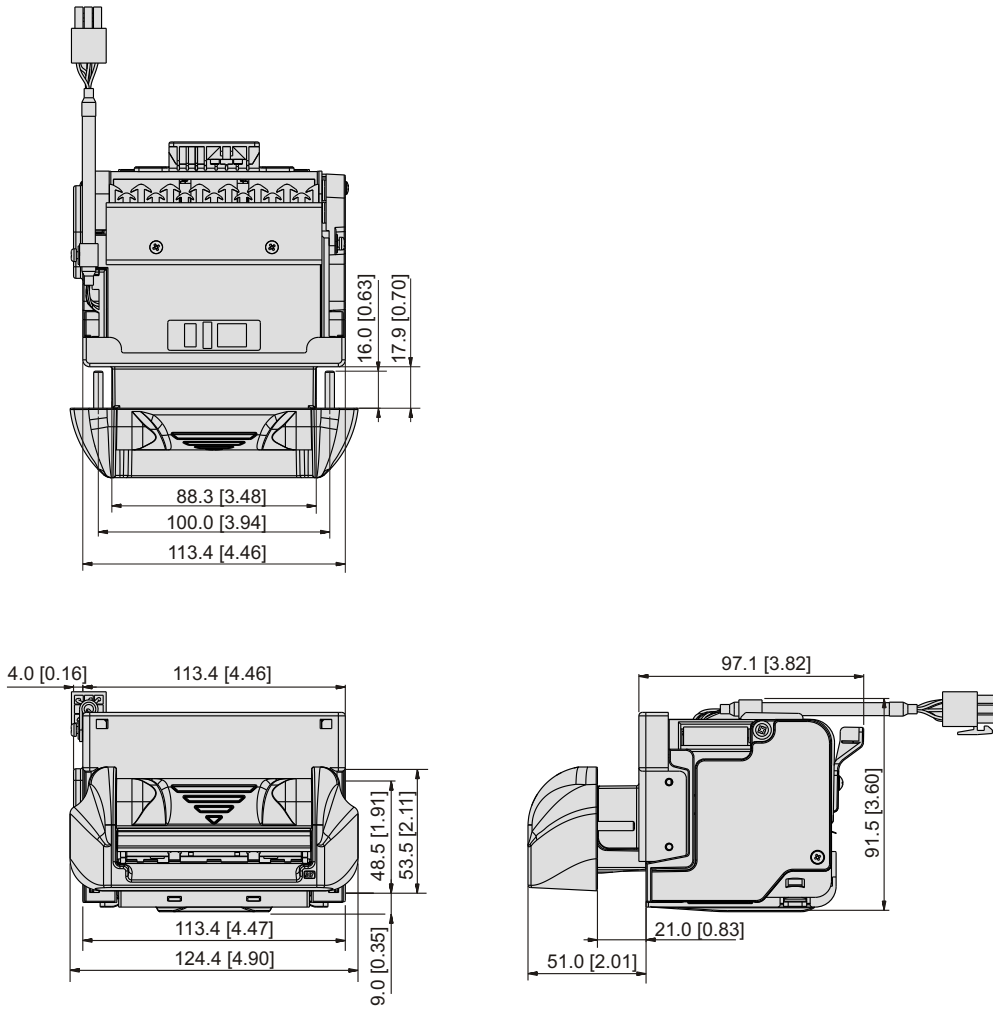

Unit : mm [inch]

PL77

Figure 8.

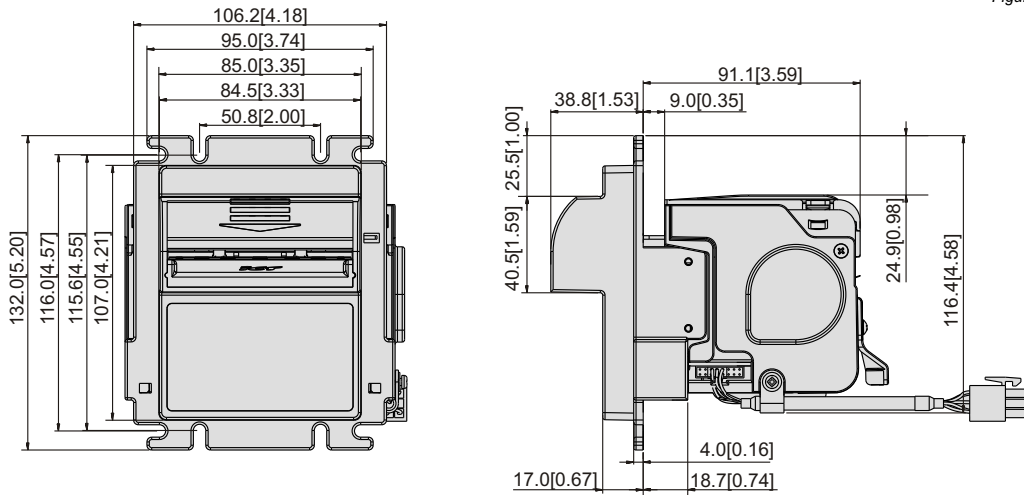

Unit : mm [inch]



To install the bill acceptor on your VMC, please be aware of the dimension as below:

[L] : Longer than the maximum length of accepted bills.

[L1] : Bill box capacity depth.

* [L/2] has to be longer than 70mm to open upper base.

Figure 9.

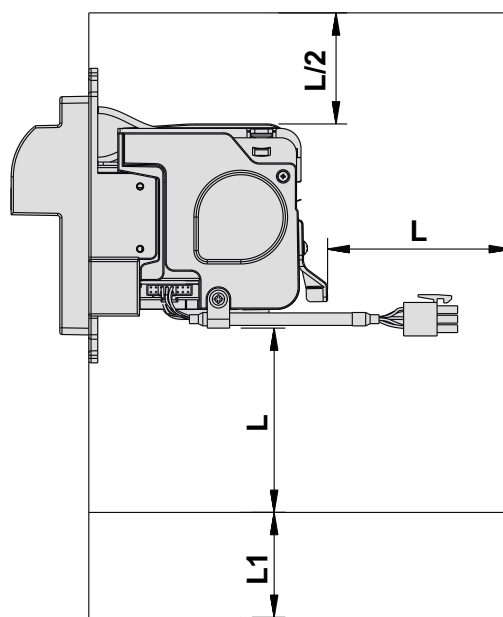

1-4. Harnesses Application:

Table 2.

Model	CPU Board	Interface	Used Voltage	Usage	Harnesses	Page
L70(#)-P2/P5	★6 2PCBAA318FXX (3 in 1)	Pulse	12V DC	Power & Data Comm.★3	WEL-RL702	16
				Extension Wire	CU-R961-1	16
		ICT (RS232)	12V DC	Power & Data Comm.	WEL-RL703 ★1	17
				IGT	12V DC	Power & Data Comm.
		ID003	12V DC	Extension Wire	WEL-R061	18
				Power & Data Comm.	WEL-RL705	18
	★6 2PCBAA318DXX (Non 3 in 1)	Pulse	12V DC	Power & Data Comm.	WEL-RL705	18
				Extension Wire	WEL-RID04	19
		ICT (RS232)	12V DC	Power	WEL-R7U02	19
				Extension Wire	CU-R961-1	16
				Data Comm.	WEL-R7U06 ★2	20
				Power	WEL-R7U02	19
		CCNET	12V DC	Extension Wire	CU-R961-1	16
				Data Comm.	WEL-R7U06	20
				Power	WEL-R7U02	19
		ID003	12V DC	Extension Wire	CU-R961-1	16
				Data Comm.	WEL-R7U06	20
				Power	WEL-R7U02	19
		MDB	★4 34V DC	Power & Data Comm. (BA↔Plug-in Board)★5	WEL-RBG01	20
				Power & Data Comm.(35cm) (Plug-in Board↔VMC)	WEL-RBG08	21
Power & Data Comm.(200cm) (Plug-in Board↔VMC)	WEL-RBG07			21		

- ★1. Internal use only. "Non 3 in 1" CPU Board is recommended for RS232 interface.
- ★2. WEL-R7U06: TTL Level to ±12VDC Level for PC.
- ★3. Data Comm.=Data Communication.
- ★4. MDB 34VDC: VMC Provides +34VDC to MDB Plug-in Board to convert into +12VDC, and provides +12VDC to L series bill acceptors.
- ★5. Plug-in Board: (New) 5RBG-AA313NA0-XX, (Old) 5RBG-AA266NA0-XX
- ★6. "XX" varies from board version to version.

Table 3.

Model	CPU Board	Interface	Used Voltage	Usage	Harnesses	Page	
L77-P3/P6 L83-P3/P6 PL77	2PCBAA324AXX ^{★6}	Pulse	12V DC	Power & Data Comm. ^{★3}	WEL-RL802	22	
				Extension Wire	CU-R961-1	16	
		ccTalk	12V DC	Power & Data Comm.	WEL-RL803	22	
				GBA	12V DC	Power & Data Comm.	WEL-RL805
		ICT (RS232)	12V DC		Power	WEL-RL802	22
					Extension Wire	CU-R961-1	16
					Data Comm.	WEL-R7U06 ^{★2}	19
		CCNET	12V DC		Power	WEL-RL802	22
					Extension Wire	CU-R961-1	16
					Data Comm.	WEL-R7U06	20
		MDB	34V DC		Power & Data Comm. (BA↔Plug-in Board)	WEL-RL812	23
					Power & Data Comm.(35cm) (Plug-in Board↔VMC)	WEL-RBG08	21
					Power & Data Comm.(200cm) (Plug-in Board↔VMC)	WEL-RBG07	21
Parallel	12V DC	Power & Data Comm.	WEL-RL804	24			
Parallel J	12V DC	Power & Data Comm.	WEL-RL806	24			
L77#-P3/P6 L83#-P3/P6	2PCBAA324AXX ^{★6}	Pulse	12V DC	Power & Data Comm	WEL-RL802	22	
				Extension Wire	CU-R961-1	16	
		GBA	12V DC	Power & Data Comm	WEL-RL805	23	
				ICT (RS232)	12V DC		Power
		Extension Wire	CU-R961-1				16
		Data Comm.	WEL-R7U06				19
		CCNET	12V DC		Power	WEL-RL802	22
					Extension Wire	CU-R961-1	16
					Data Comm.	WEL-R7U06	19
		MDB	34V DC ^{★4}		Power & Data Comm. (BA↔Plug-in Board) ^{★5}	WEL-RL812	23
					Power & Data Comm.(35cm) (Plug-in Board↔VMC)	WEL-RBG08	21
					Power & Data Comm.(200cm) (Plug-in Board↔VMC)	WEL-RBG07	21

★2. WEL-R7U06: TTL Level to ±12VDC Level for PC.

★3. Data Comm.=Data Communication.

★4. MDB 34VDC: VMC Provides +34VDC to MDB Plug-in Board to convert into +12VDC, and provides +12VDC to L series bill acceptors.

★5. Plug-in Board: (New) 5RBG-AA313NA0-XX, (Old) 5RBG-AA266NA0-XX

★6. "XX" varies from board version to version.

Figure 10.

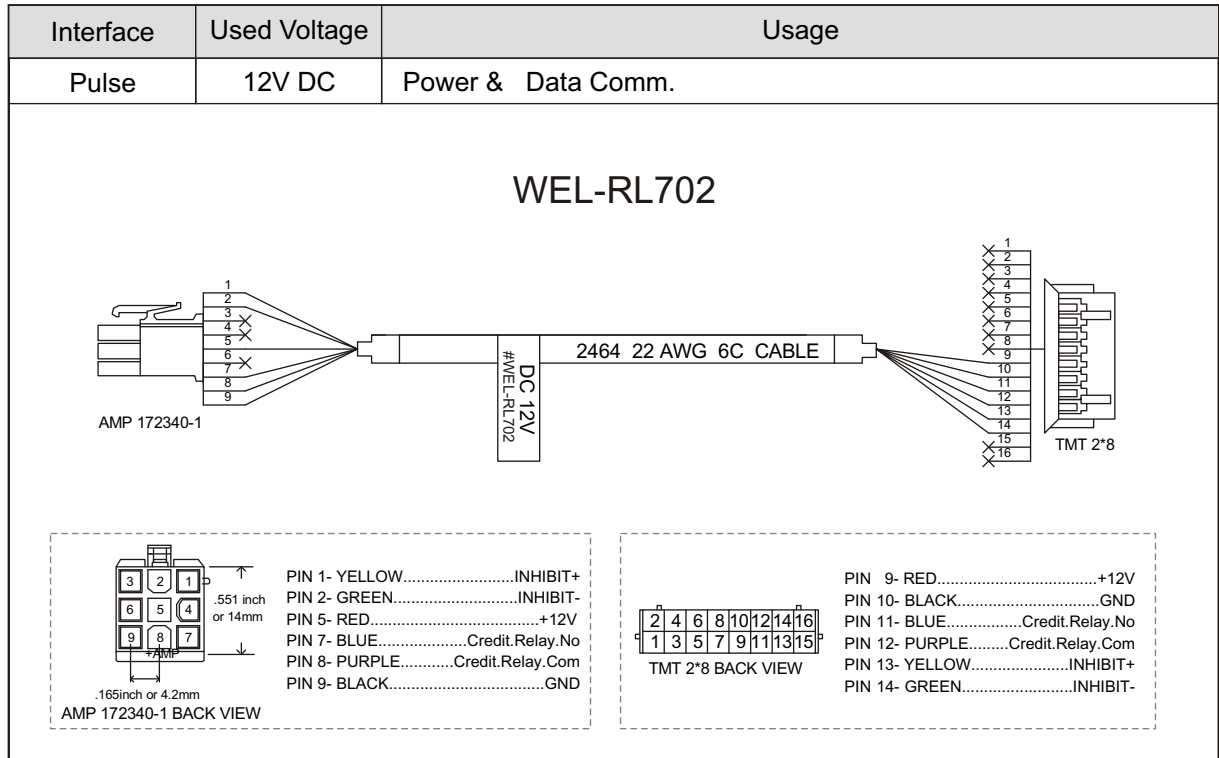

Figure 11.

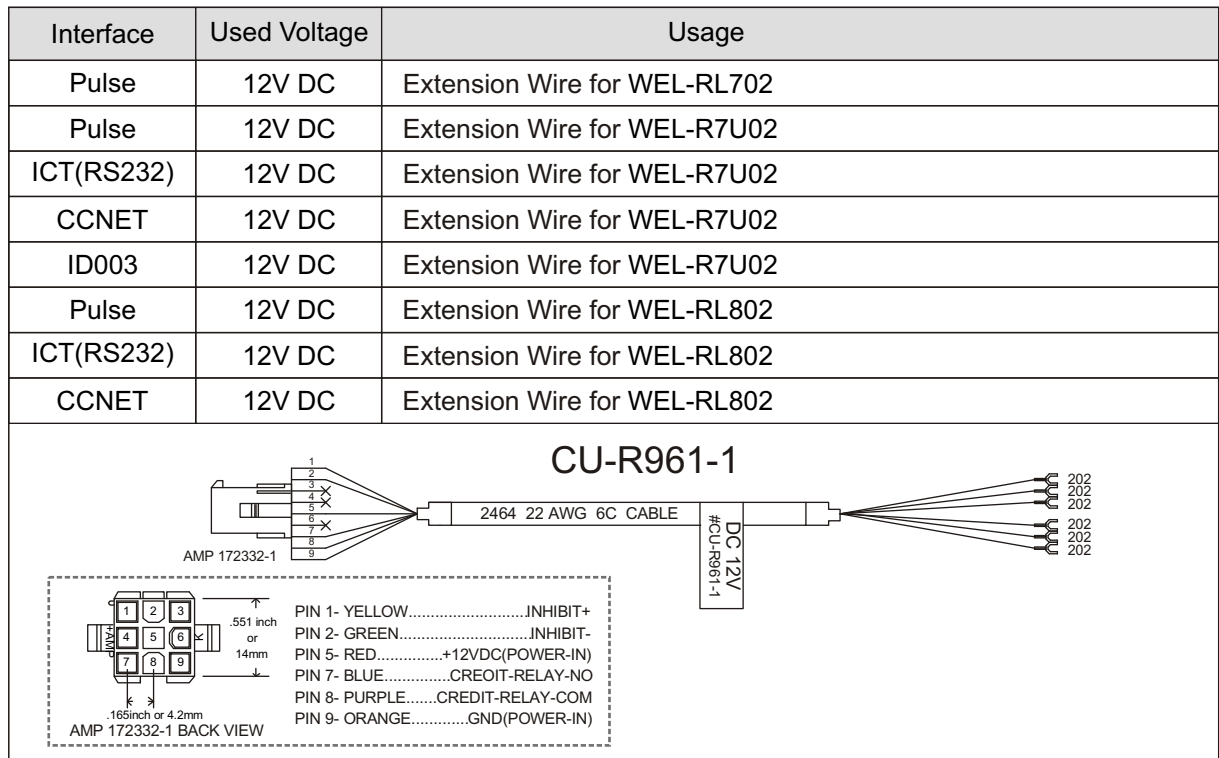

Figure 12.

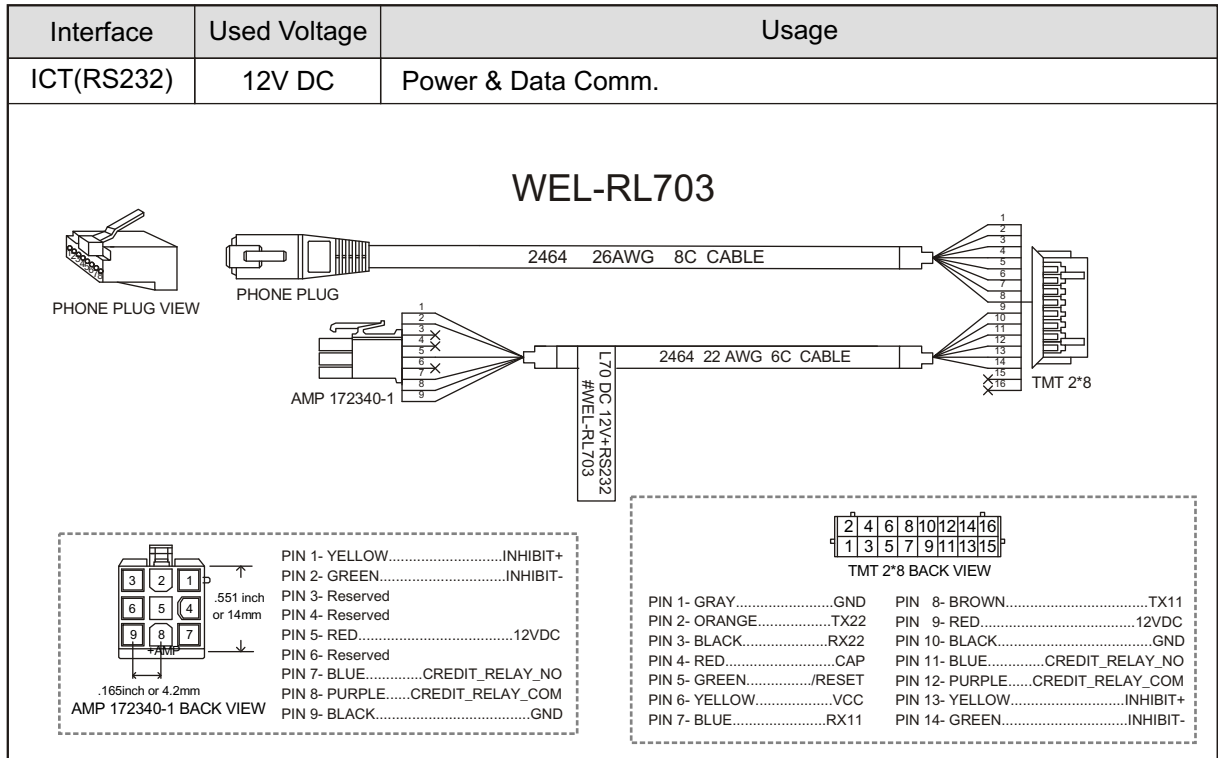

Figure 13.

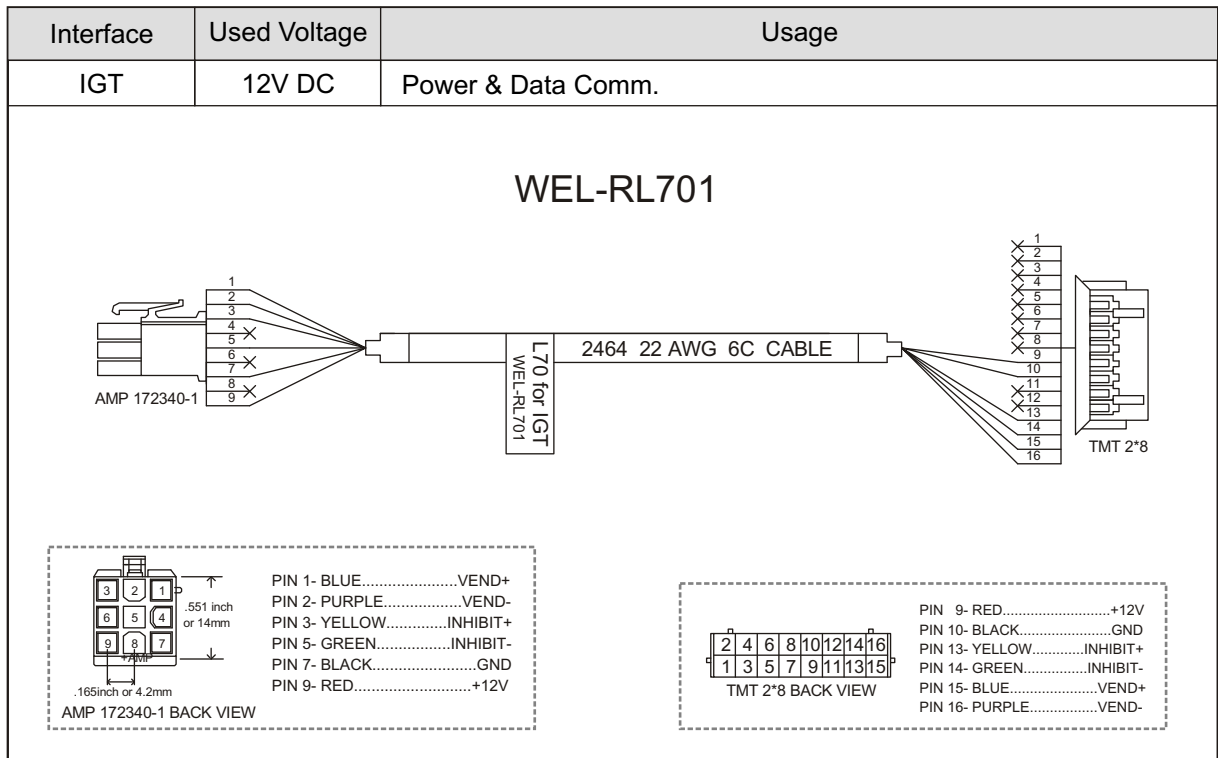

Figure 14.

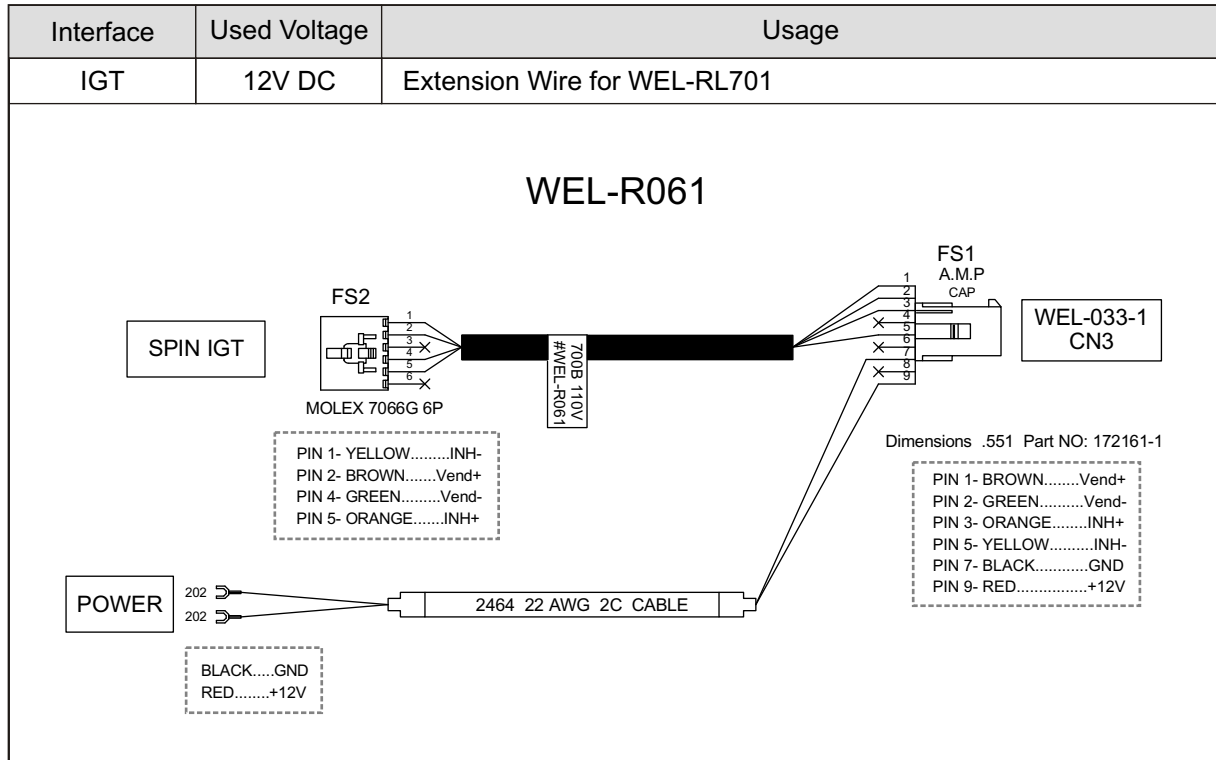

Figure 15.

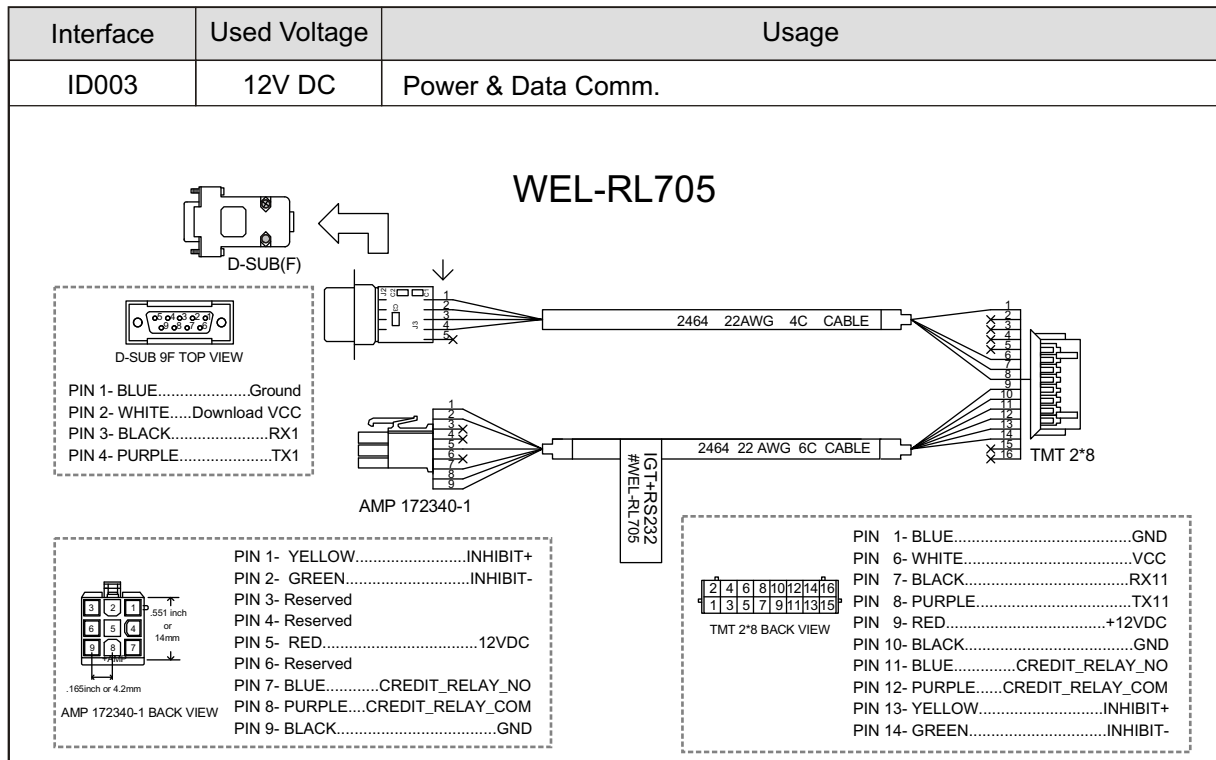

Figure 16.

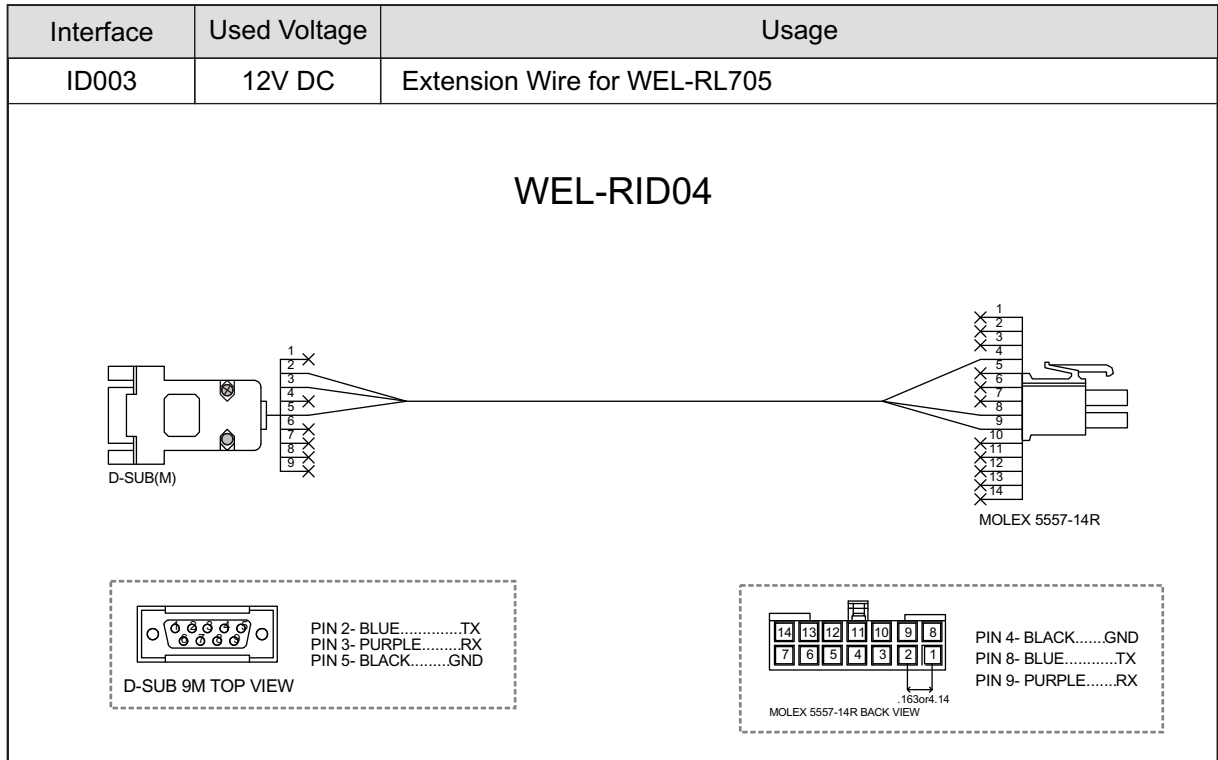

Figure 17.

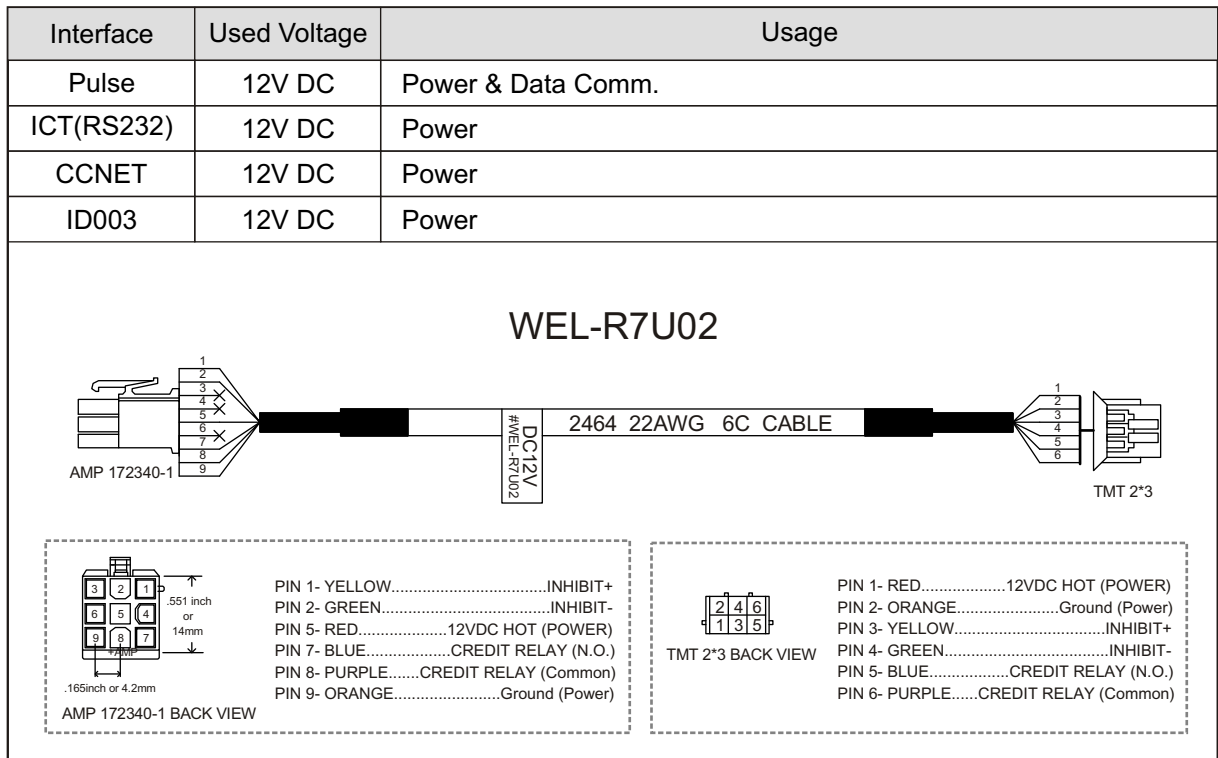

Figure 18.

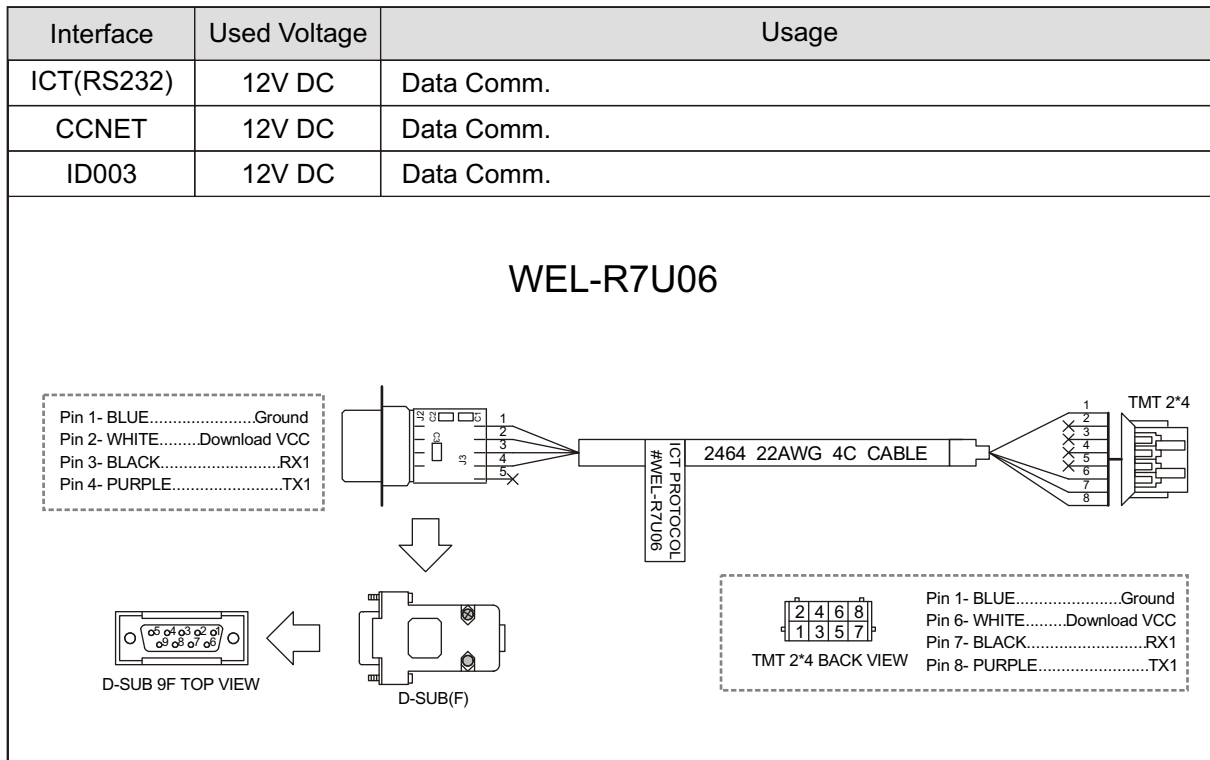

Figure 19.

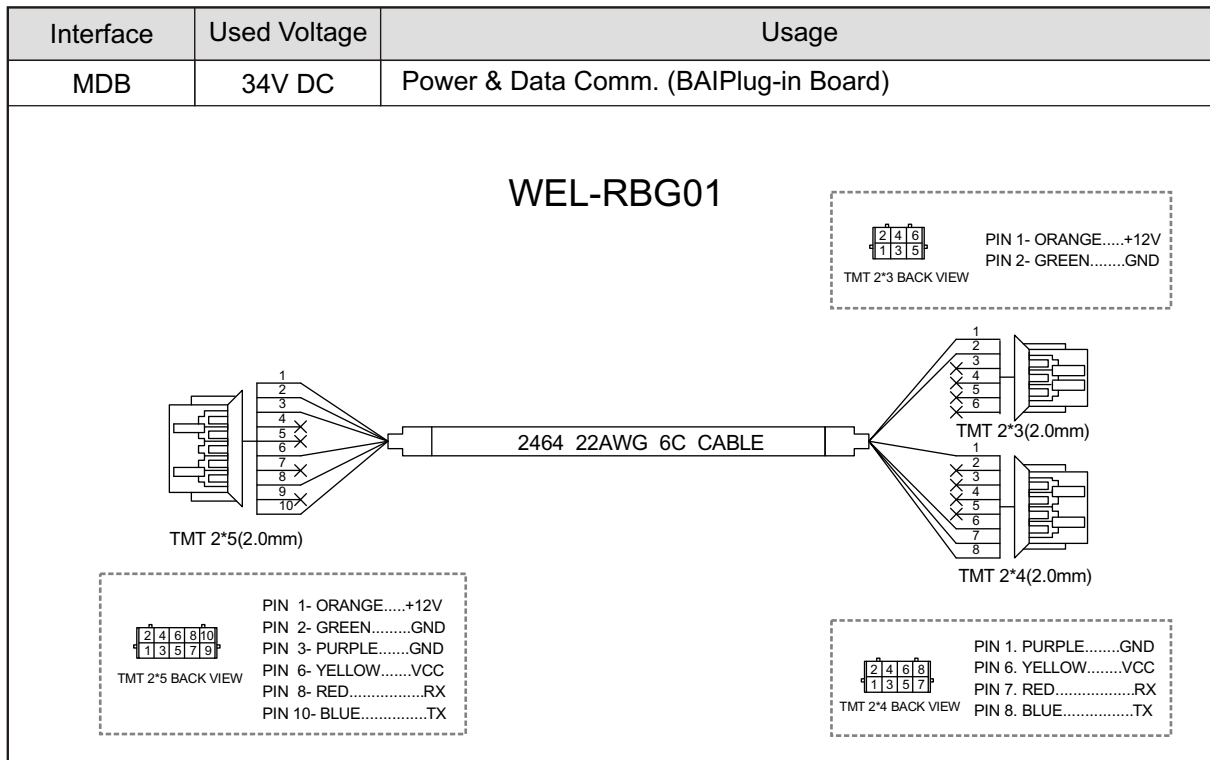

Figure 20.

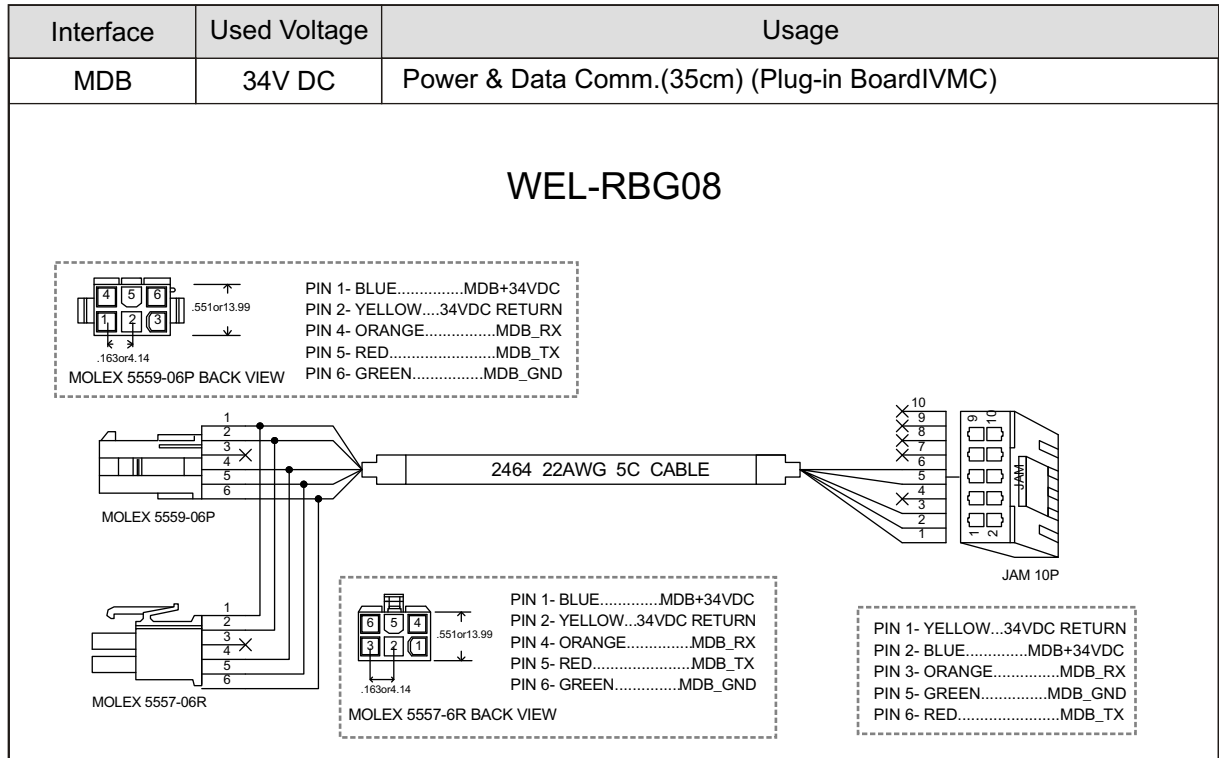

Figure 21.

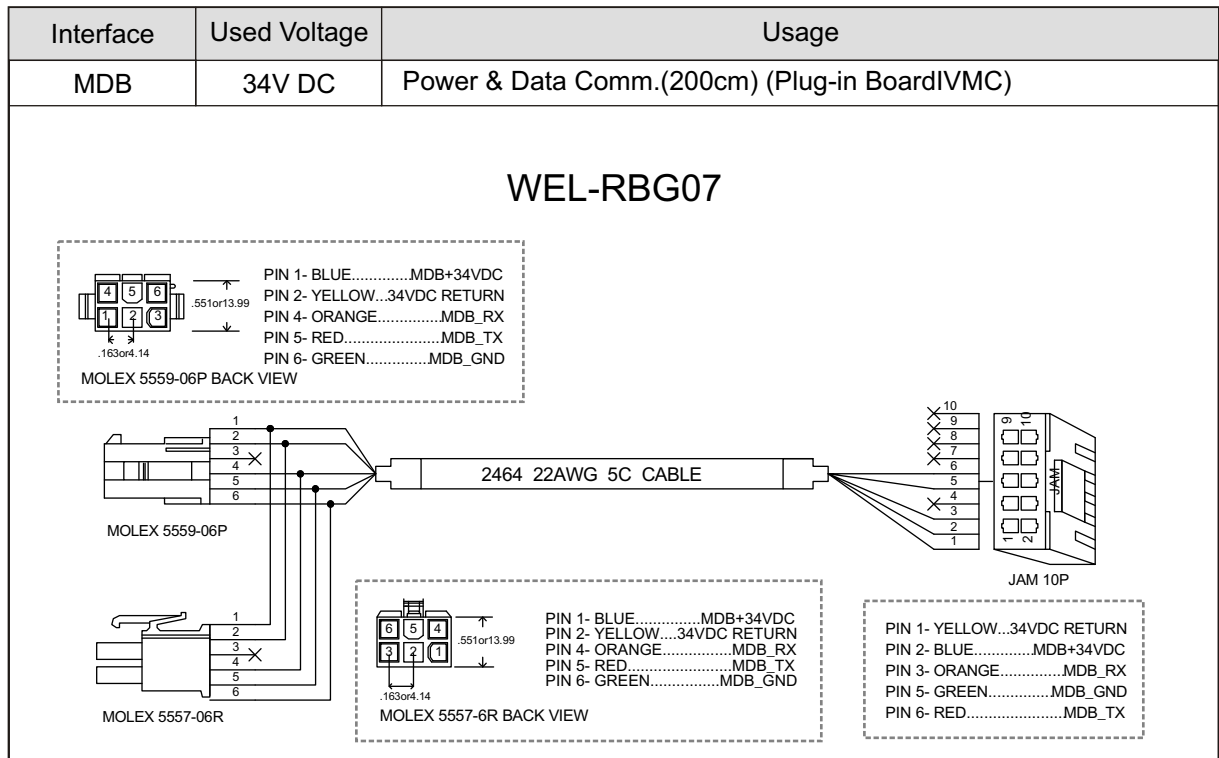

Figure 22.

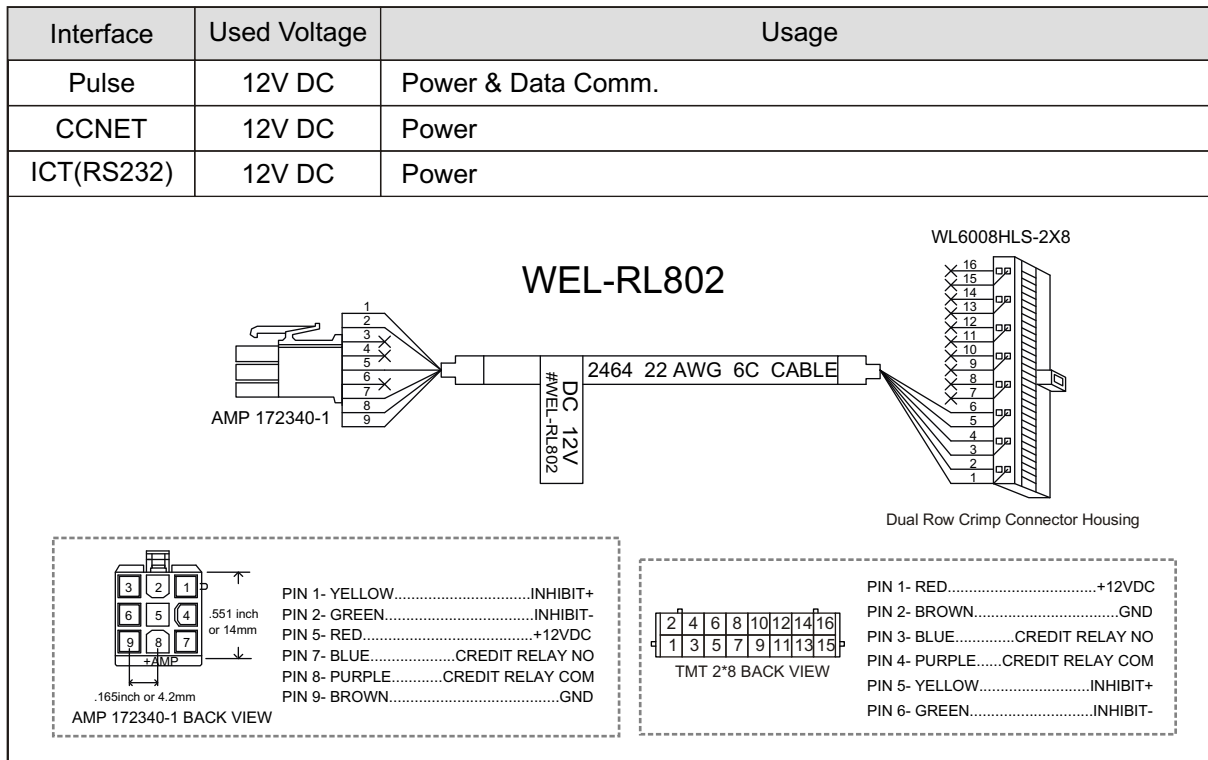

Figure 23.

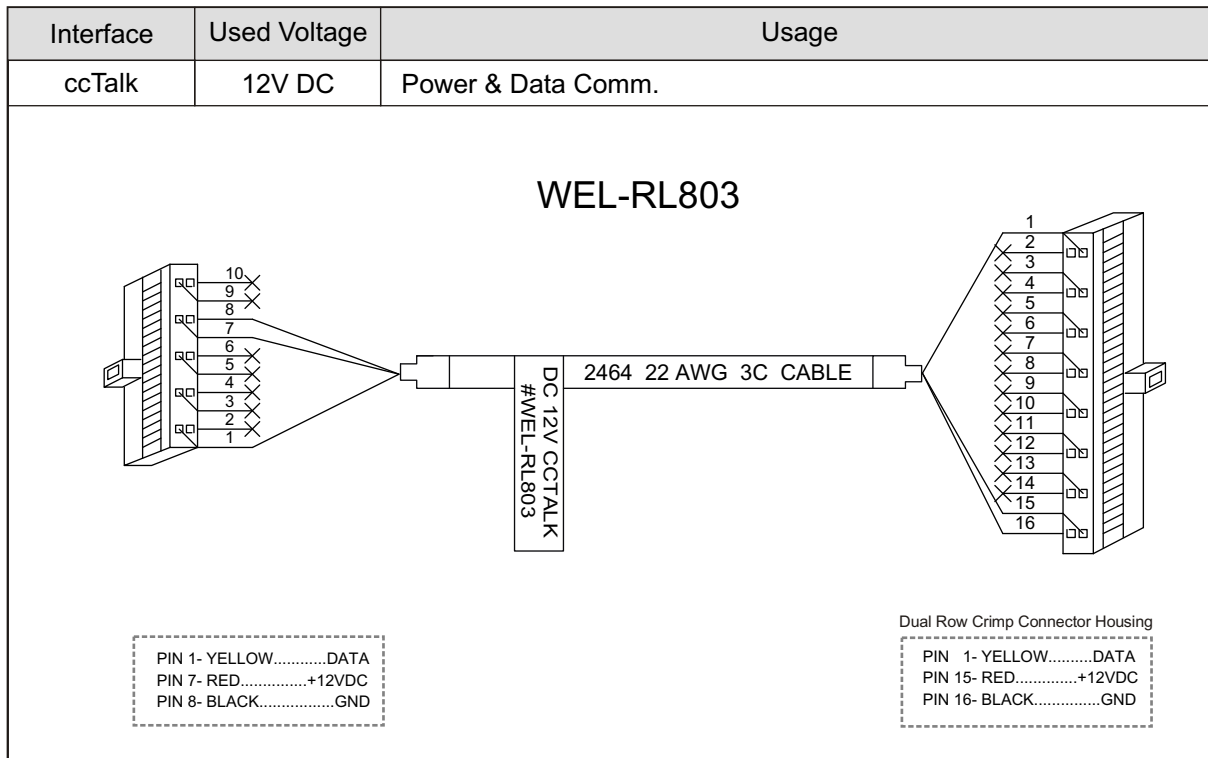

Figure 24.

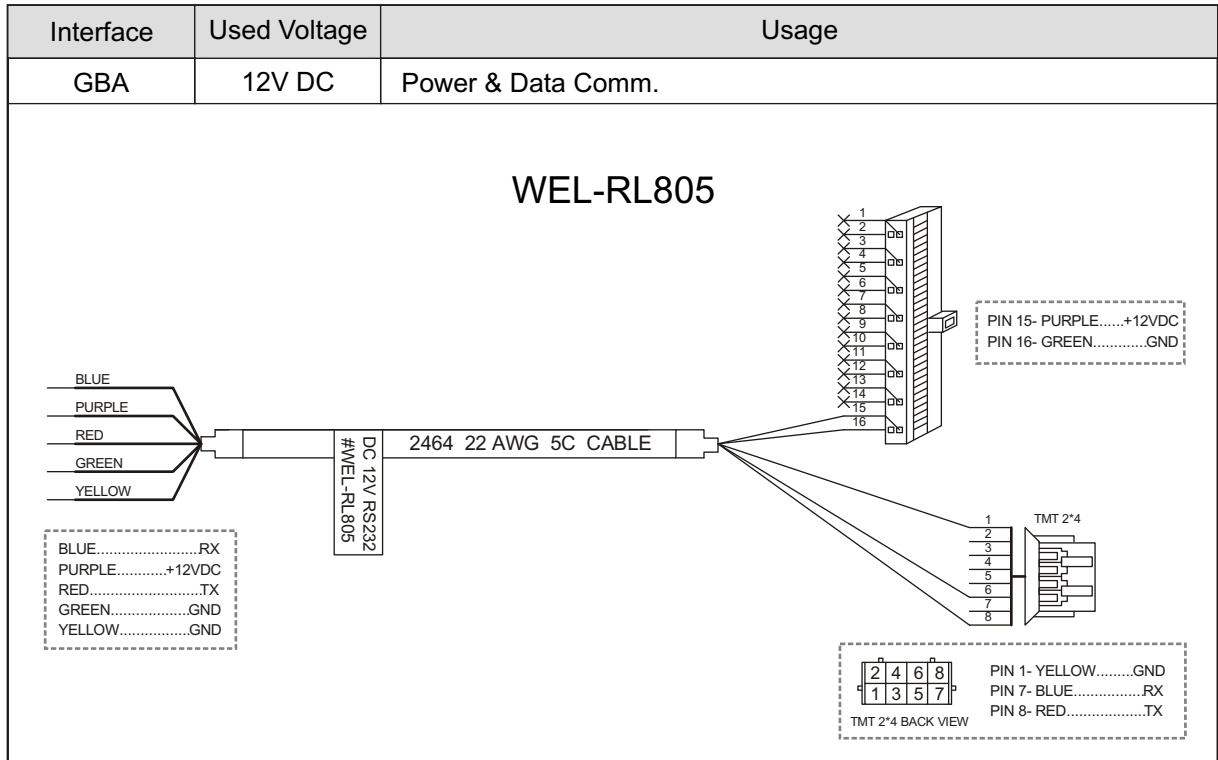

Figure 25.

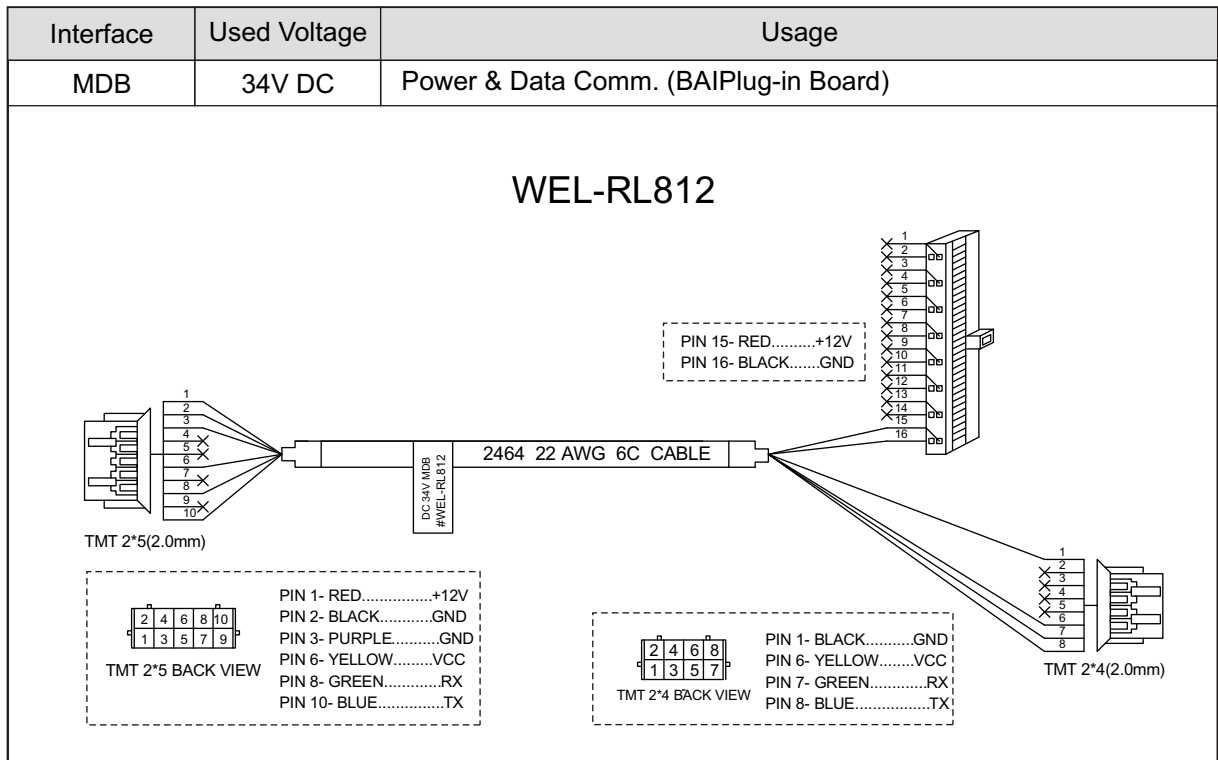

Figure 26.

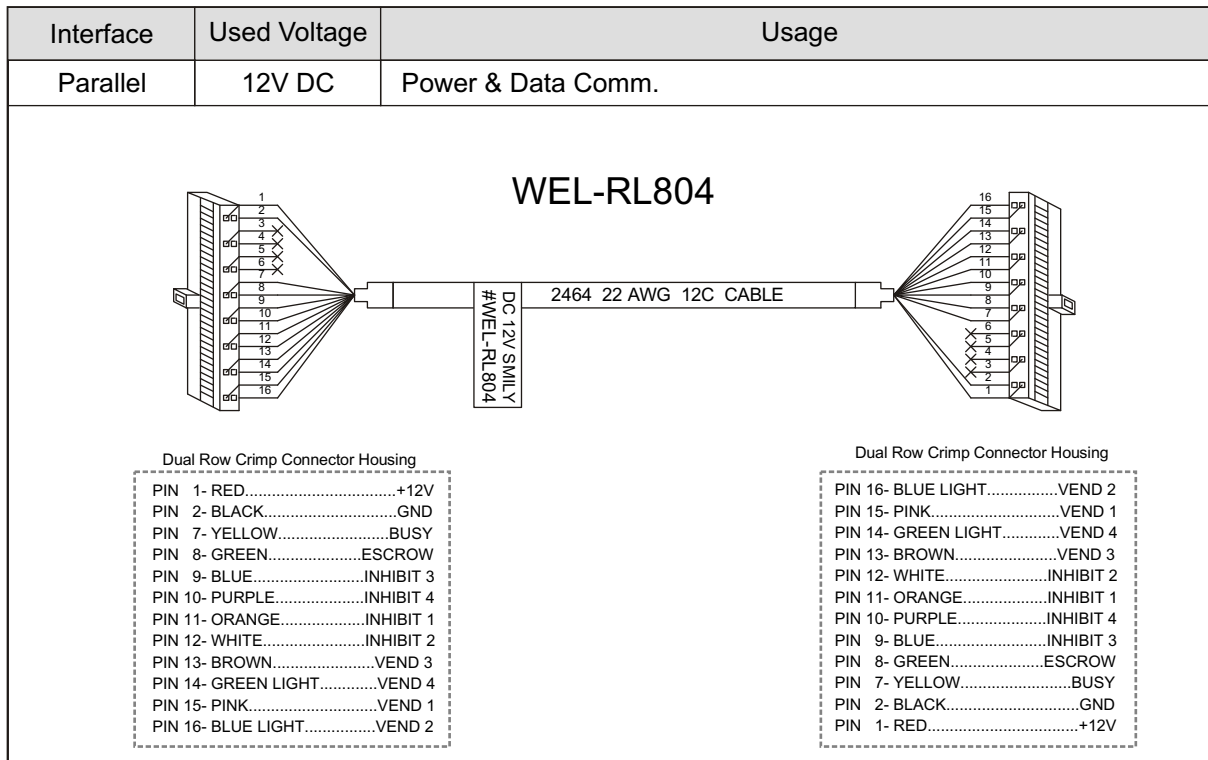
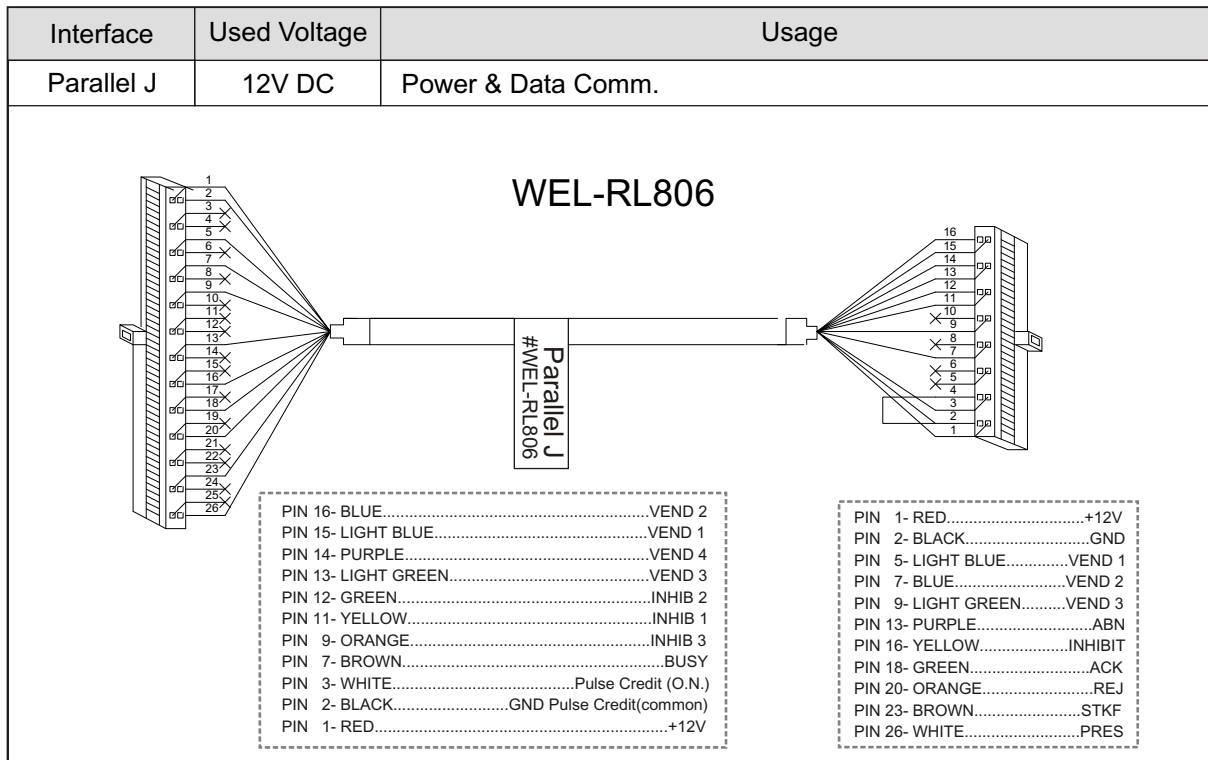

Figure 27.



1-5. Bezel Styles :

L70(#)
(67mm)
Part Number: 3RBA-FAC30000

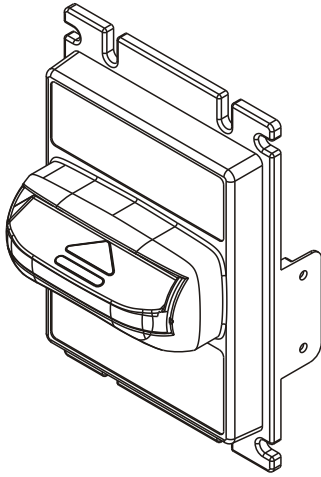

Figure 28.

L70(#)
(71mm)
Part Number: 3RBA-FAC31000

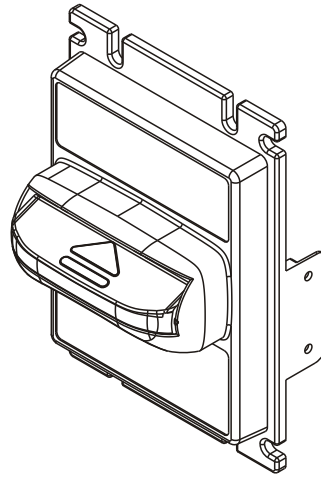

Figure 29.

L83(#)
Part Number: 3RBA-FAC35001

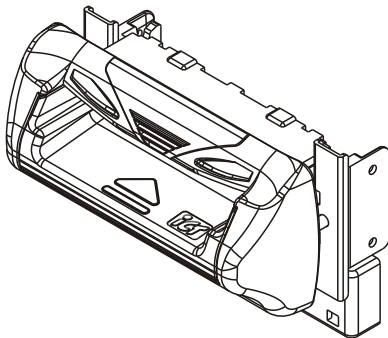

Figure 30.

L77(#)
Part Number: 3RBA-FAC44000

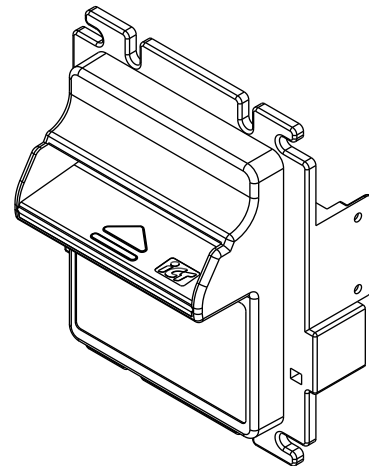

Figure 31.

Bezel E

Part Number: 3RBA-FAC46000

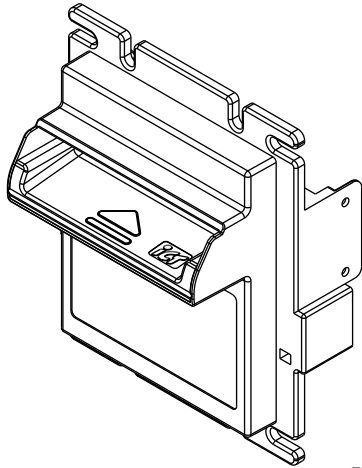

Figure 32.

Bezel F

Part Number: 3RBA-FAC47000

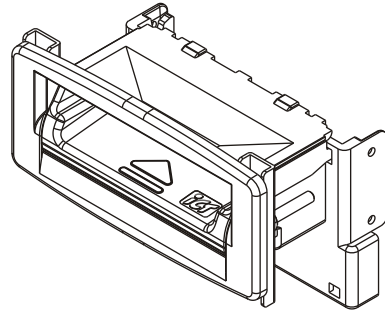

Figure 33.

PL77

Part Number: 3RBA-FAC45000

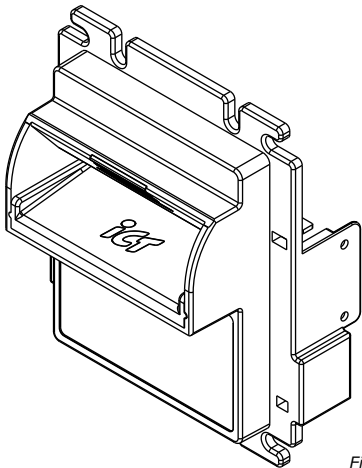

Figure 34.

2. Installation :

2-1. Download Firmware

2-1-1. PC → BA

Step 1 :
Connection

Figure 35.

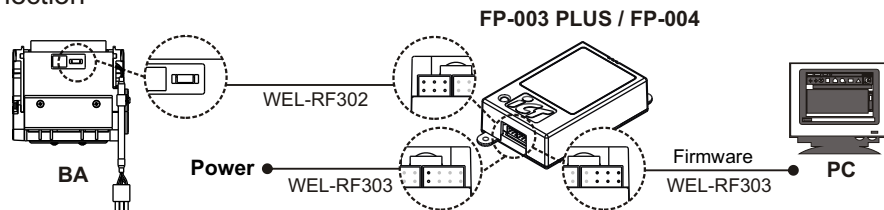

Turn on Bill Acceptor after connection.

Step 2 :
Launch software FP-003 PLUS/ FP-004. Download FP-003 PLUS/ FP-004 from <http://www.ictgroup.com.tw/> → support

Step 3 :
FP-003 PLUS/ FP-004 setting. Port **COM1 OR COM2**
The com port setting varies according to the connection on PC.

<FP-003 PLUS>

Step 4 : Retrieve the firmware path.



Figure 36.

Step 5 : Download firmware to target.

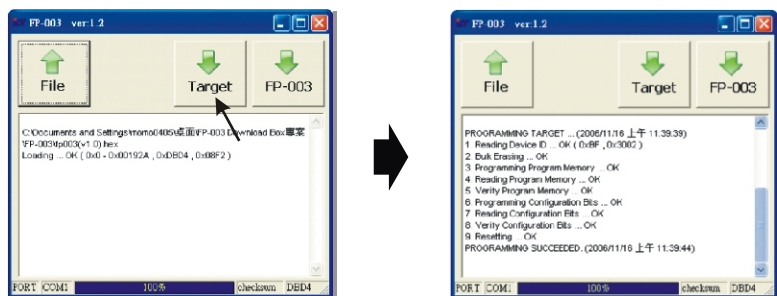

Figure 37.

Step 6 : Firmware is saved in BA now.

<FP-004>

Step 4 :

Choose Bill Acceptor, then choose L Series.

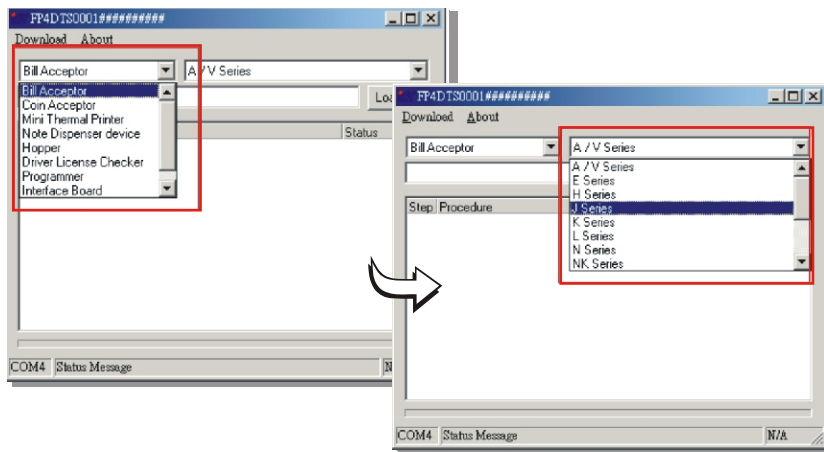

Figure 38.

Step 5 :

Choose the firmware (mhx/ hex file) to download it.

Step 6 :

Click on [To Device] to start downloading, the related messages about program codes will be shown on the window block.

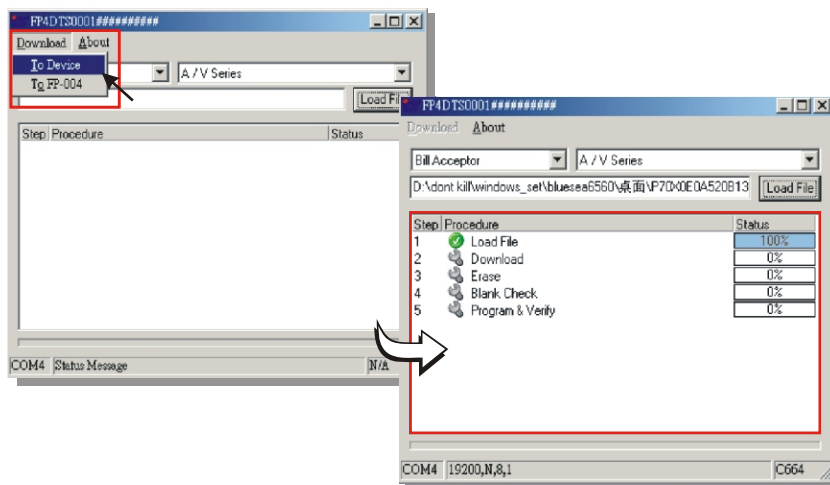

Figure 39.

Step 7:

Firmware is saved in BA now.

2-1-2. PC → FP-003 PLUS/ FP-004 → BA

PC → FP-003 PLUS/ FP-004

Step 1 :
Connection

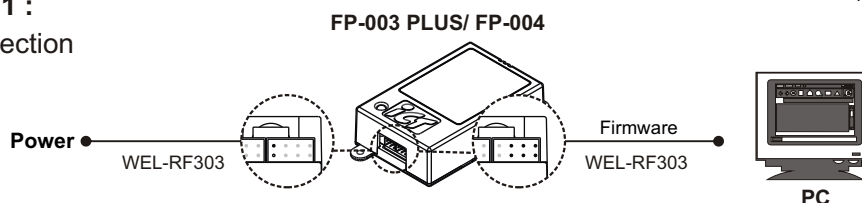

Figure 40.

Turn on FP-003 PLUS/ FP-004 after connection.

Step 2 :

Launch software FP-003 PLUS/ FP-004. Download FP-003 PLUS/ FP-004 from <http://www.ictgroup.com.tw/> → support

Step 3 :

FP-003 PLUS/ FP-004 setting. Port **COM1 OR COM2**

The com port setting varies according to the connection on PC.

<FP-003 PLUS>

Step 4 : Retrieve the firmware path.

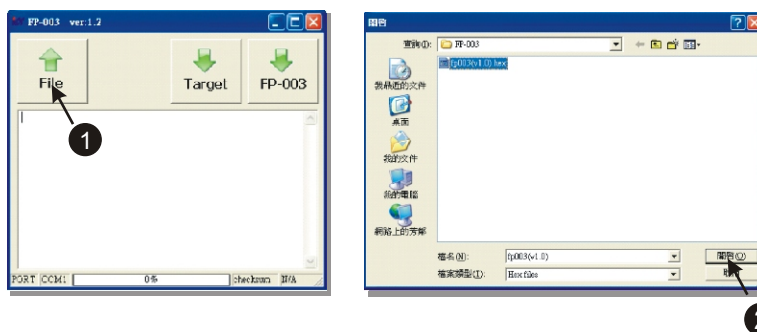

Figure 41.

Step 5 : Download firmware to target.

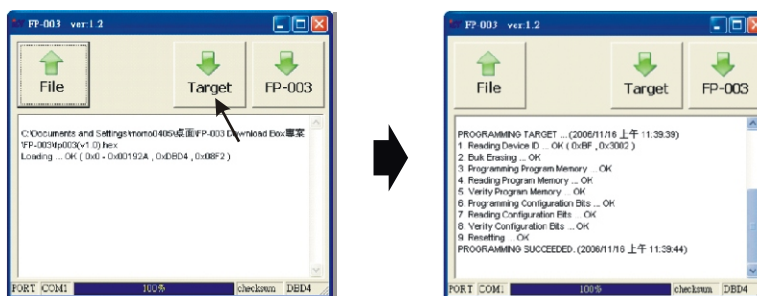

Figure 42.

Step 6 : Firmware is saved in FP-003 PLUS now.

<FP-004>

Step 4 :

Choose Bill Acceptor, then choose L Series.

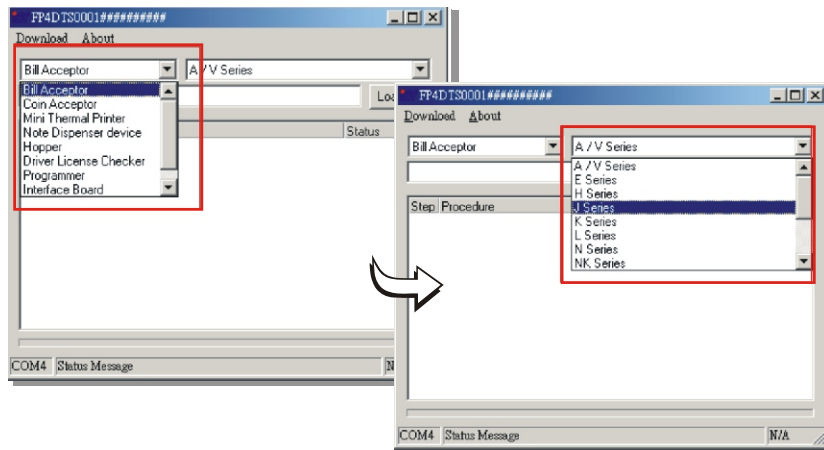

Figure 43.

Step 5 :

Choose the firmware (mxh/ hex file) to download it.

Step 6 :

Click on **[To Device]** to start downloading, the related messages about program codes will be shown on the window block.

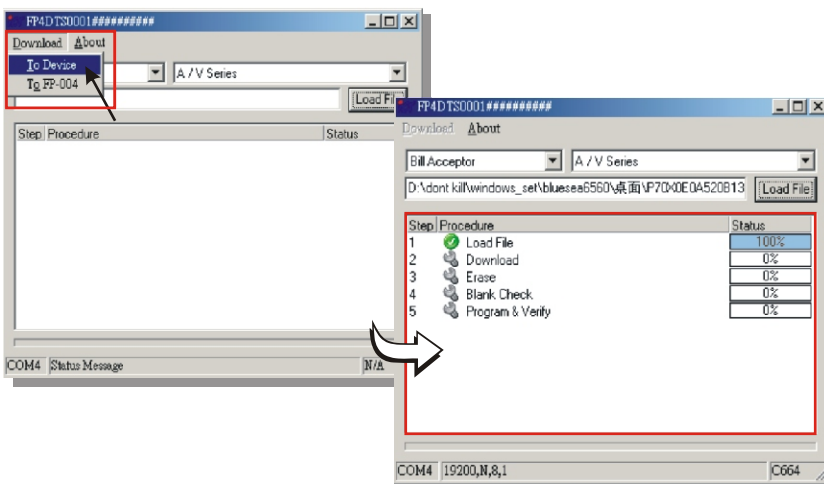

Figure 44.

Step 7:

Firmware is saved in FP-004 now.

FP-003 PLUS/ FP-004 → BA

Step 1 : Connection

Figure 45.

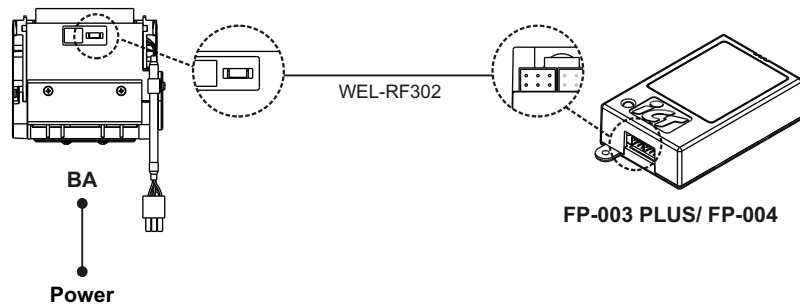

Step 2 : Start downloading a new firmware to BA.

FP-003 PLUS/ FP-004 to BA

Step 1: Press and hold the button for at least 3 seconds, and wait until the faceplate LED turns to orange (FP-003 PLUS) or purple (FP-004).

Step 2: The faceplate LED will flash faster and faster as it's approaching the end of download progress.

Step 3: After downloading, the faceplate LED will indicate "Green" as successful, or "Red" as failed downloading in 3 seconds.

Figure 46.

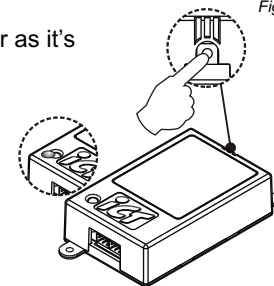

FP-003 PLUS/ FP-004

Note: As downloading the firmware to BA in this mode, PC Tool shows download progress automatically.

Step 3 : Indirect downloading finish.

2-2. Auto Testing Tool

For testing, please download auto testing tool on www.ictgroup.com.tw, and connect FP-001 to Bill Acceptor and PC.

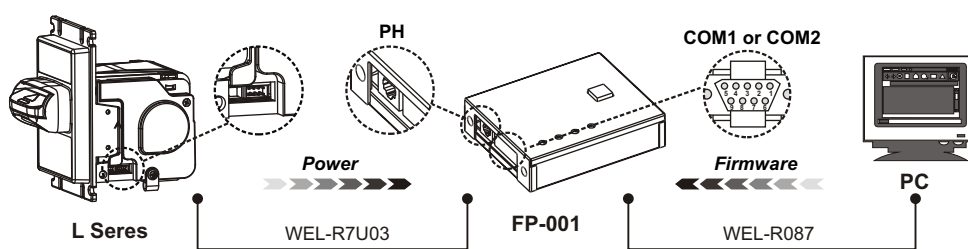

Figure 47.

Turn on Bill Acceptor after connection.

Step1. Start the program.

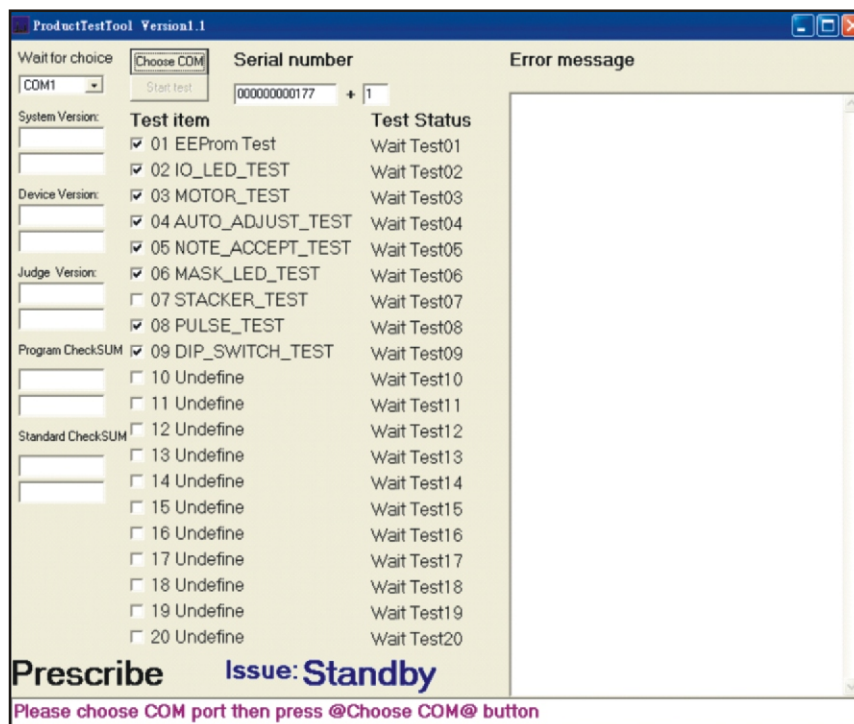

Figure 48.

Step 2. Choose “COM” port and click “COM”.

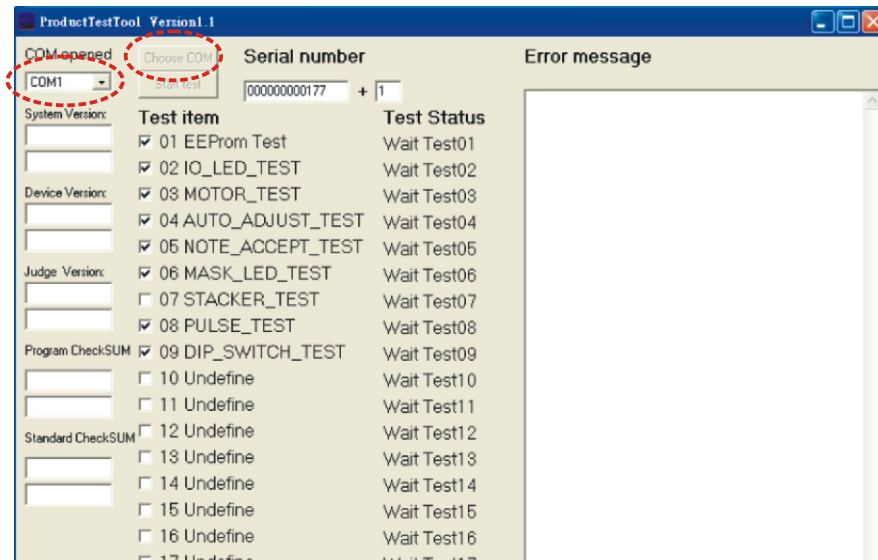

Figure 49.

Step 3. Restart BA, confirm “Software Version” and “Check SUM”, and then click “Start test”.

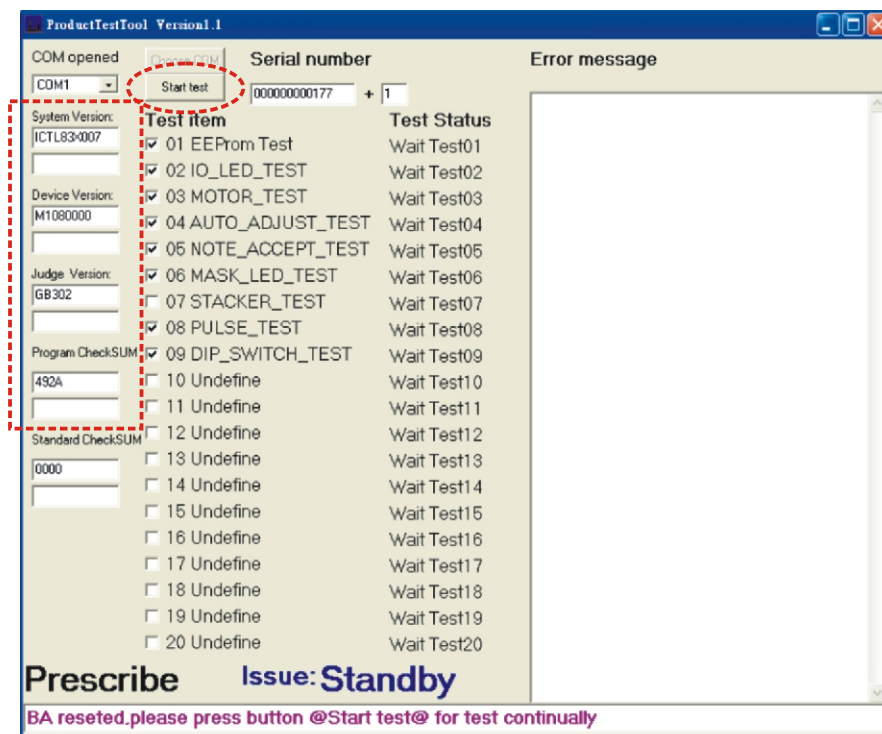

Figure 50.

Step 4. Program starts to test “Test item” automatically.
The error status will be shown in the “Error message” block.

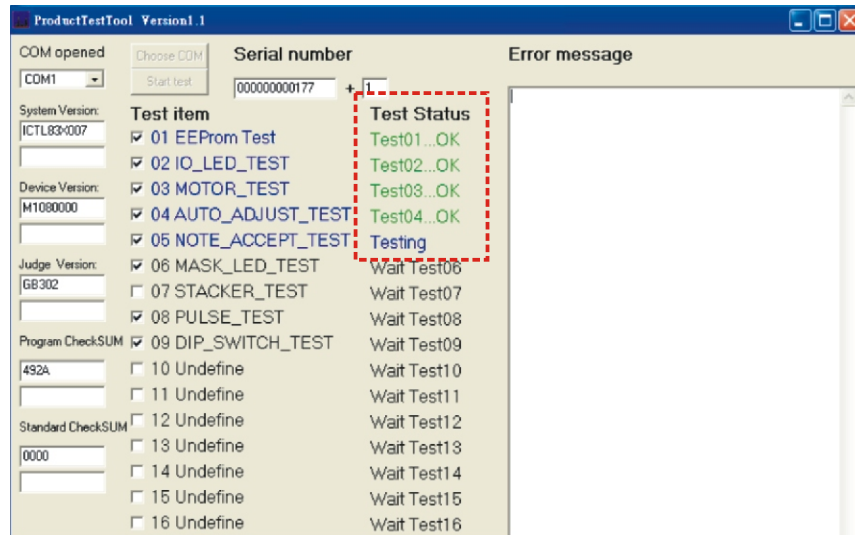

Figure 51.

Step 5. Insert a random note to test the input sensor.

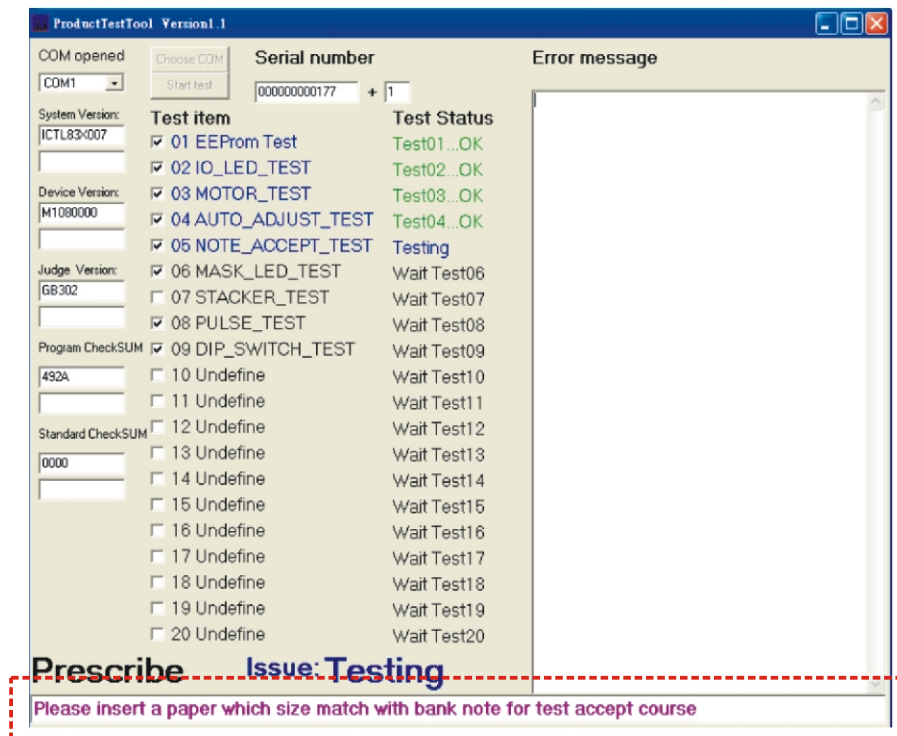

Figure 52.

Step 6. Click “OK” if the mask LED flashes red, green, and blue by rotation.
 Click “NG” if the mask LED does not flash red, green, and blue by rotation.

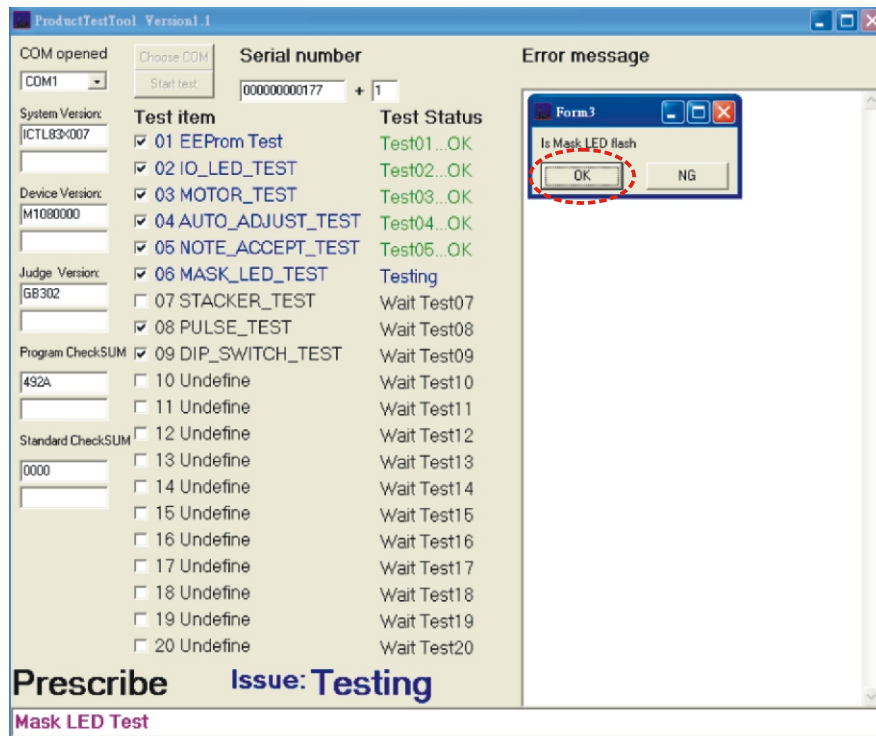

Figure 53.

Step 7. Click “OK” if pulse has been sending and shown on the screen of BA tester.
Click “NG” if pulse has not been sending and shown on the screen of BA tester.

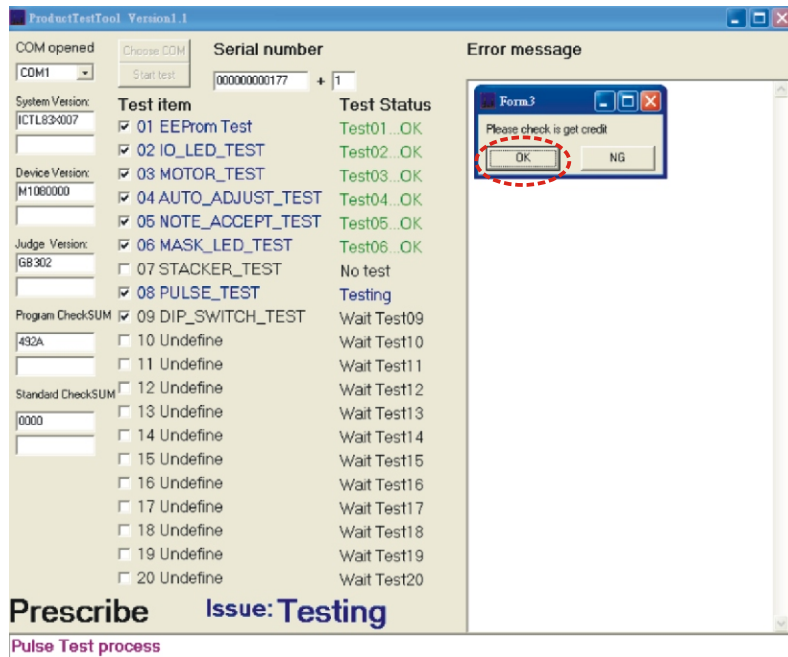

Figure 54.

Step 8. Turn switch “ON” to adjust DIP-SWITCH by turns, make sure other three switches are “OFF” in the meantime.

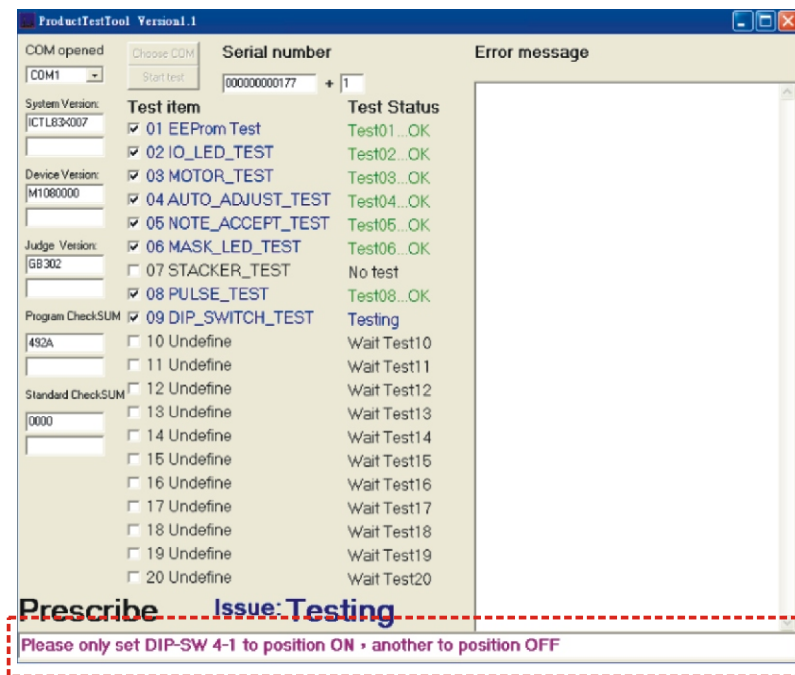

Figure 55.

- Test Result_Error machine :**
1. Testing issue block shows NG.
 2. DIP-SW adjusting error.
 3. Pulse function is failed.

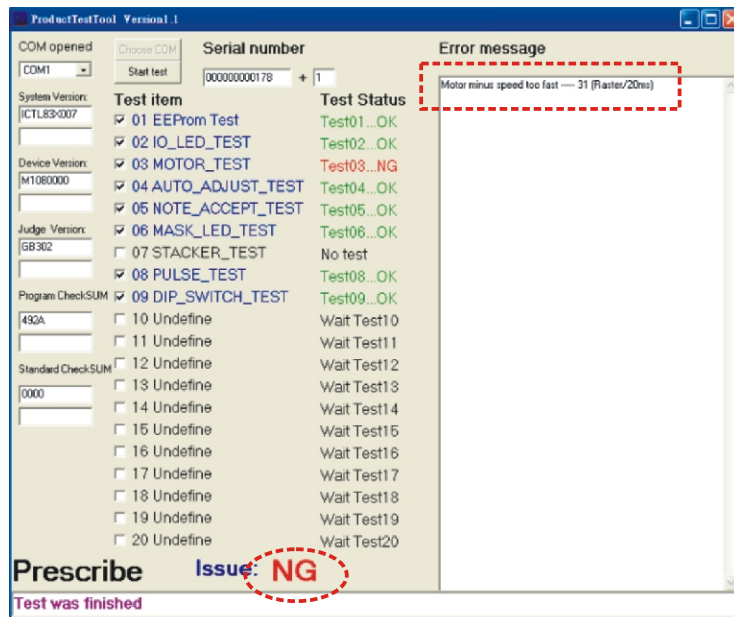

Figure 56.

- Test Result_Normal machine :**
1. Testing issue block shows OK.
 2. DIP-SW adjustments go smoothly.
 3. Pulse function is normal.

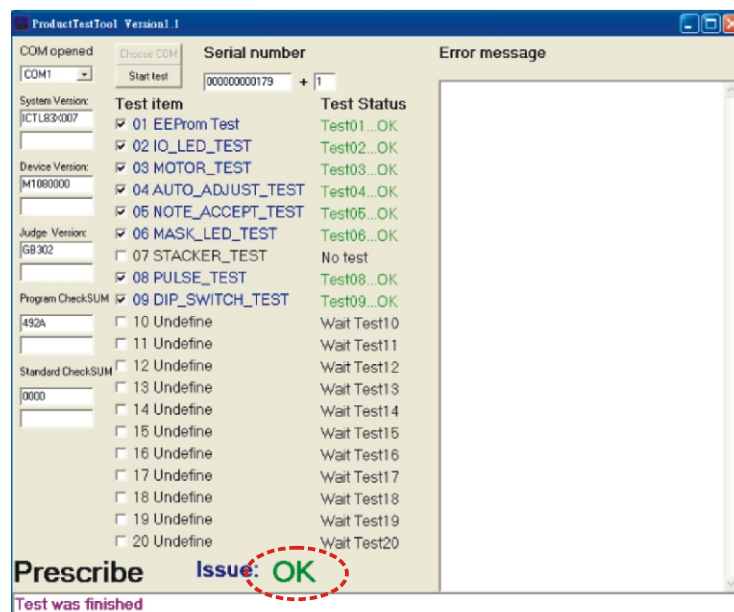
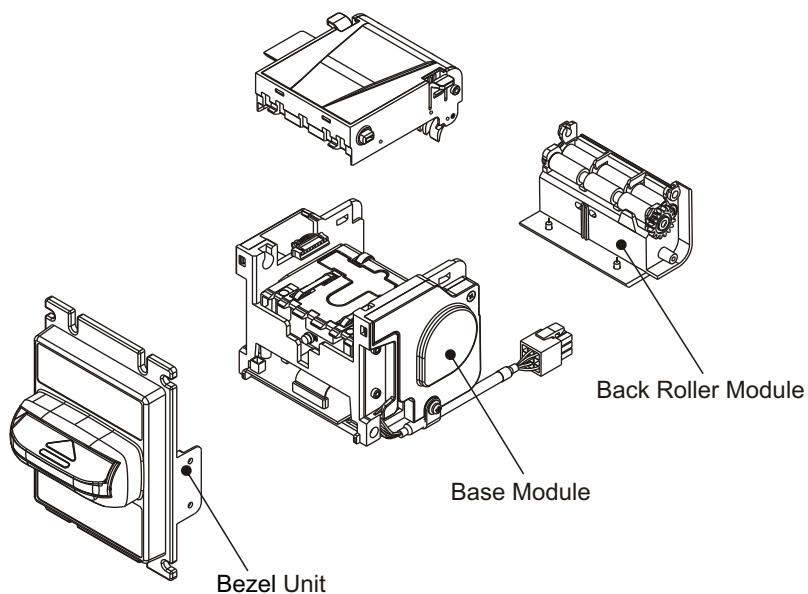

Figure 57.

2-3. Component Names

2-3-1. Stackerless Bill Acceptor

Figure 58.



2-3-2. Bill Acceptor with Stacker

Figure 59.

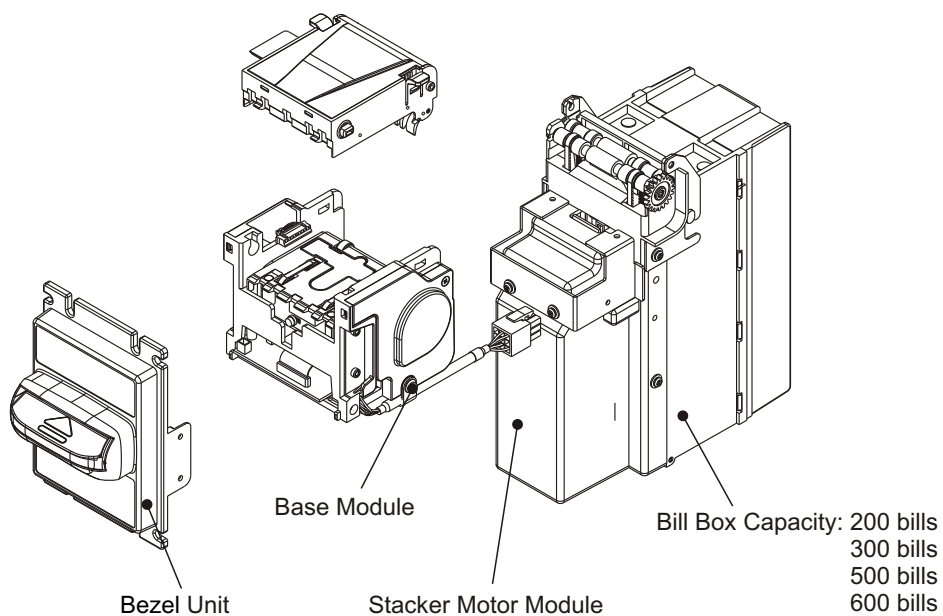

2-4. Assembling Procedure

2-4-1. Assembling Removing Procedure

1. Remove bezel unit.

Open upper base module and pull bezel unit out.

L70(#)

Figure 60.

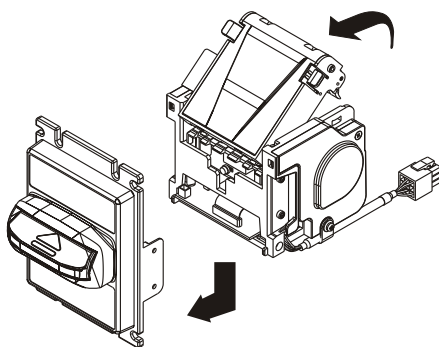

L83(#)

Figure 61.

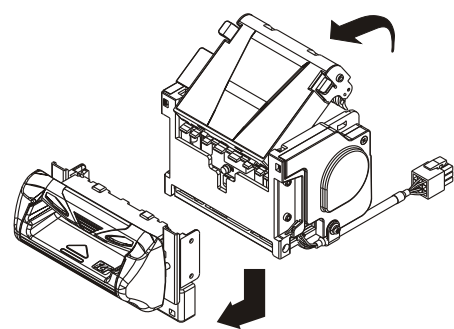

L77(#)

Figure 62.

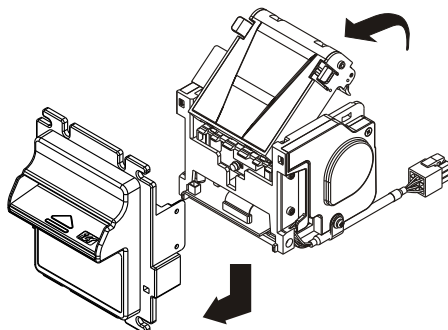

PL77

Figure 63.

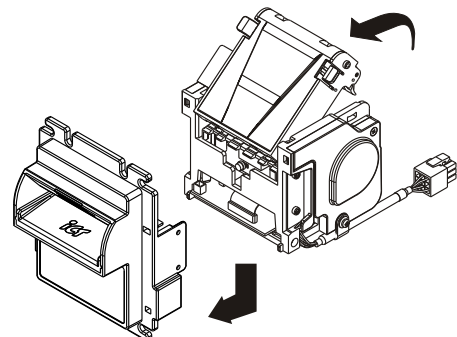

2. Open upper base module, push all the way down and lift it up. Unplug the cloning kit after removing upper base module.

Figure 64.

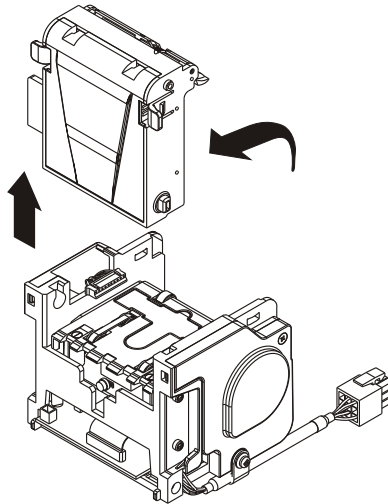

3. Remove the upper base cover plate.

Figure 65.

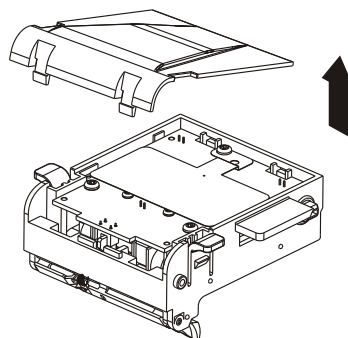

4. Loosen three screws and take the conductive piece and sensor CPU board out.

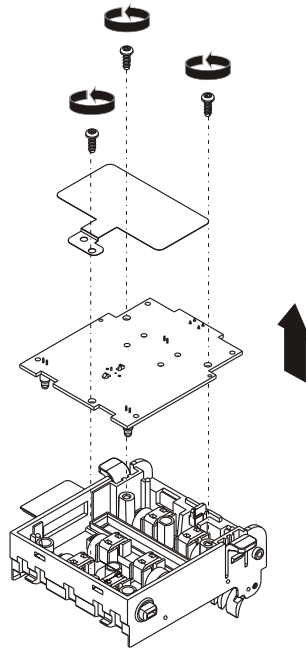

Figure 66.

5. Remove the idler hooks, springs, and rollers.

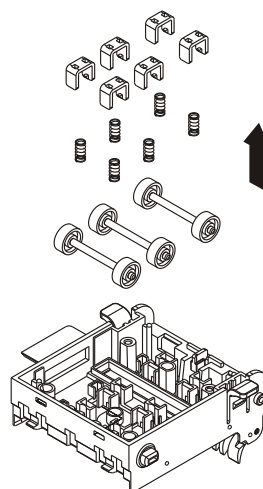
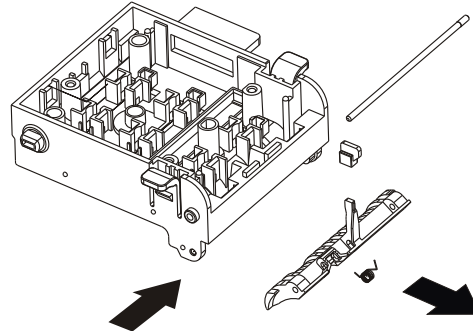

Figure 67.

6. Take security shaft out and then remove security tooth and security tooth spring.

Figure 68.



7. Loosen two screws on the roller mount; revolve the roller mount and pull it out.

Figure 69.

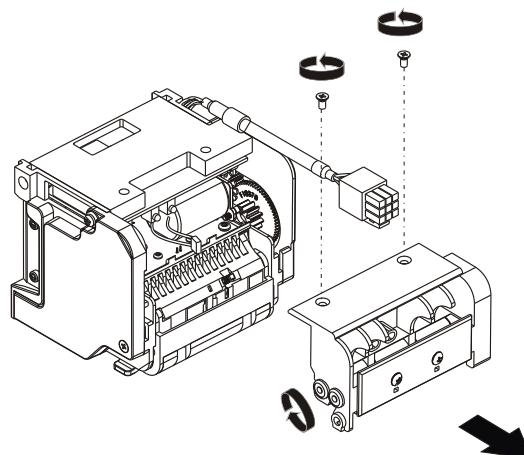

8. Loosen two screws on right gear cover plate; remove power cable, right gear cover plate, and two gears.

Figure 70.

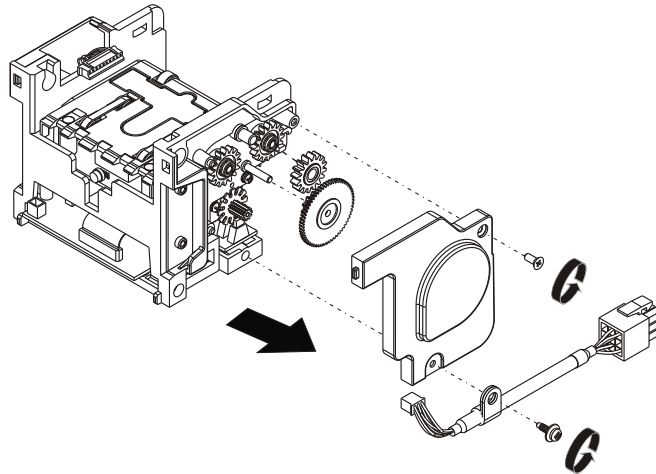

9. Loosen two screws on left gear cover plate; remove left cover plate and connect wiring.

Figure 71.

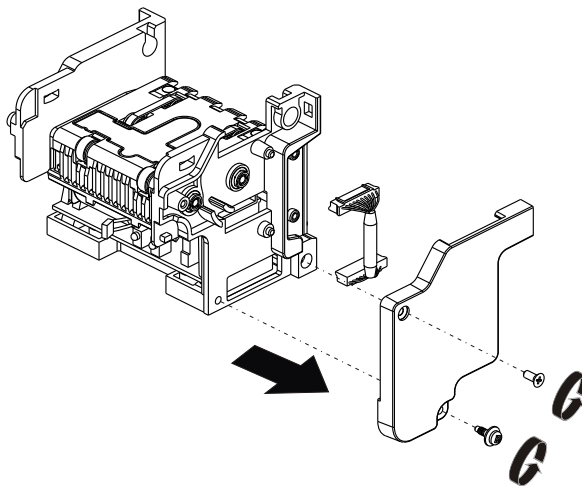

10. Open lower base cover and pull it out.

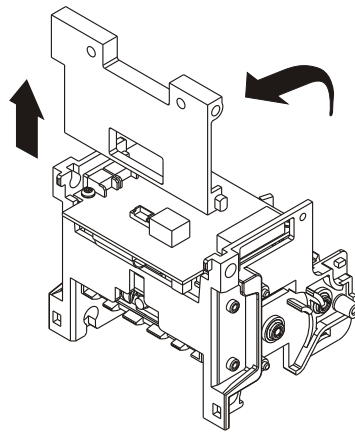

Figure 72.

11. Loosen three screws on CPU board; remove CPU board; unplug motor wiring and cloning kit.

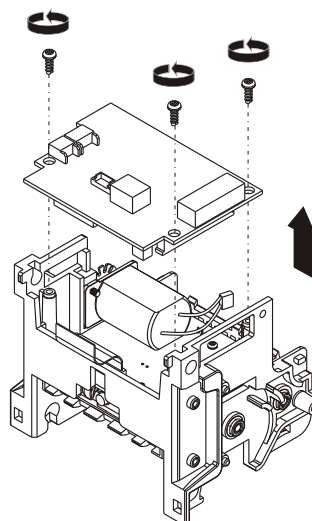

Figure 73.

12. Loosen two screws on motor, and then remove motor module.

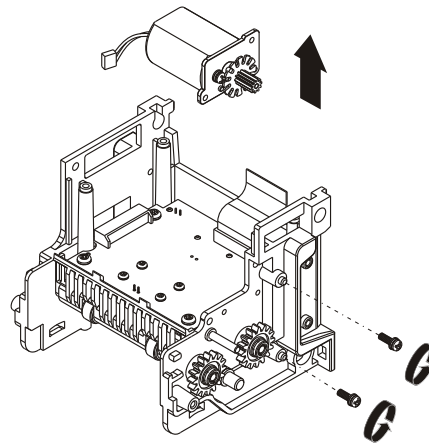

Figure 74.

13. Loosen four screws on LED PCB board, and then remove LED PCB board.

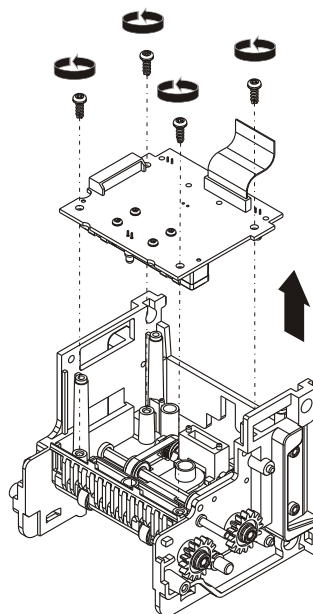

Figure 75.

14. Remove belt roller fixed stand, belt roller, and belt roller axle.

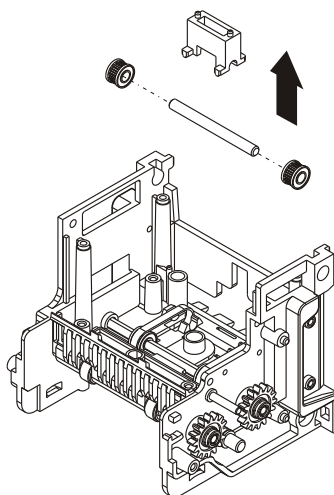

Figure 76.

15. Pull out plastic retaining ring, and then remove belt rollers, belts, belt roller axles, and gears.

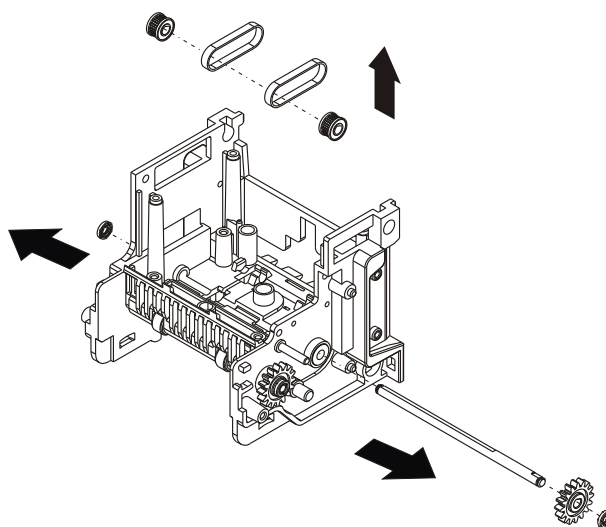
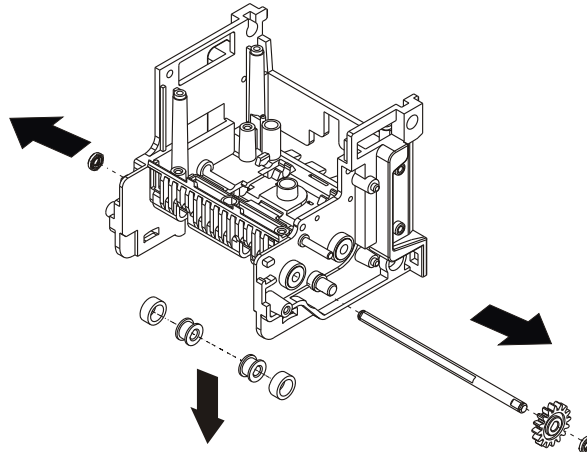

Figure 77.

16. Pull out plastic retaining ring, and then remove rubber belt rollers, belt roller axles, and gears.

Figure 78.



17. Remove four axle sleeves.

Figure 79.

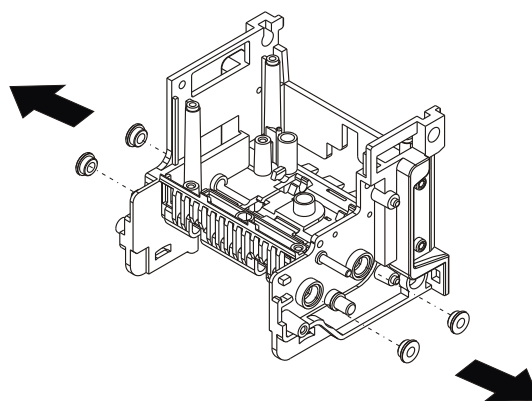

18. Pull out motor raster, loosen two screws on it, and remove motor fixed stand.

Figure 80.

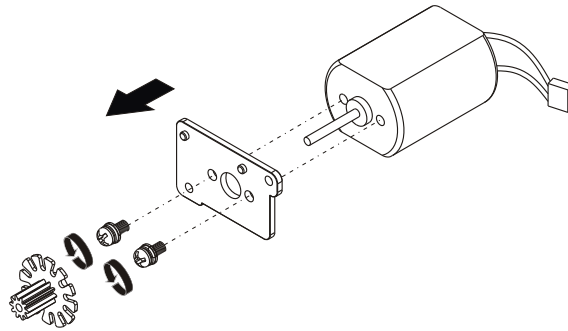

19. Loosen two screws on reflector, and then remove it.

Figure 81.

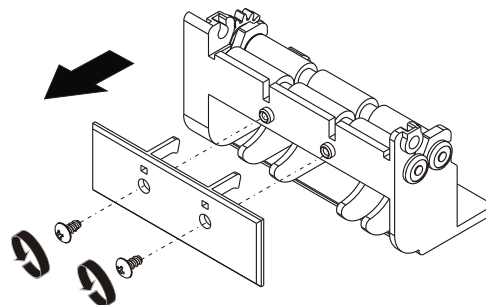

20. Pull out gears, remove axle sleeves on two sides, and then remove rubber rollers type D.

Figure 82.

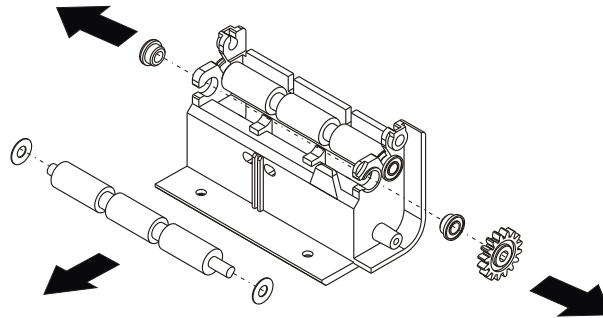

21. Remove other rubber roller axle sleeves and rubber rollers.

Figure 83.

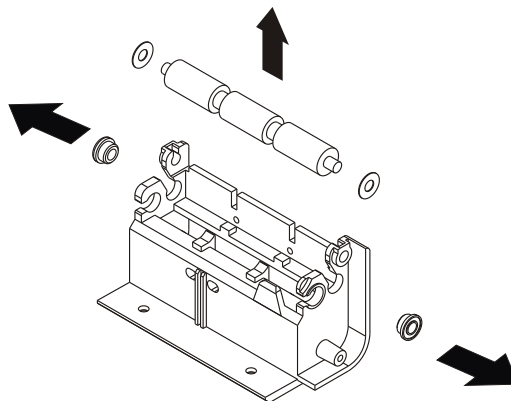

22. Loosen two screws, and then remove the anti-fishing iron plate.
<L83(#) only>.

Figure 84.

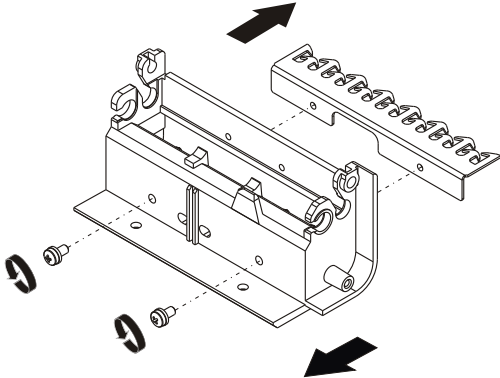

2-4-2. L70(#) / L83(#) Stacker Motor Module and Bill Box Removing Procedure.

1. Remove the bill box.

Figure 85.

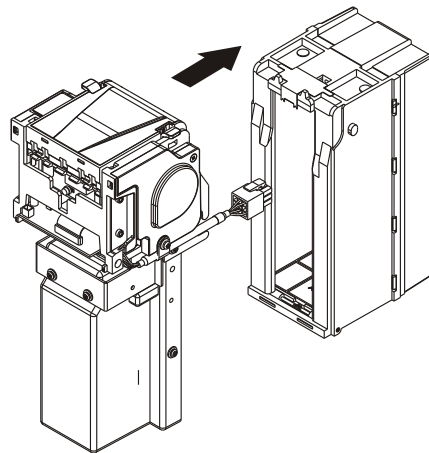

2. Remove both left and right cover plates.

Figure 86.

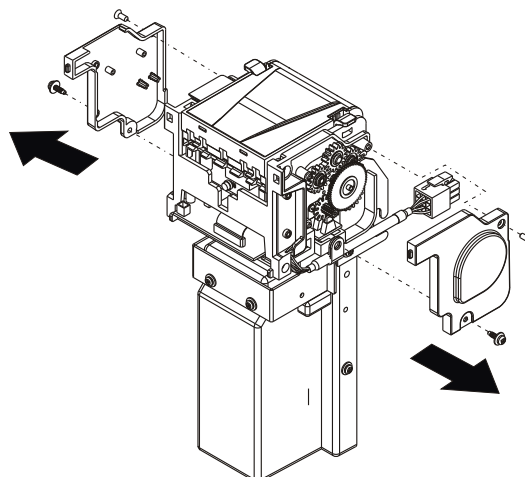

3. Loosen two screws, revolve stacker motor module and then pull it out.

Figure 87.

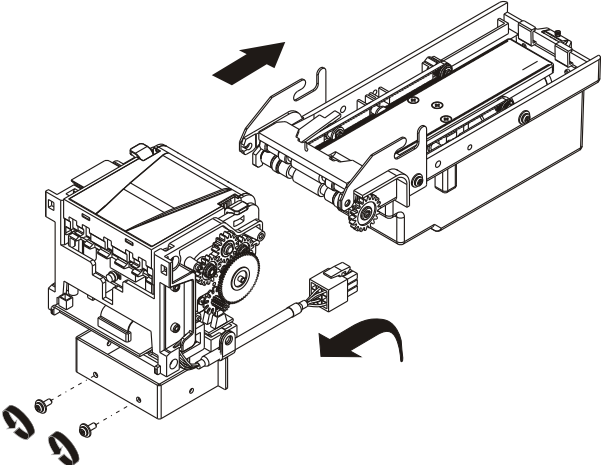

3. Operation :

3-1. Operation Flowchart

Figure 88.

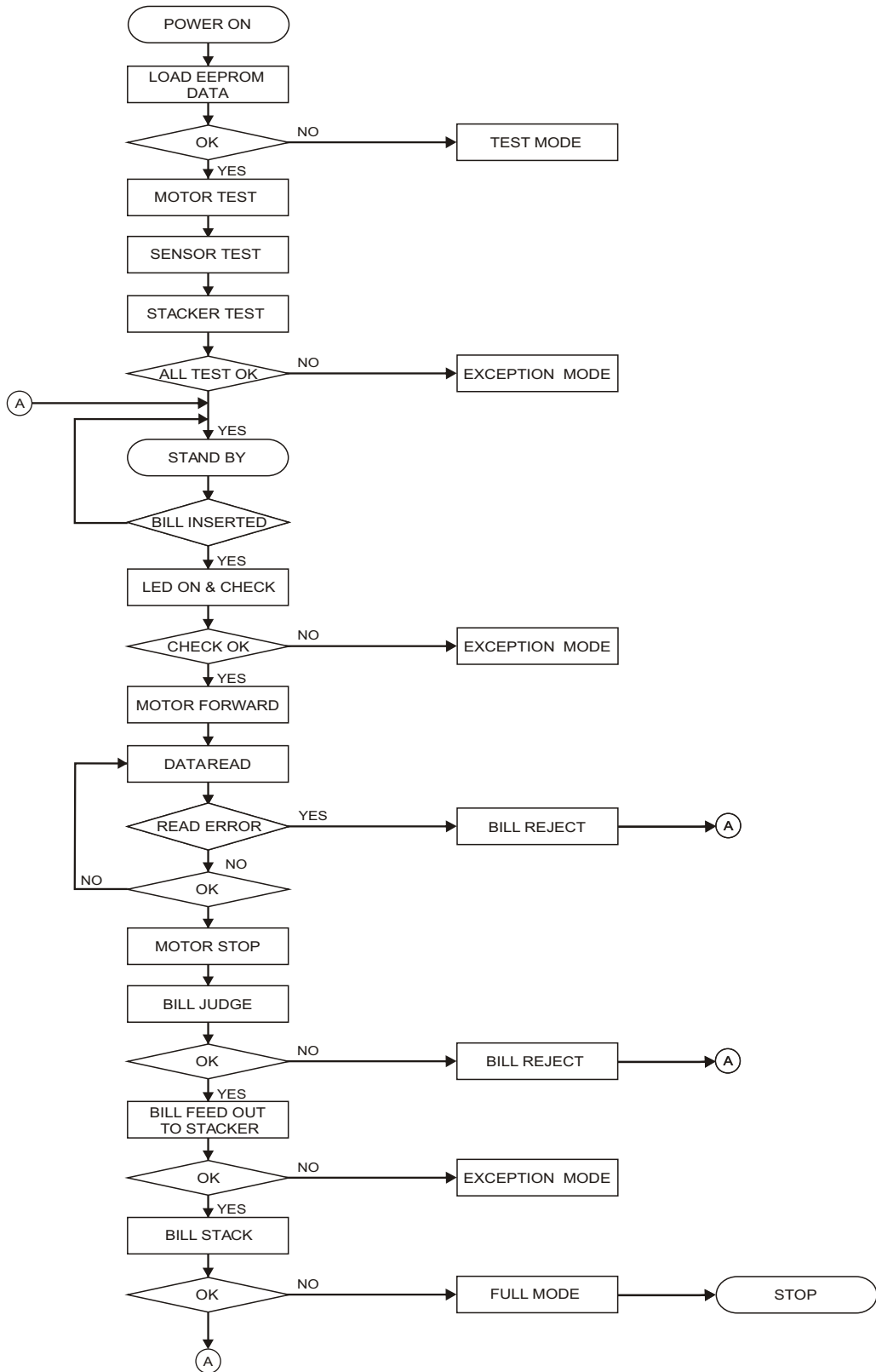

3-2. I/O Circuits

Pulse Interface.

Figure 89.

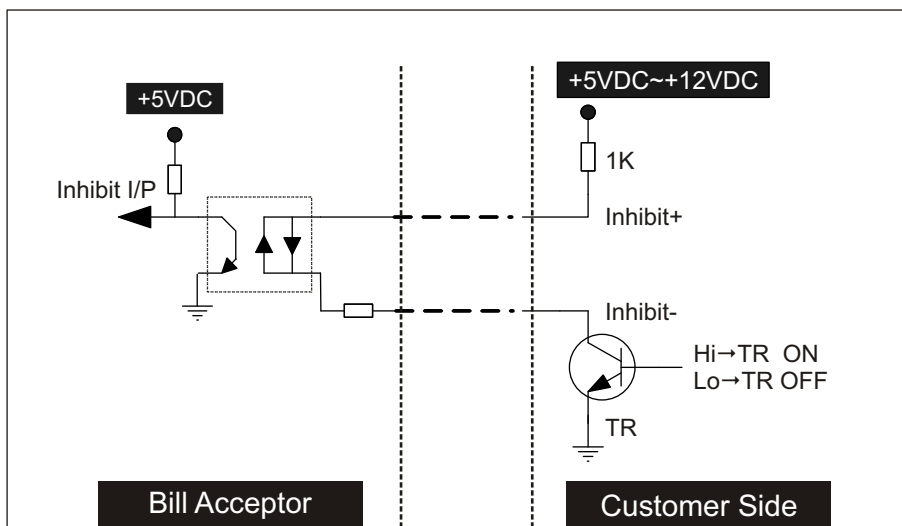
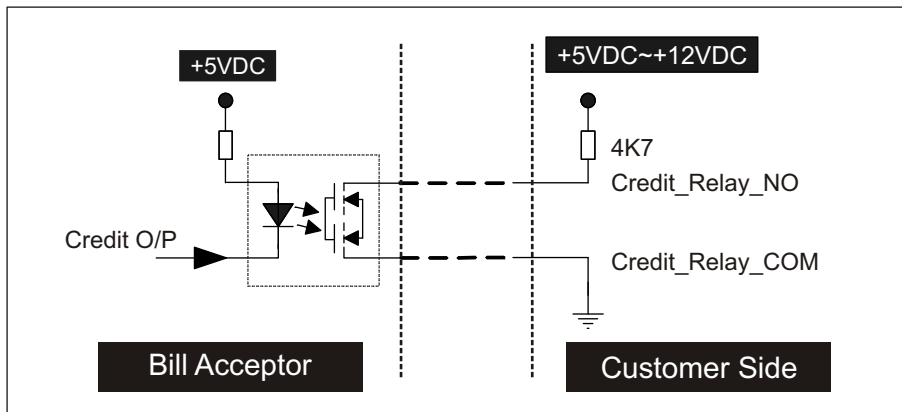

BA Status	DIP SW Setting		Control Signal
Inhibit	Inhibit Active	Low	Low
		High	High
Enable	Inhibit Active	Low	High
		High	Low

ccTalk Interface.

Figure 90.

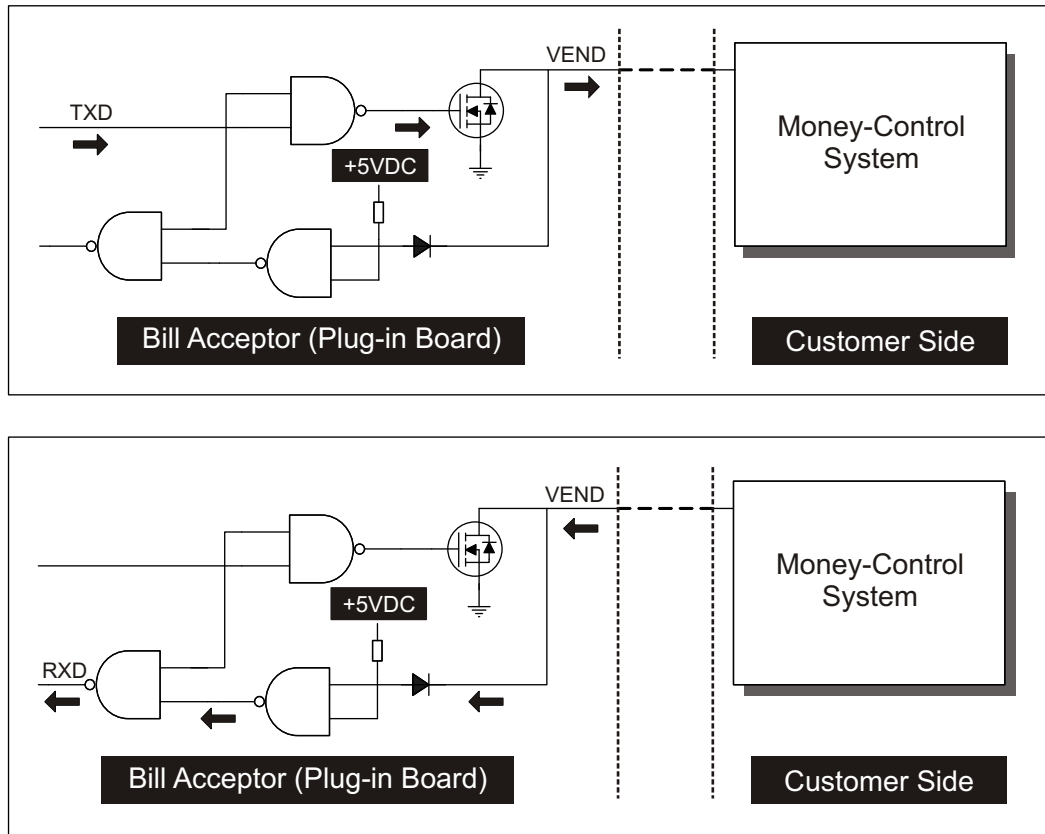

ICT/ GBA/ CCNET/ ID003 Interface.

Figure 91.

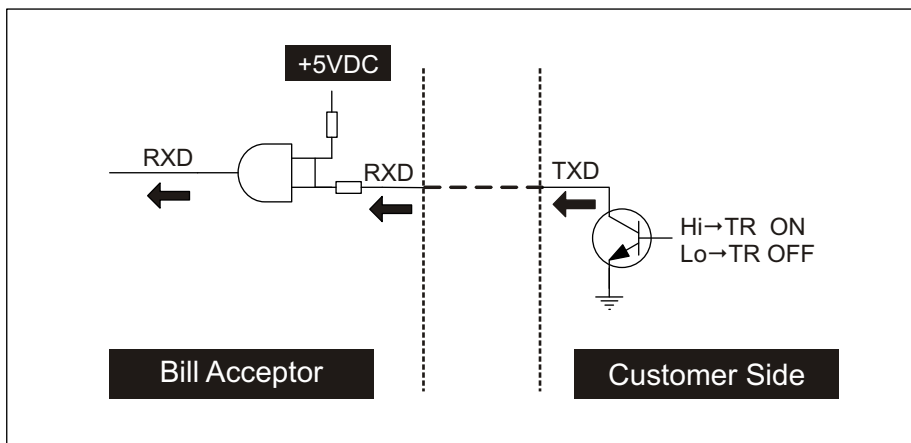
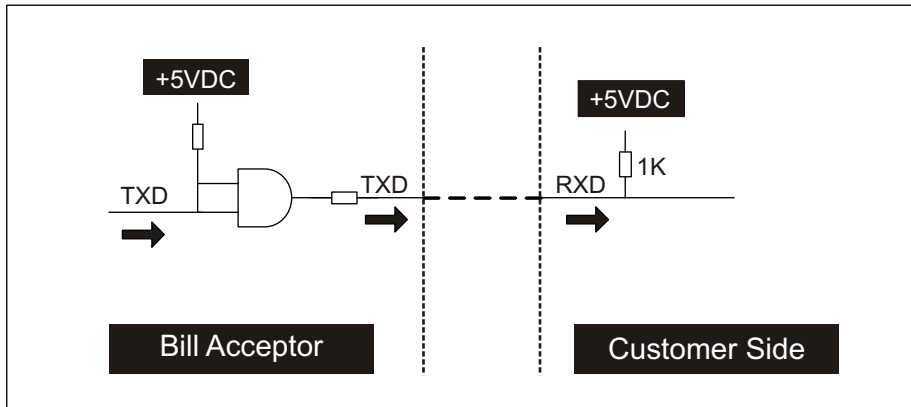

Parallel Interface.

Figure 92.

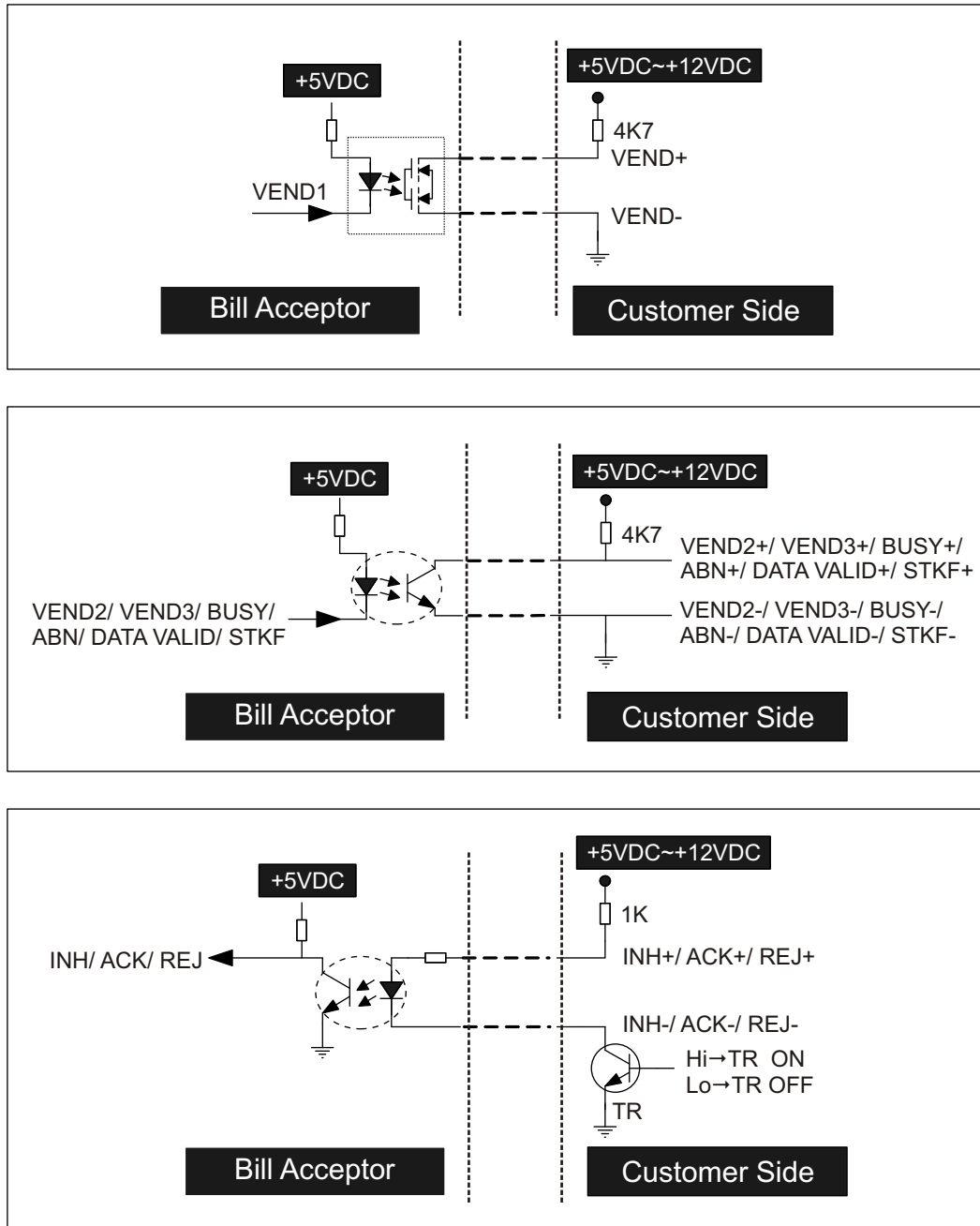

IGT Interface.

Figure 93.

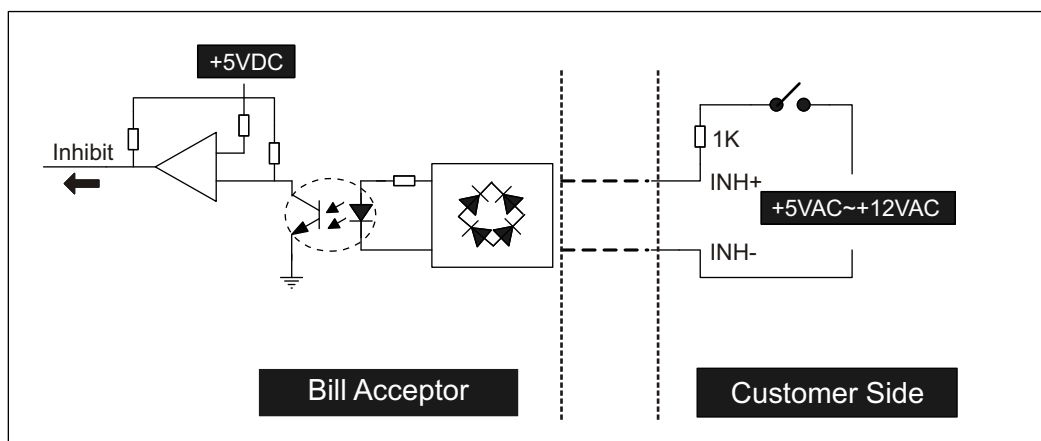
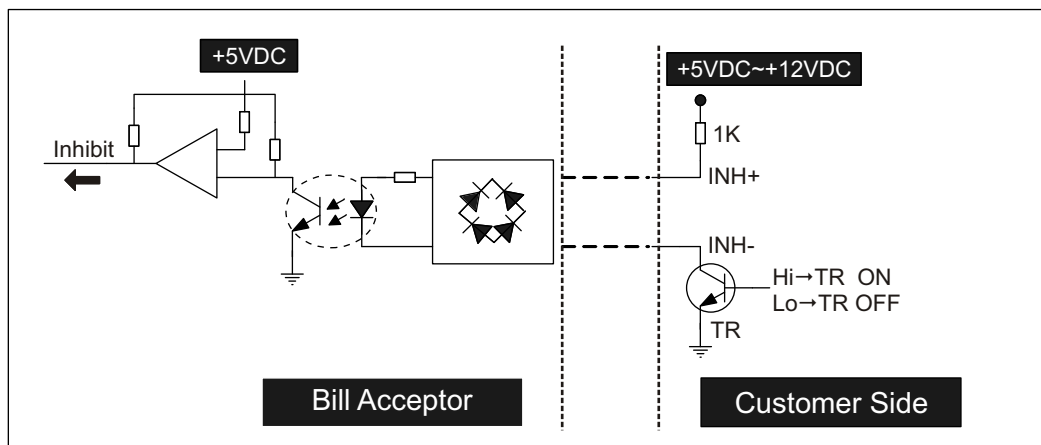
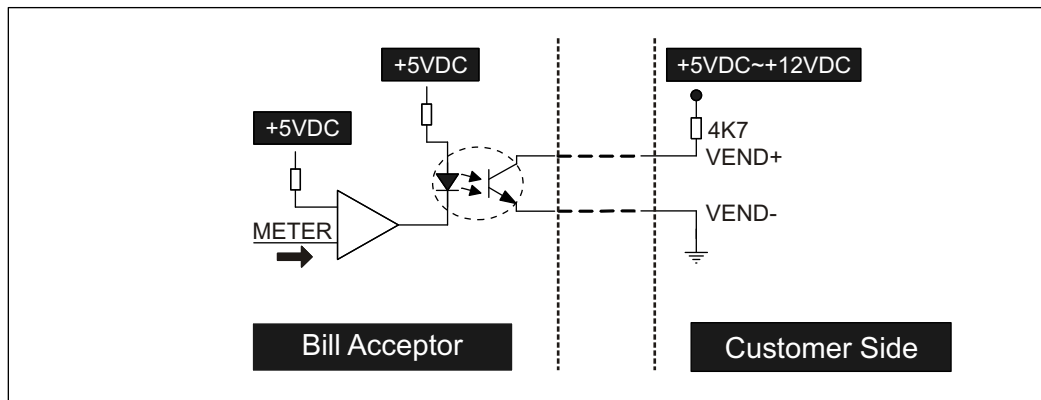

MDB Interface.

Figure 94.

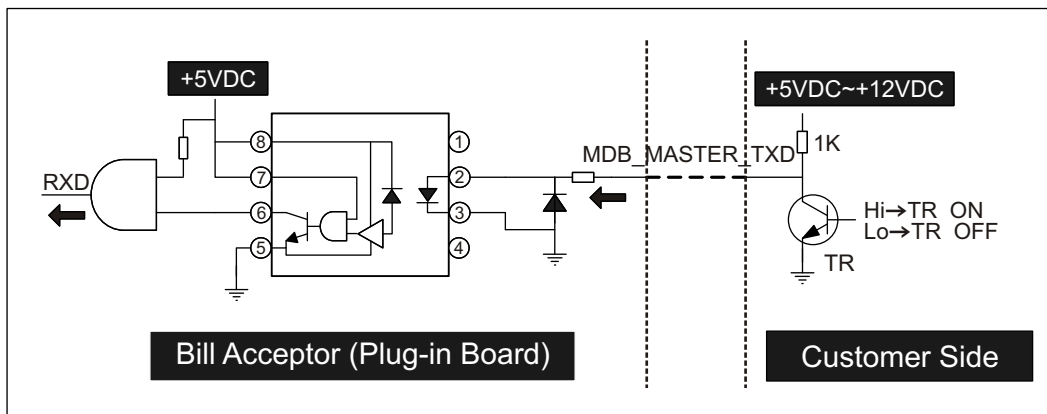
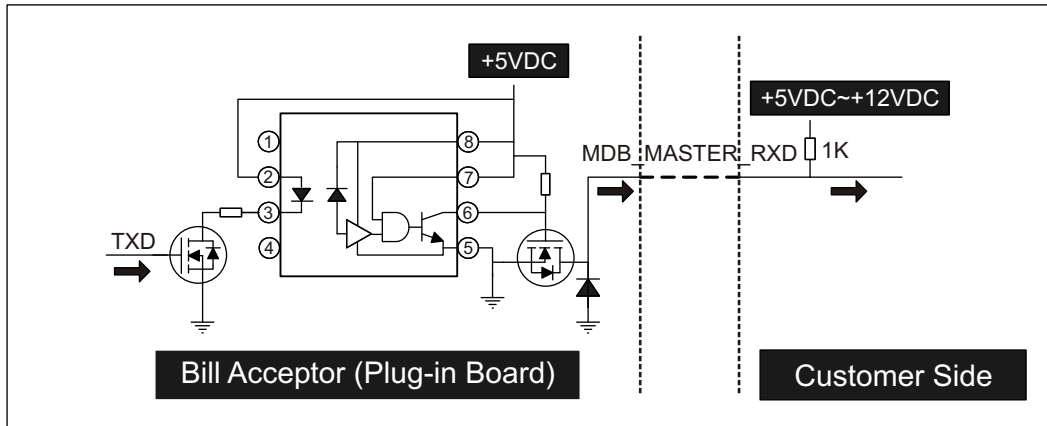



4. Maintenance :

Foreign objects on the LED or sensor may cause bill jammed and decrease acceptance rate. To make sure bill acceptor always works smoothly, please clean the internal parts regularly.

To clean internal parts, please follow the steps below:

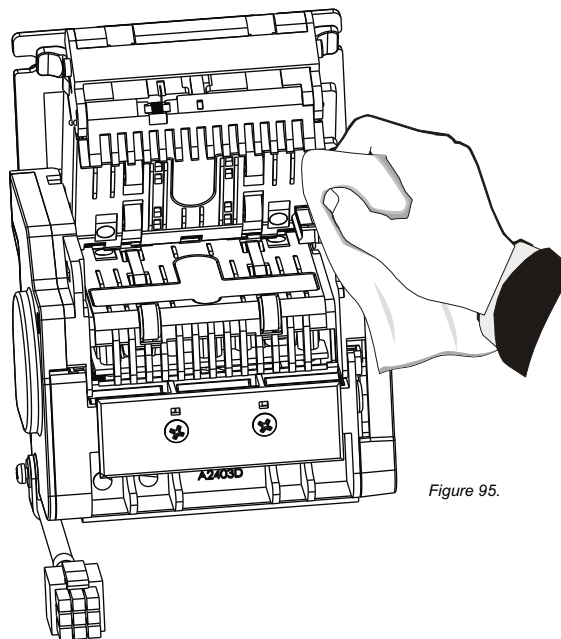
1. Turn off the power of Bill Acceptor.
2. Open LED Assembly.
3. Use soft cloth or cotton swab to clean internal parts and bill path.



	Maintenance Notice <i>(Any improper maintenance will result invalid warranty.)</i>	
	Recommended	Mild, non-abrasive, soap water.
	DO NOT USE	Organic solvent , Alcohol, Volatility liquid.

5. Trouble Shooting :

5-1. Introduction

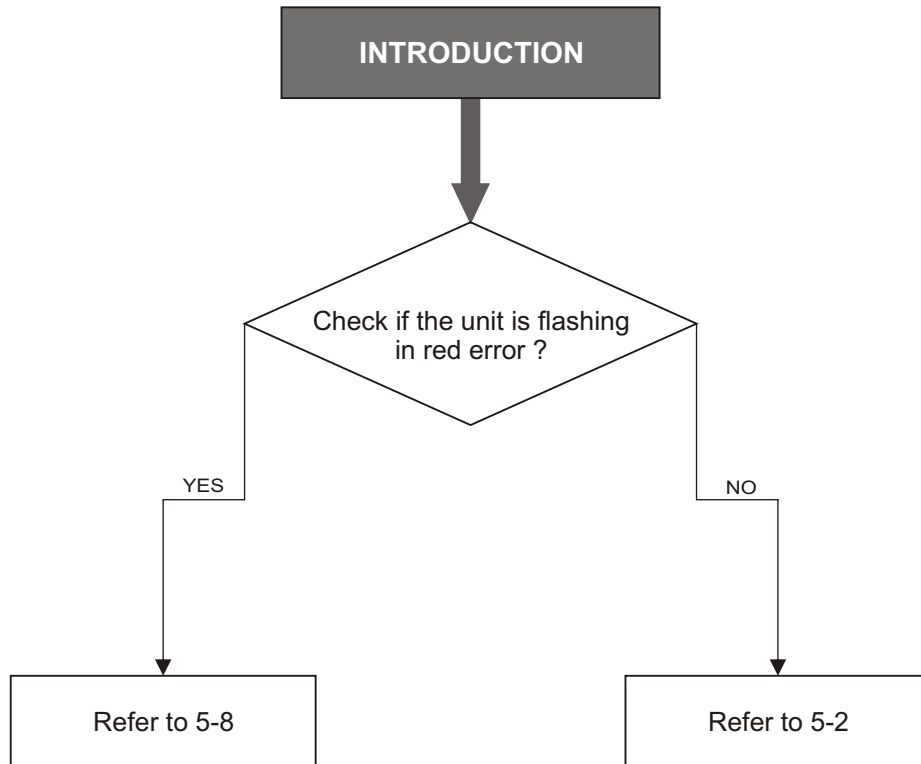
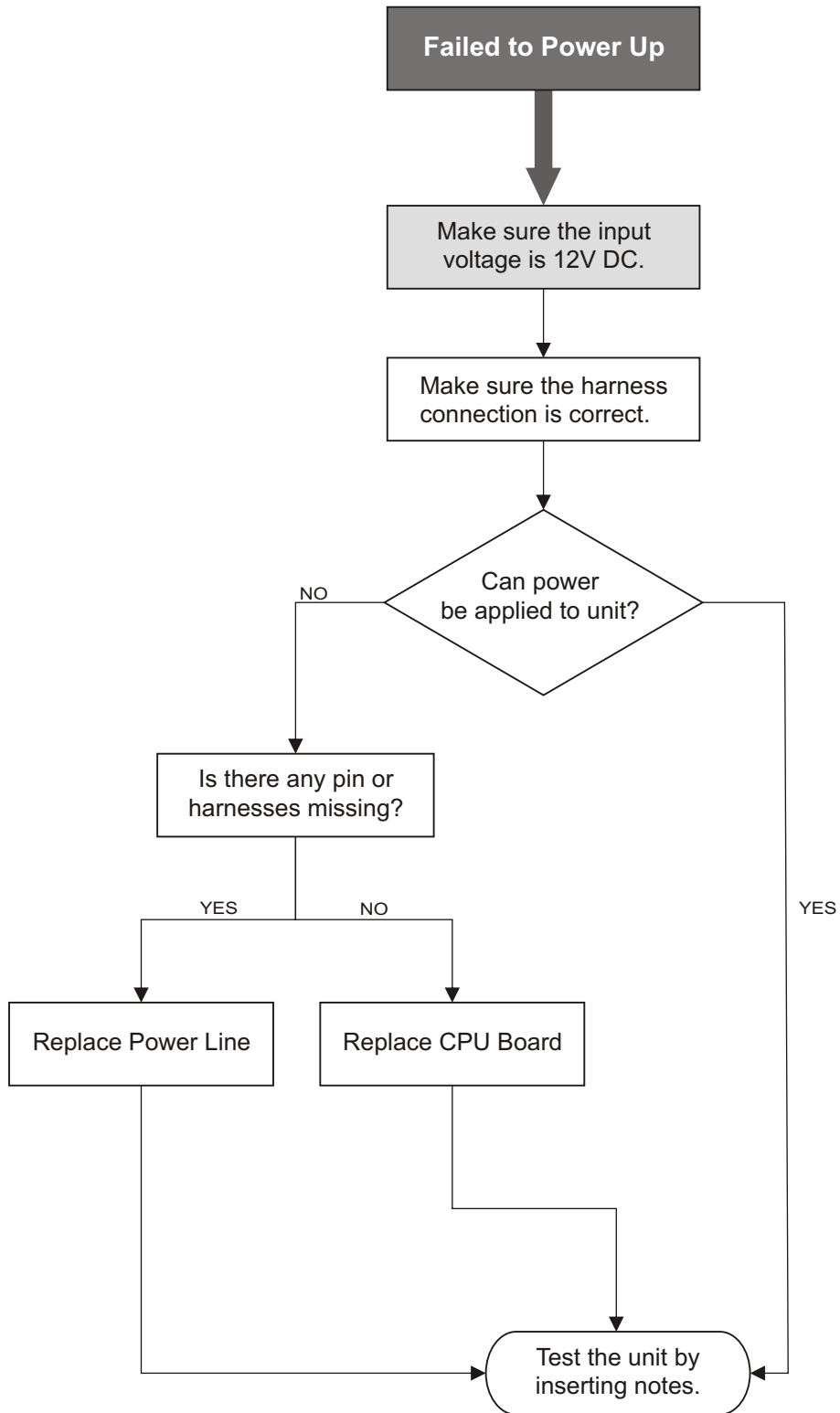

Figure 96.

5-2. Failed to Power Up

Figure 97.



5-3. Failed to Communicate

Figure 98.

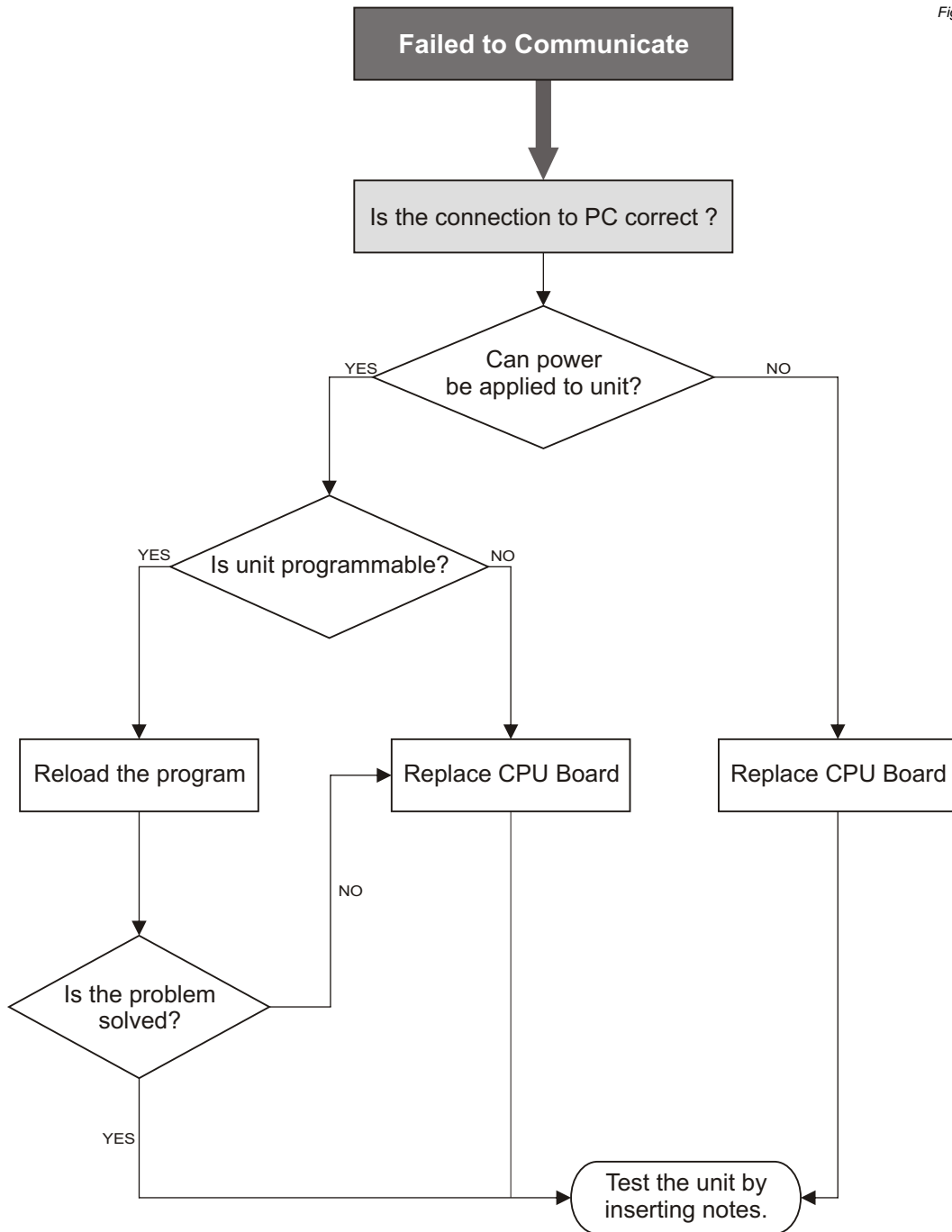

5-4. Low Acceptance

Figure 99.

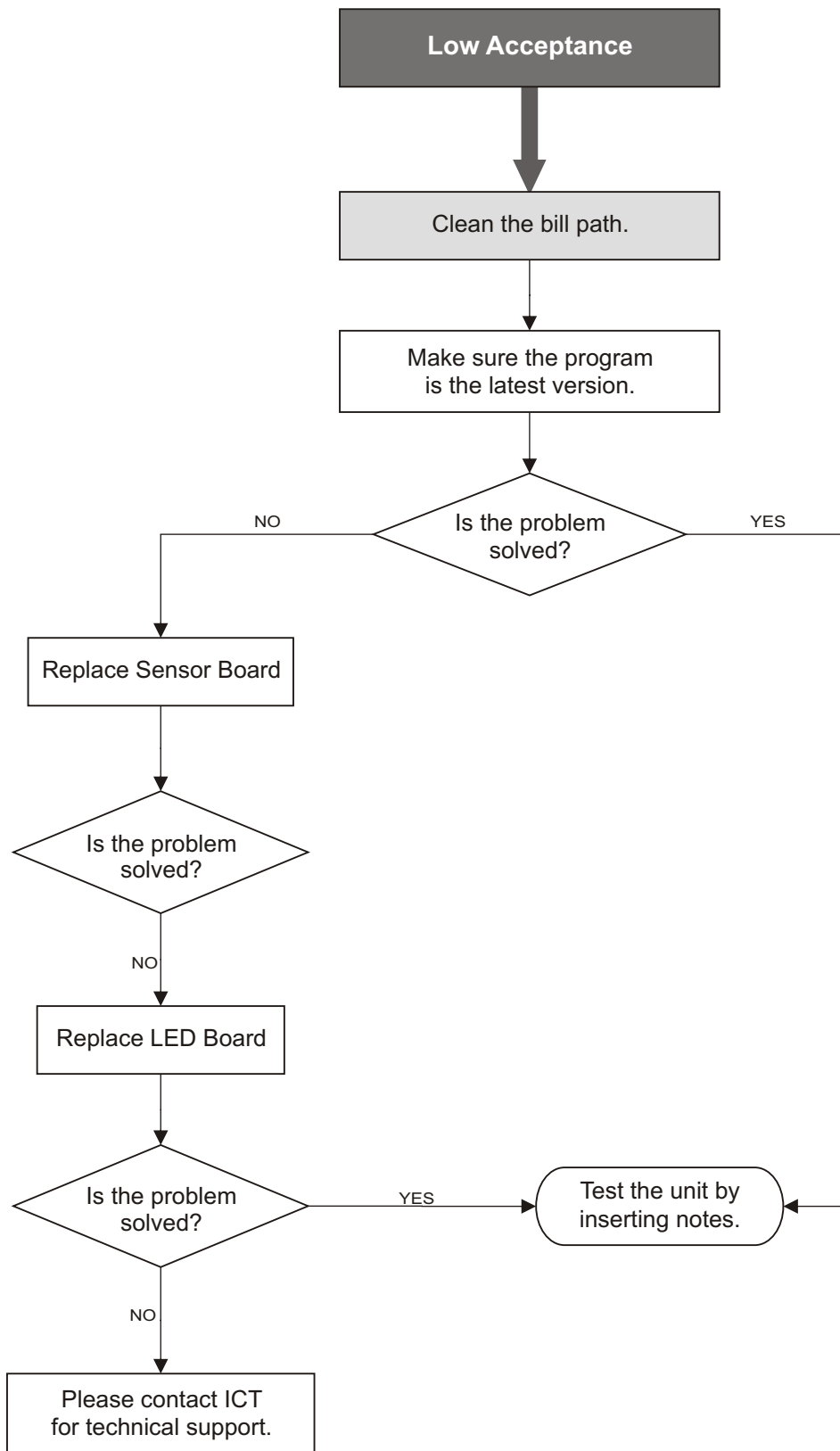

5-5. Wrong Credit Output

Figure 100.

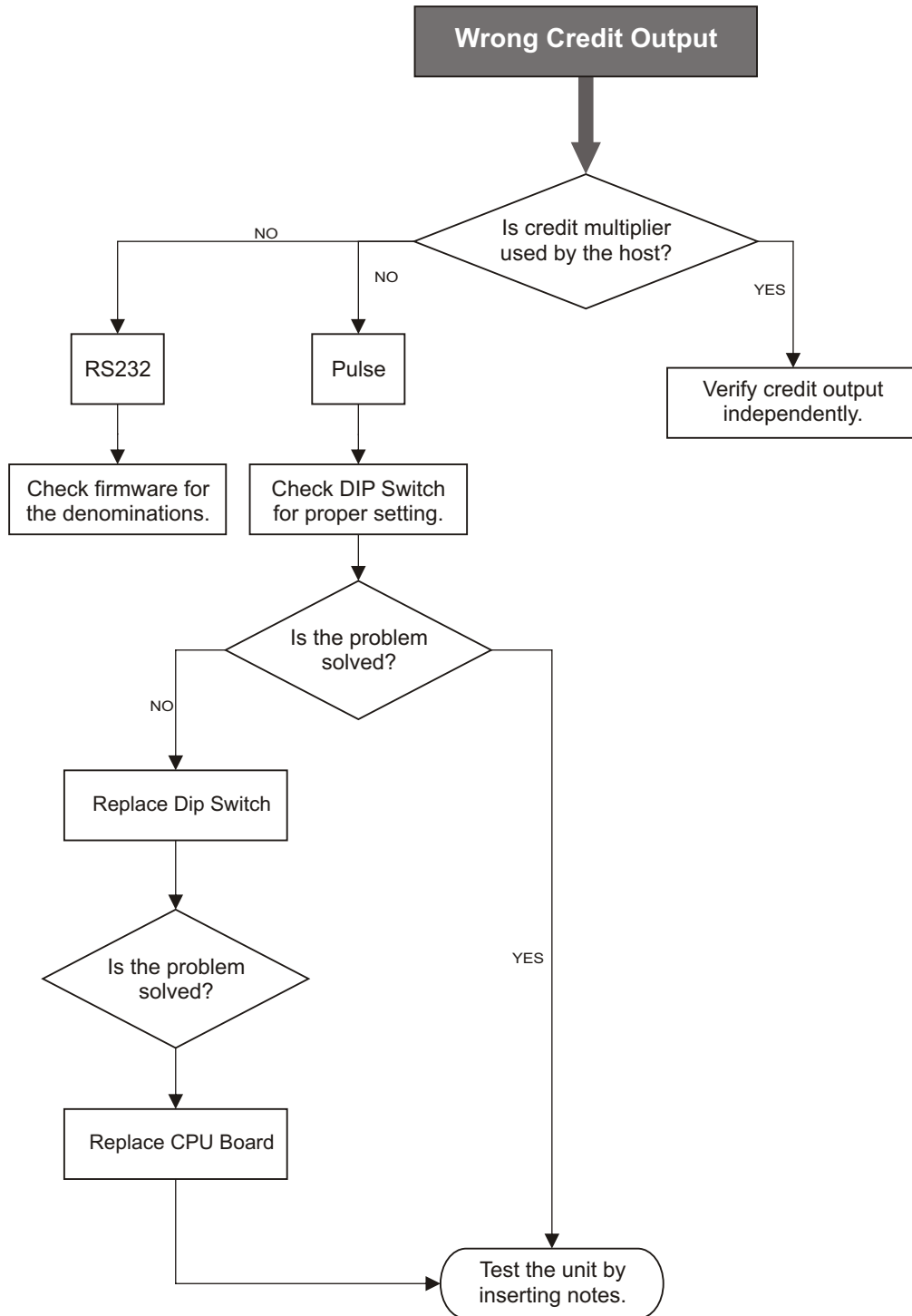

5-6. Motor with Strange Sound

Figure 101.

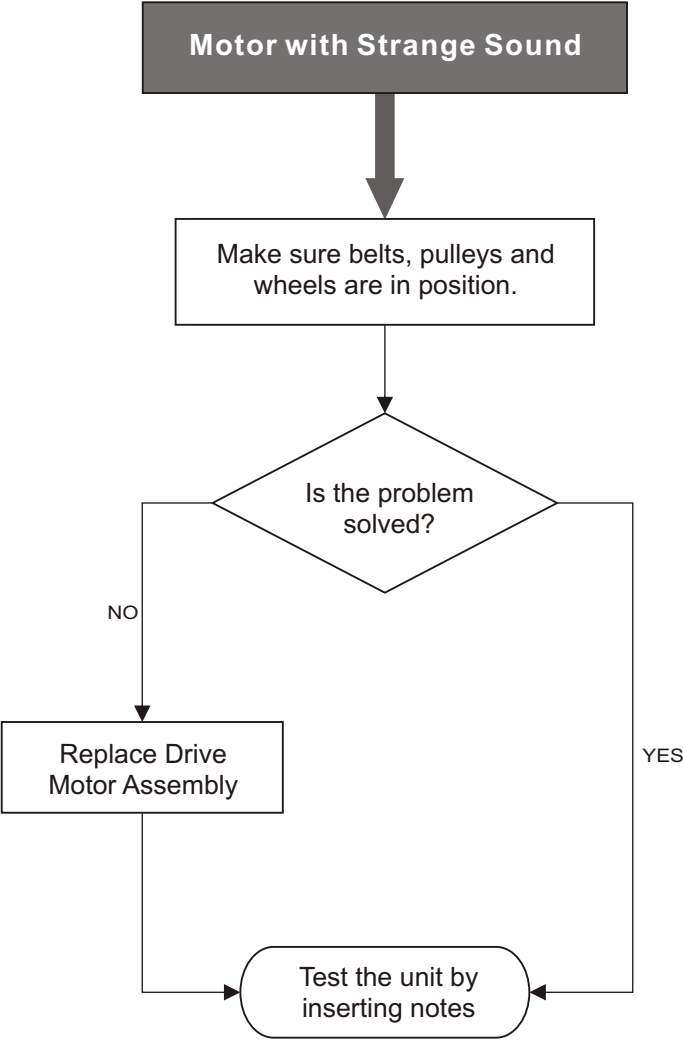

5-7. No Diagnostic LED Status

Figure 102.

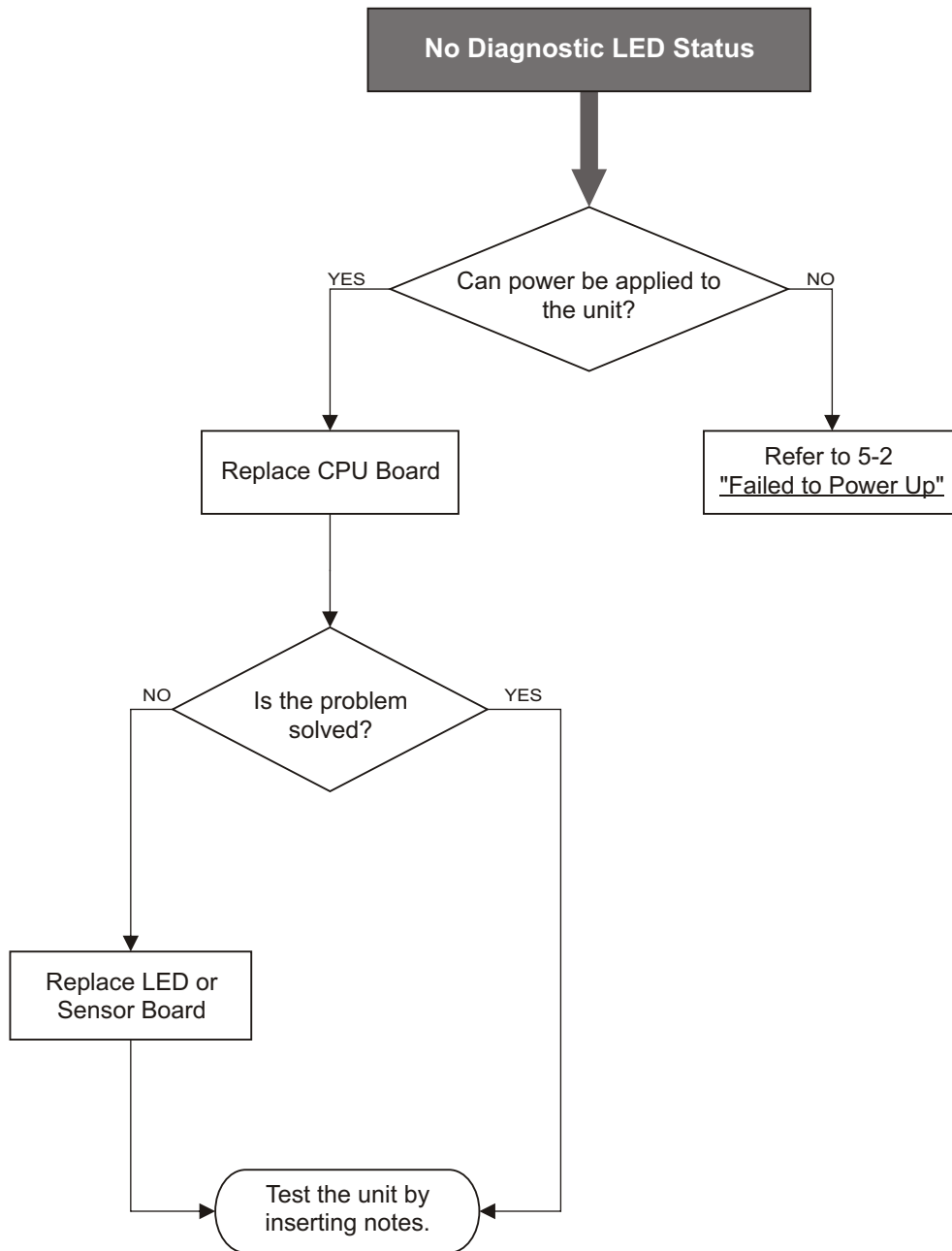

5-8. Bill Acceptor Error Code

Figure 103.

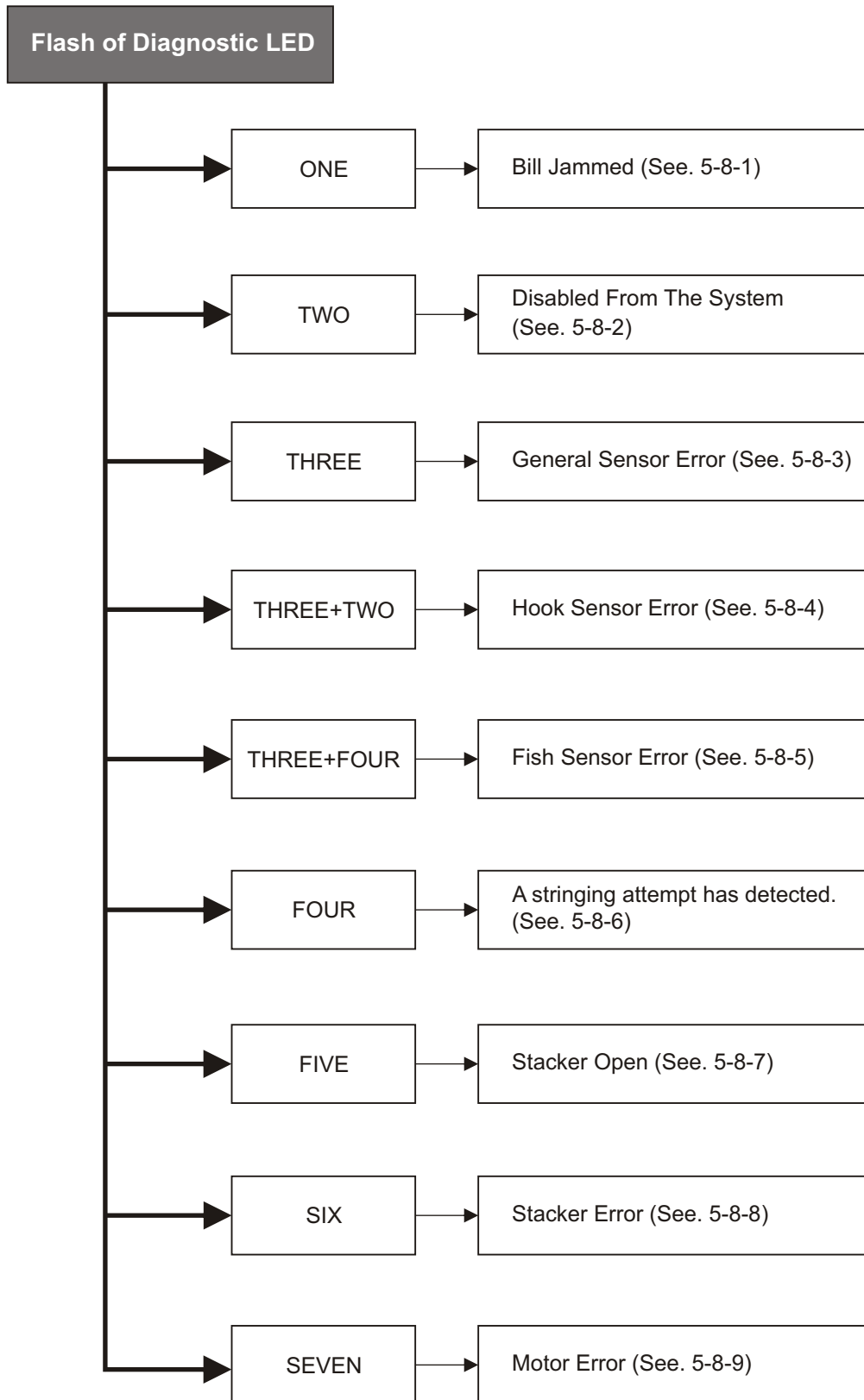

5-8-1. One Flash

Figure 104.

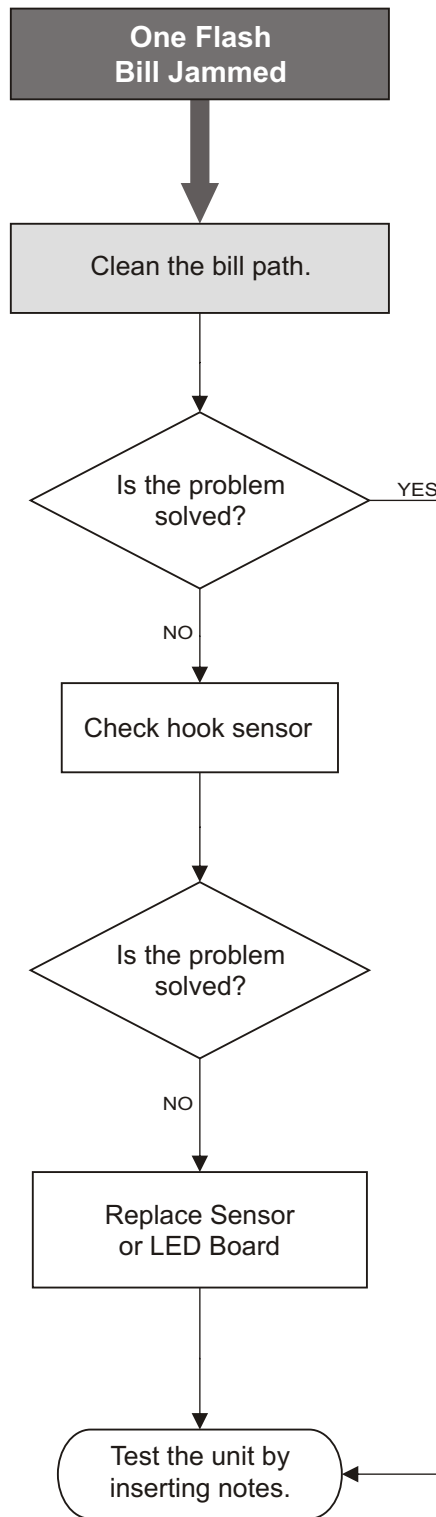

5-8-2. Two Flashes

Figure 105.

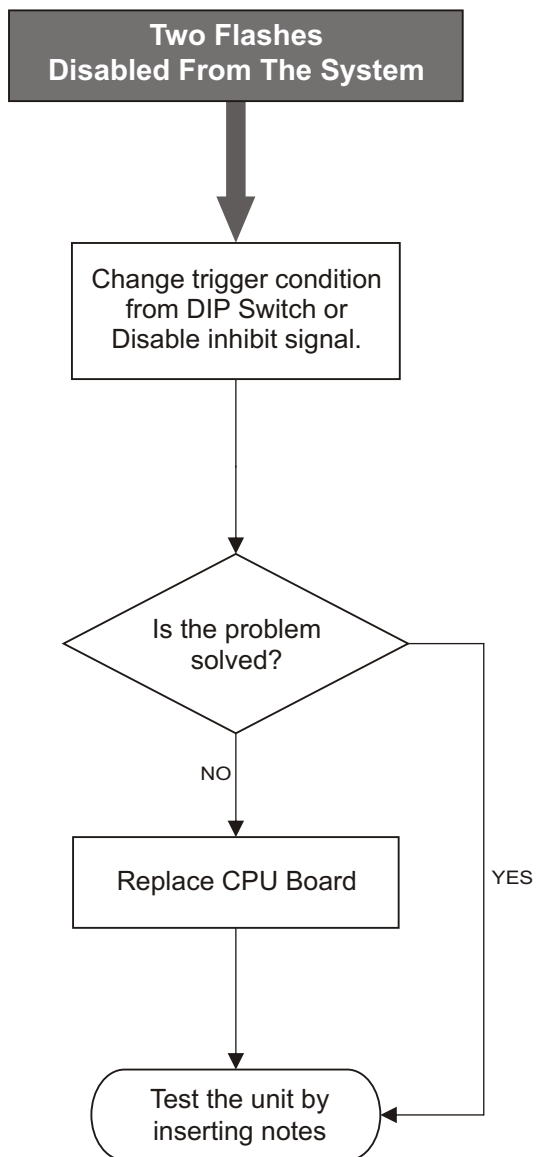

5-8-3. Three Flashes

Figure 106.

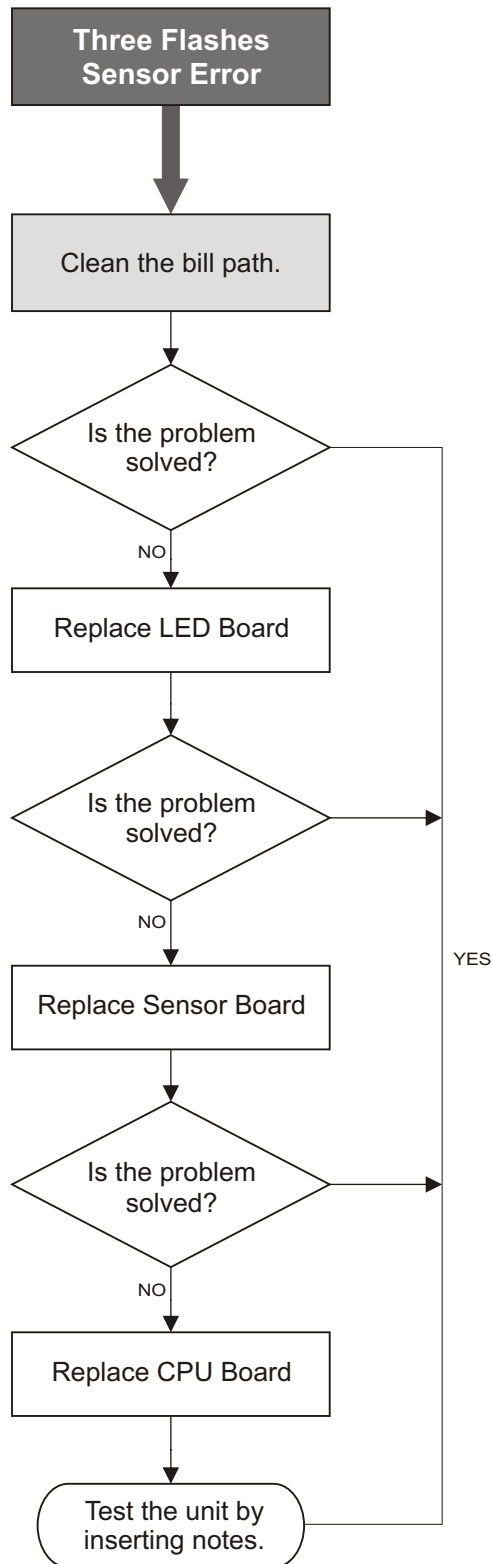

5-8-4. Three+Two Flashes

Figure 107.

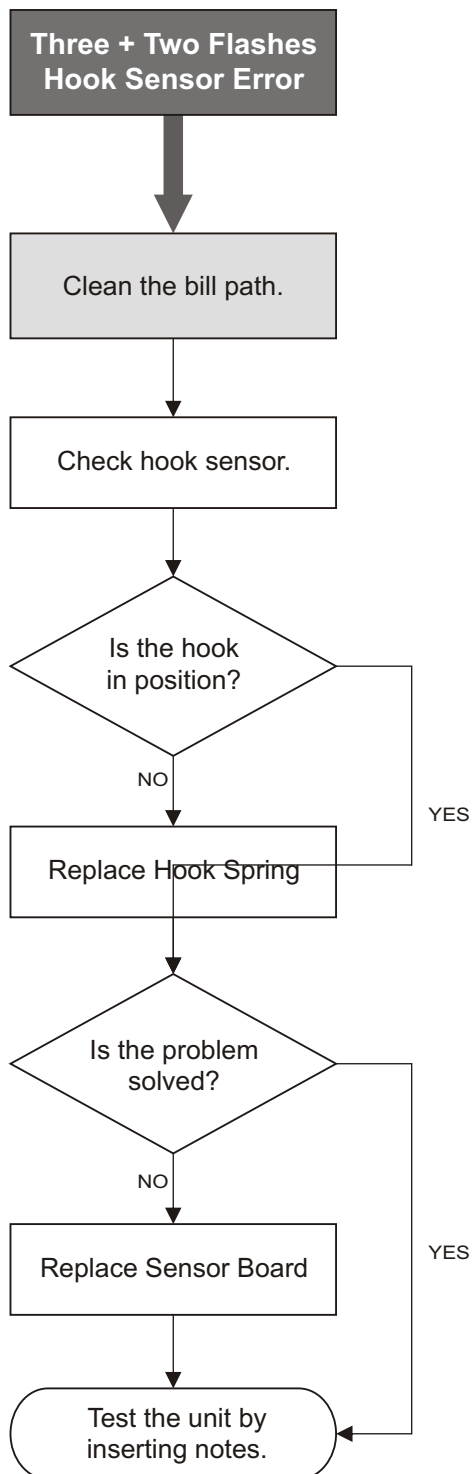

5-8-5. Three+Four Flashes

Figure 108.

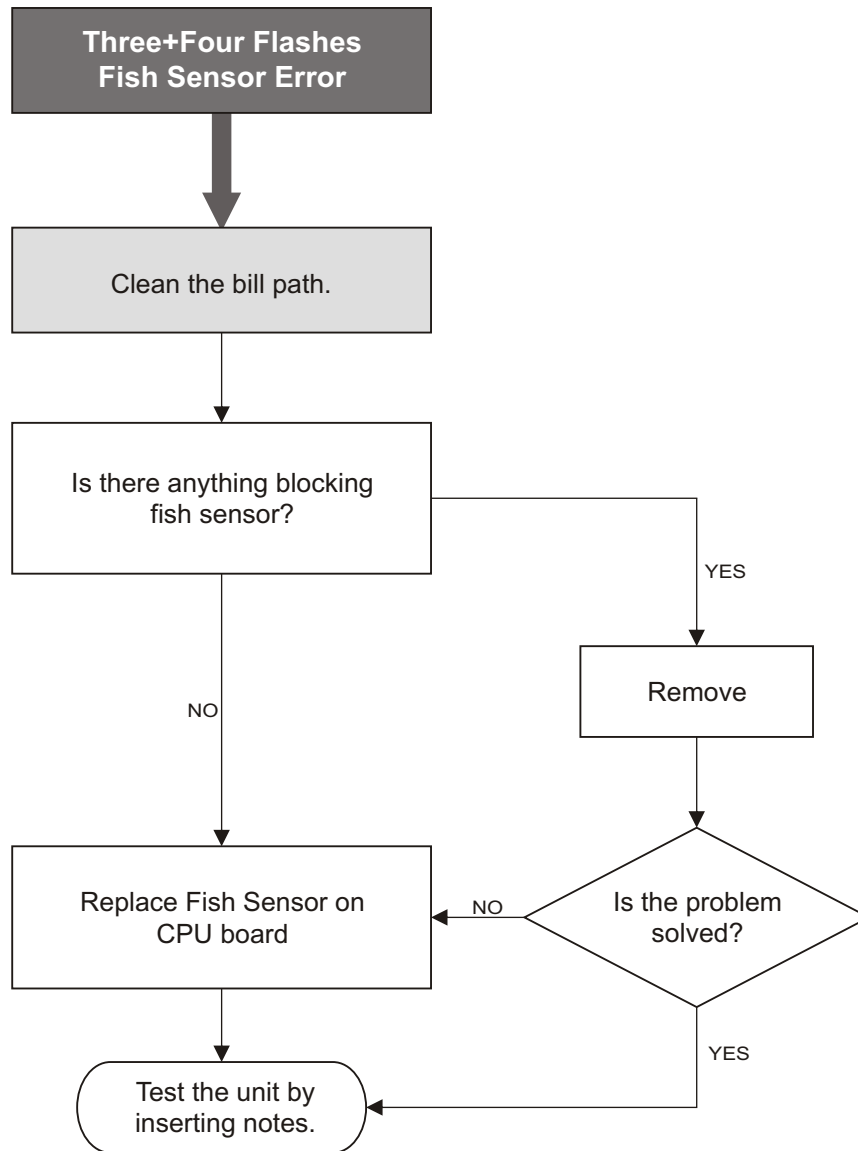

5-8-6. Four Flashes

Figure 109.

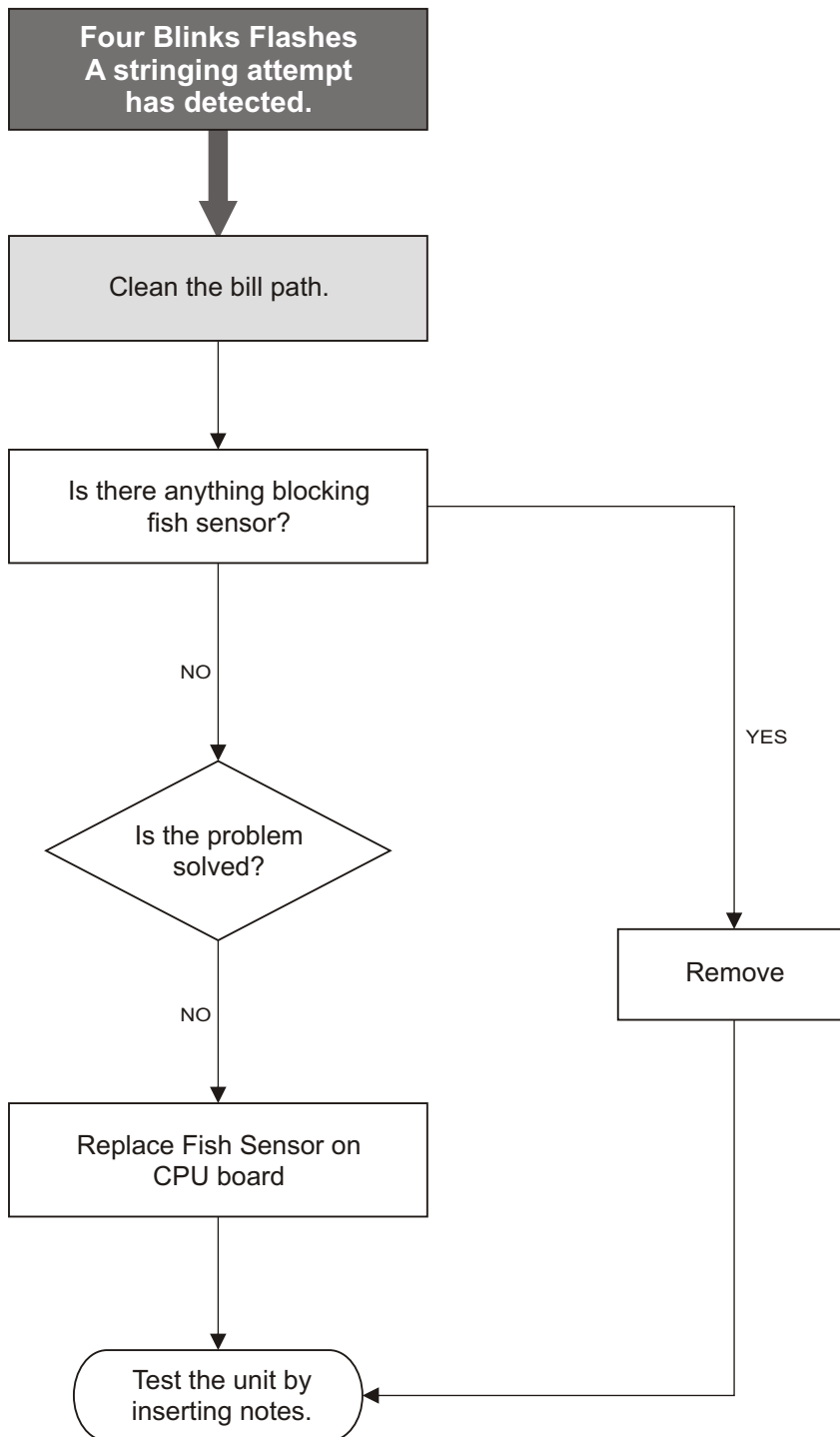

5-8-7. Five Flashes

Figure 110.

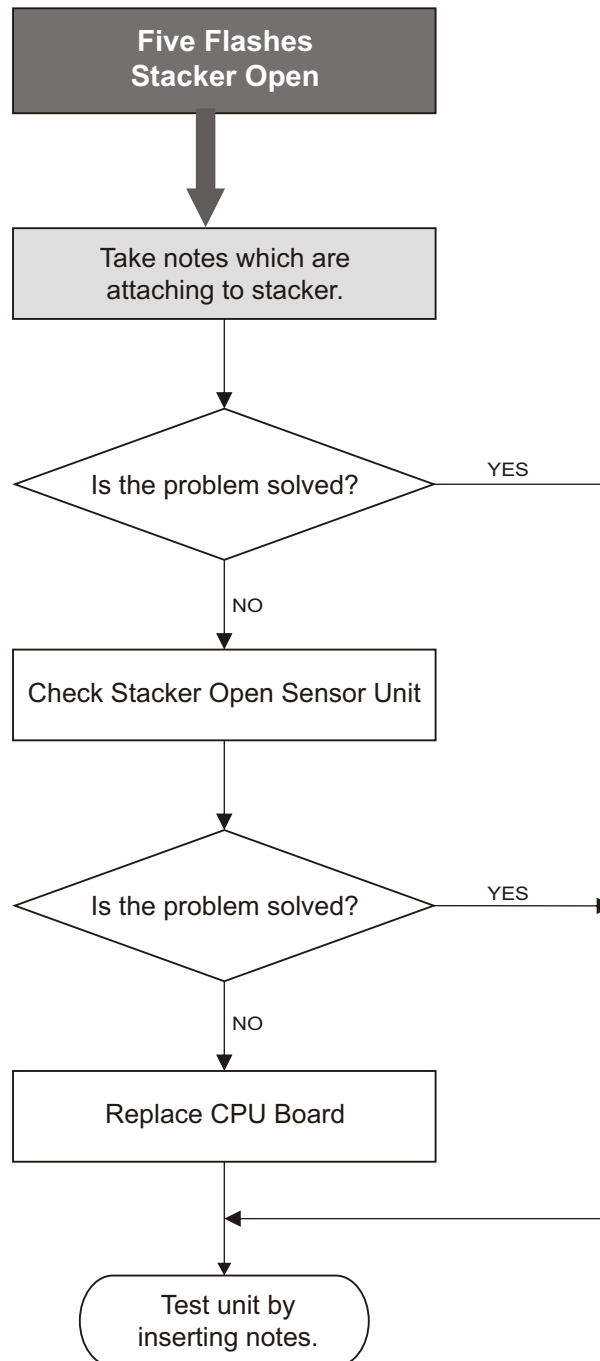

5-8-8. Six Flashes

Figure 111.

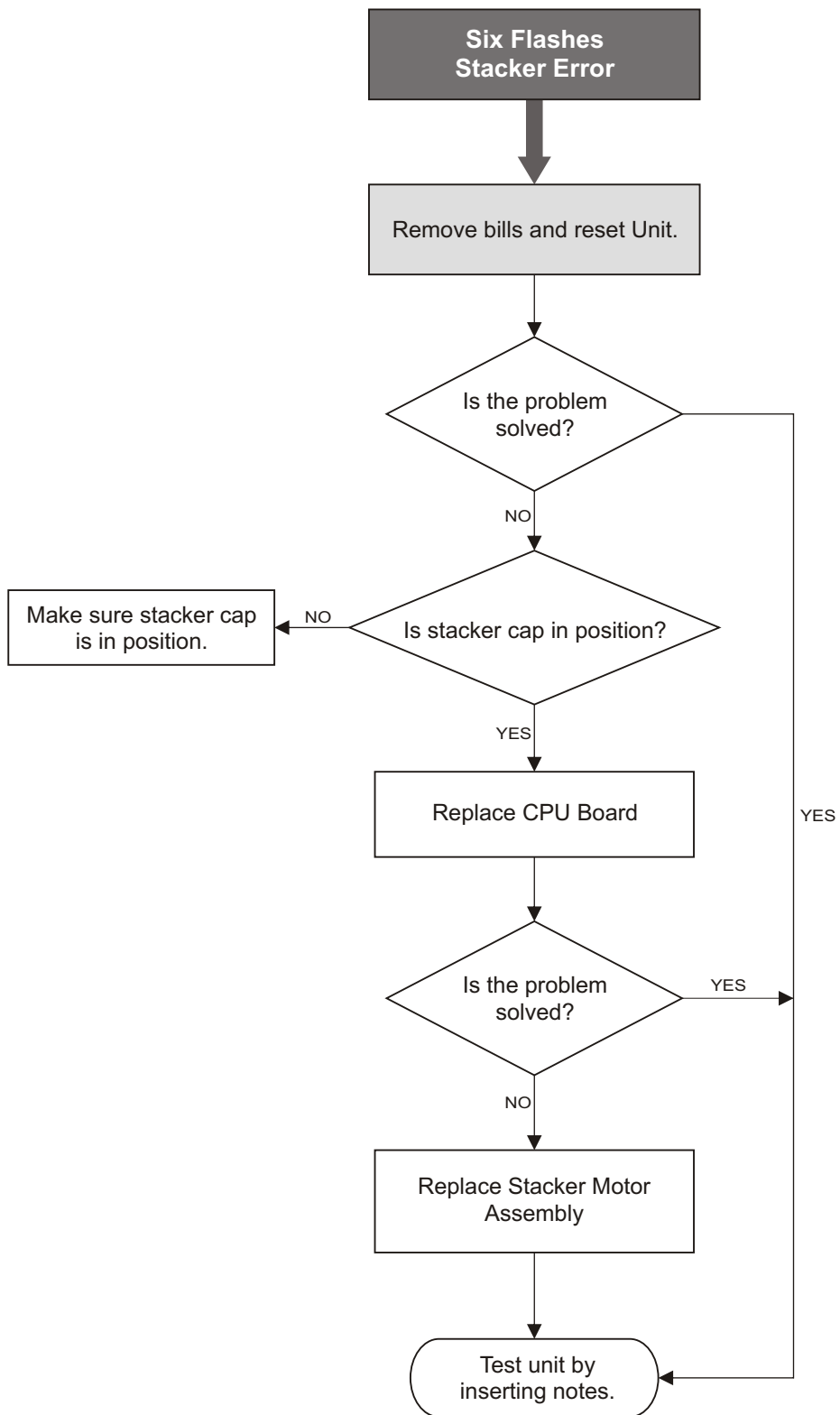

5-8-9. Seven Blinks

Figure 112.

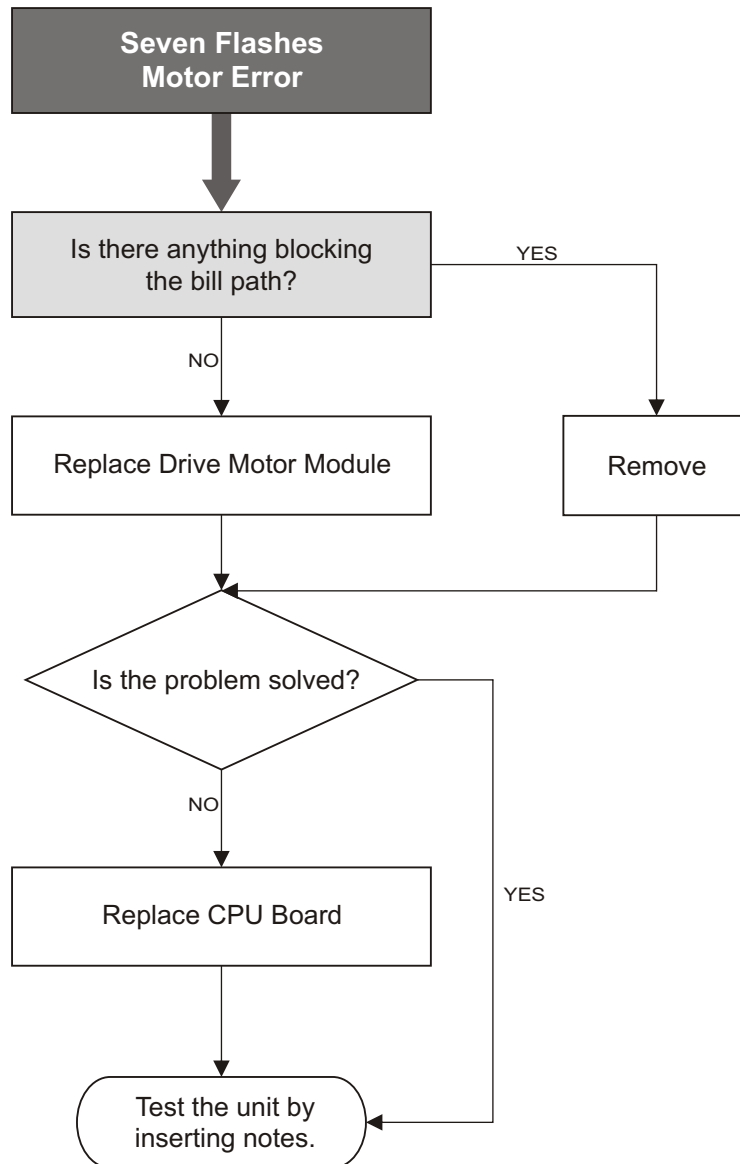

6. Parts and Assembly Views :

6-1. Exploded Views

L70(#) Main Unit Module

Figure 113.

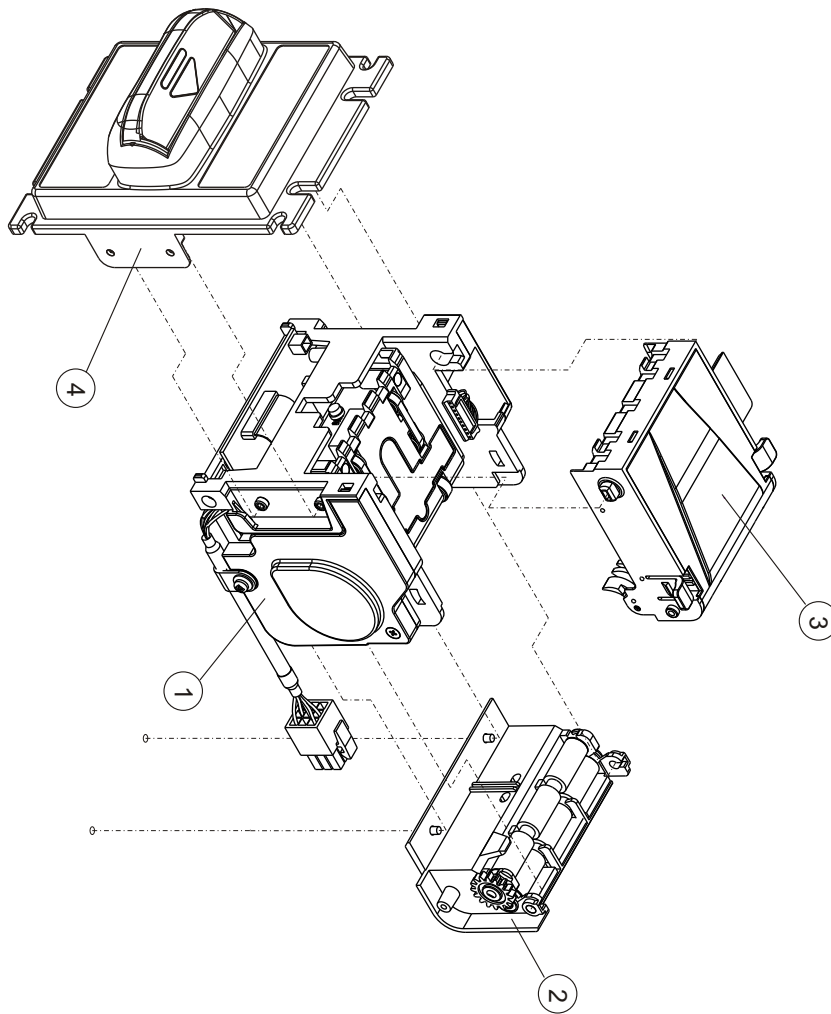

Order	Part number	Appellation	Quantity
1	3RBA-DWN19001	Lower base module (L70-67mm)	1
2	3RBA-ROL09001	Roller mount module-P70	1
3	3RBA-UPX19001	Upper base module (L70-67mm)	1
4	A2916000-R	L70 Face plate unit (67mm)	1

Table 2.

L70(#) Lower Base Module

Figure 114.

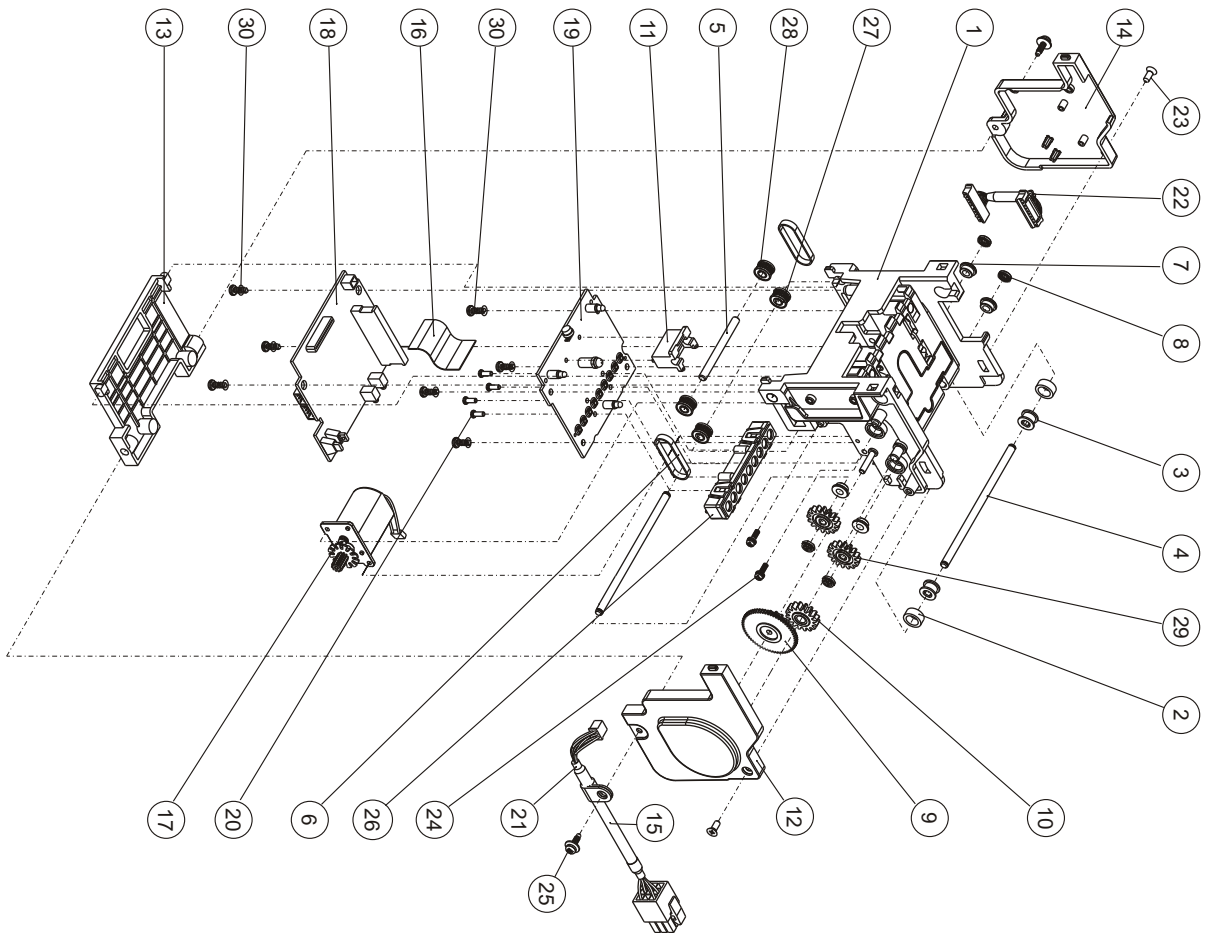

Order	Part number	Appellation	Quantity
1	A2948A00-R	Lower base assembly (67mm)	1
2	E50190-R	Plate belt (D7.0*TD9.9*T14.0)	2
3	A29170-R	Plate belt roller	2
4	B12310-R	Belt roller axle type D	2
5	B12320-R	Belt roller axle	1
6	E50180-R	Belt (34MXL-3.2)	2
7	C18050-R	Axle bush-6	4
8	A28780-R	M3 Plastic retaining ring	4
9	F10370-R	Gear (M0.5*1.60-M1.0*1.12)	1
10	F10140-R	Gear type O (M1+T16)	1
11	A29190-R	Belt roller fixed stand	1
12	A29140-R	Right gear cover plate	1
13	A2915A-R	Belt roller type D	1
14	A2913A-R	CPU PCB board	1
15	L20730-R	Cable fixed ring (black) PC-3	1
16		Cloning kit	1
17	3RBA-MOT07000	Motor module (L70)	1
18	AA3180**	CPU PCB board	1
19	AA3188**	LED PCB board	1
20	S20080	D2.3x6 Tapping screw (black-TP2)	4
21		Outside power wire	1
22		Sensor and LED board wiring	1
23	S30760	D3x8 Flat counter-sunk head tapping screw (black zinc plating-TP2)	2
24	S20150	M2.6x8 Cup headed screw with washer (black zinc plating)	2
25	S30890	M3*10 Mechanical black zinc plating screw with large washer	2
26	3RBA-LEND1001	Optical lens unit (L70-circular hole)	1
27	A20150-R	Belt roller type D	2
28	A20140-R	Belt roller type O	2
29	F1038A-R	Gear (M1x16)	2
30	S30750	3*8 Tapping screw (black zinc plating) TP2	7

L70(#) Upper Base Module

Figure 115.

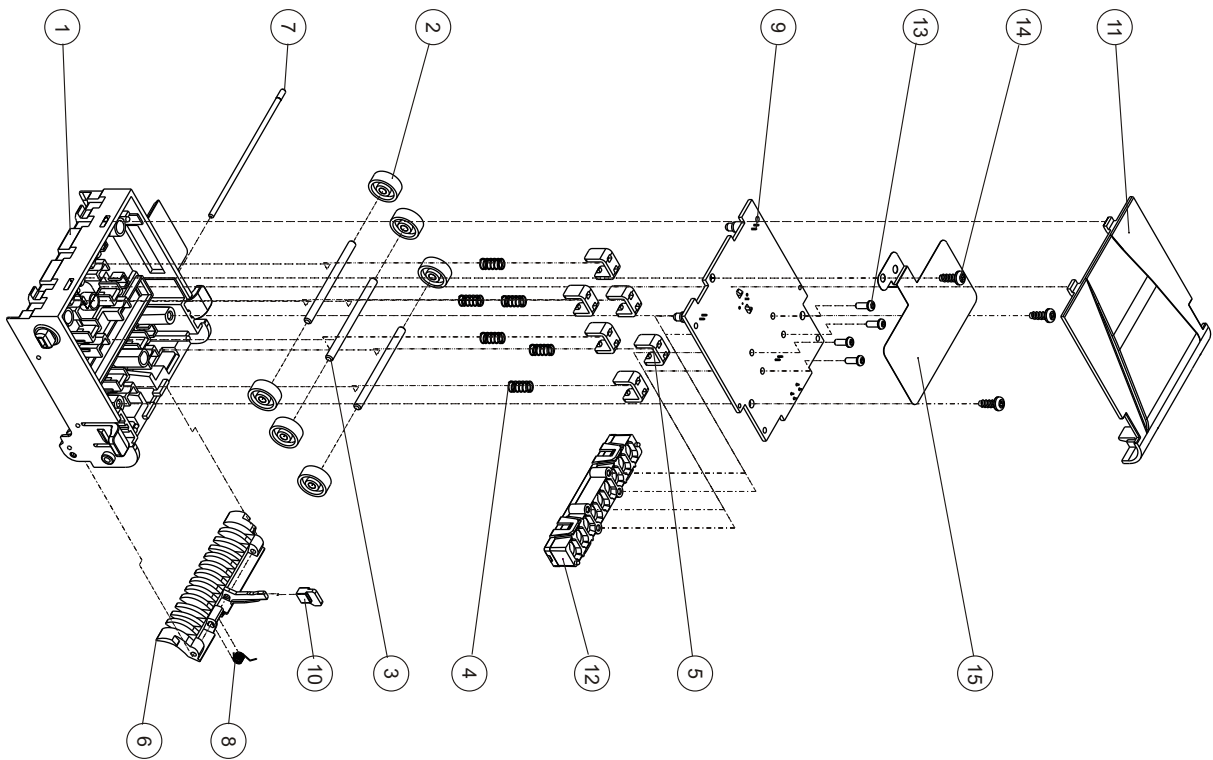

Revision	Order	Part number	Appellation	Quantity
V1.0	1	A2947000-R	Upper base assembly (67mm)	1
V1.0	2	A29560-R	Driving idler (white)	6
V1.0	3	B12300-R	Idler axle	3
V1.0	4	G10720-R	Idler compression spring	6
V1.0	5	A26840-R	Idler spring hook	6
V1.0	6	A26840-R	Security tooth	1
V1.0	7	B11270-R	Security shaft (70UF)	1
V1.0	8	G10950-R	Security tooth spring	1
V1.0	9	A29180-R	Security tooth raising mount	1
V1.0	10	A29120-R	Upper base cover plate	1
V1.0	11	AA318C**	Sensor CPU board	1
V1.0	12	3RBA-LEN01001	Optical lens unit (L70-circular hole)	1
V1.0	13	S20060	D2.3x6 Tapping screw (black-TP2)	4
V1.0	14	S30750	3*8 Black zinc plating tapping screw TP2	3
V1.0	15	C18540-R	Conductive piece	1

L70(#) Roller Mount Module

Figure 116.

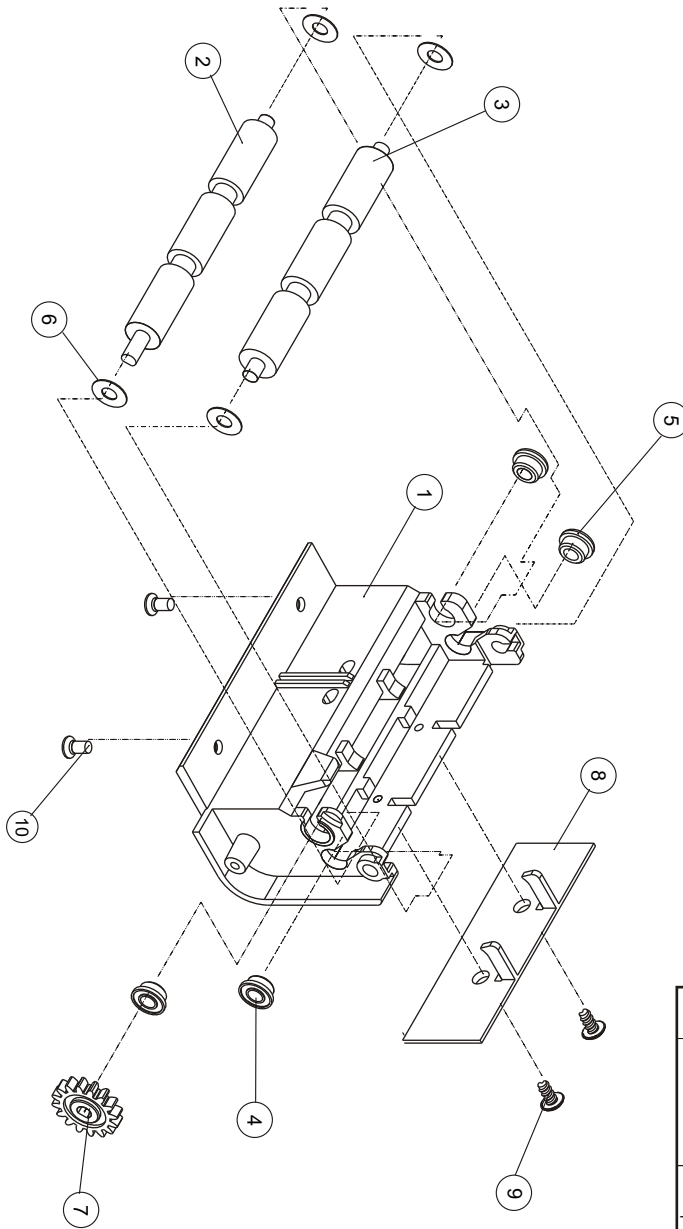

Order	Part number	Appellation	Quantity
1	A2403D-R	Rubber roller mount (B70UF)	1
2	B5011A-R	Rubber roller (B)	1
3	B5010A-R	Rubber roller (A)	1
4	CU-112B-R	Bushing (A)	2
5	CU-113A-R	Bushing (B)	2
6	CU-976-R	Nylon washer (WS4-3)	4
7	F1038A-R	Gear (M1x16)	1
8	A2401B-R	Guidance plate	1
9	S30580	3/6 Large flat head tapping black zinc plating screw TP2	2
10	S30590	M3*6 Flat counter-sunk head black zinc plating screw	2

L70(#) Stacker Module

Figure 117.

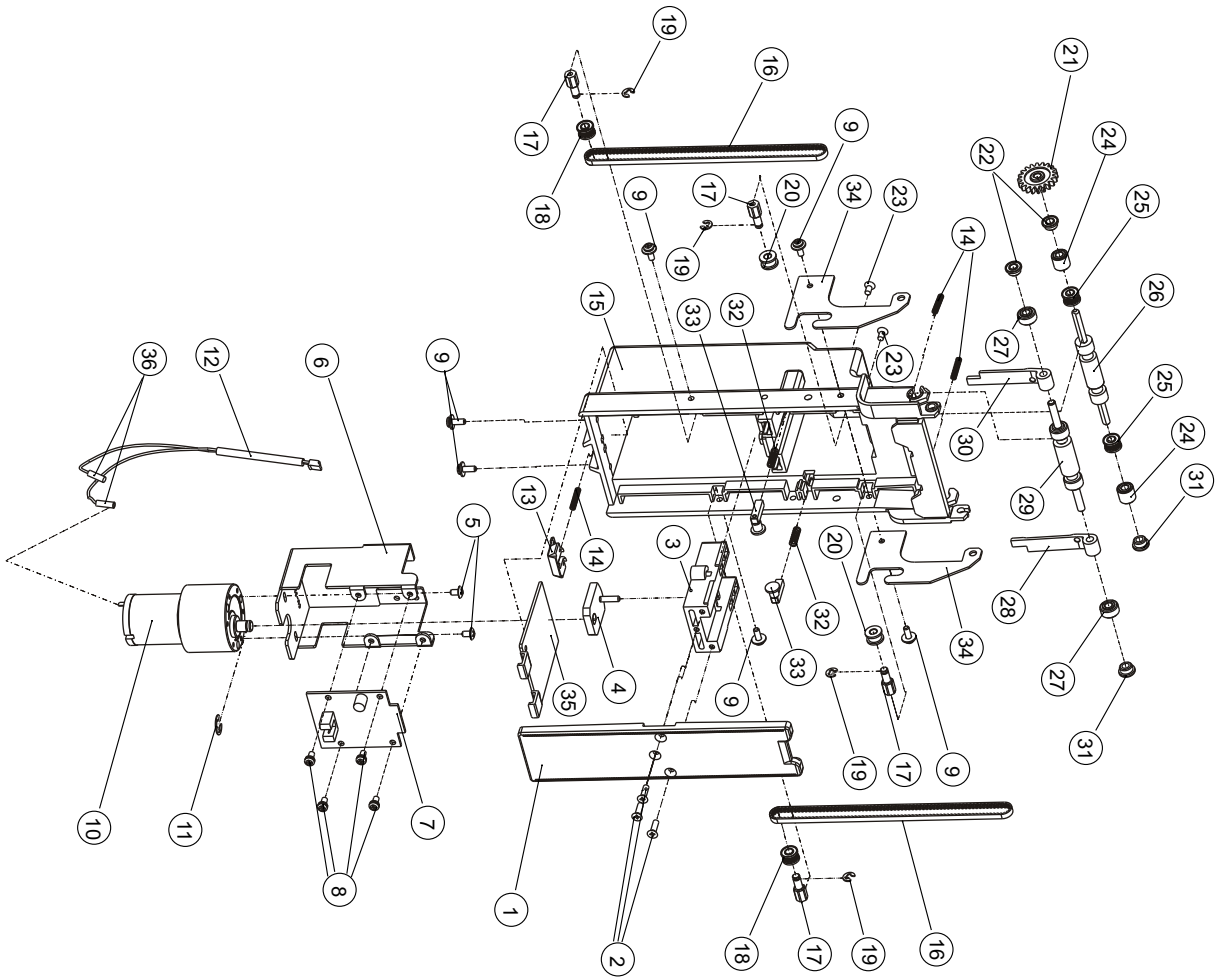

Order	Part number	Appellation	Quantity
1	A2031D	Stacking plate	1
2	M10030	M3x10 Flat counter-sunk head tapping screw	3
3	US-116E	Sliding block	1
4	US-706B	Torque force motor cam	1
5	RO-917	M3x5 Flat headed screw	2
6	C16030	Motor mount	1
7	3BA-AA248-G1	Motor plate	1
8	BA-041-1	M3x6 Cup headed screw (black)	4
9	BA-038	M3x8 Cup headed screw with washer (black)	6
10	D10420	Torque force motor	1
11	BA-037	Retaining ring type E (E-5)	1
12	CU-964	2P wiring	1
13	A20270	Bill box fixed sliding block	1
14	US-508B	Belt roller conductive piece spring	3
15	CU-121E	Stacker	1
16	E50020	Belt 140XML 3.2	2
17	B30130	Belt axle	4
18	A20140	Belt roller (O TYPE)	2
19	BA-036	Retaining ring type E (E-3) (N)	4
20	B30050	Guide pulley	2
21	F10380	Gear	1
22	CU-112B	Bushing (hole drilling)	2
23	RO-914	Flat counter-sunk head tapping screw (black) 3x6#12	2
24	A2040A	Bushing	2
25	A20150	Belt roller (Type D)	2
26	B50090	Rubber roller (Type D)	1
27	A20360	Roller bushing (Type O)	2
28	CU-122A	Belt roller conductive piece (left)	1
29	B1023000	Rubber roller (Type O)	1
30	CU-123A	Belt roller conductive piece (right)	1
31	CU-113A	Bushing (Non hole drilling)	2
32	G10360	Idler spring with magnetic head	2
33	B3014B	Belt idler unit (700/777)	2
34	C1096B	Bill box fixed block	2
35	C16140	Rear retaining plate	1
36	PLA-4210	Heat-shrinkable tubing 10mm	2

L83(#) Main Unit Module

Figure 118.

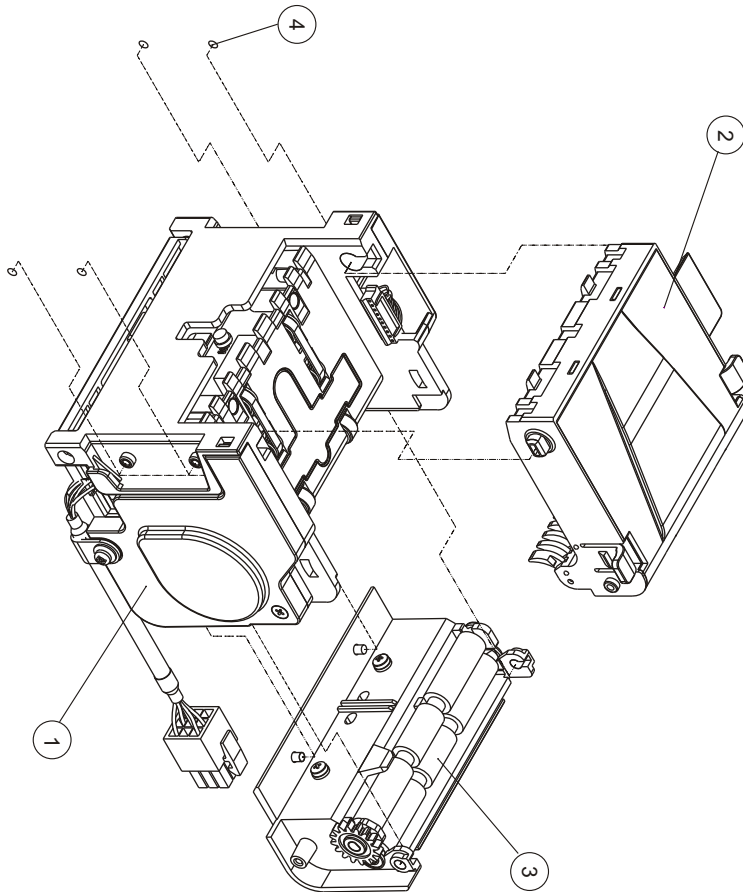

Order	Part number	Appellation	Quantity
1	3RBA-DWN23001	Lower base module (L83)	1
2	3RBA-UPX24000	Upper base module (L83)	1
3	3RBA-ROL12000	Roller mount module (L83)	1
4	3RBA-FAC35000	Face plate module (L83)	1

L83(#) Bezel Module

Figure 119.

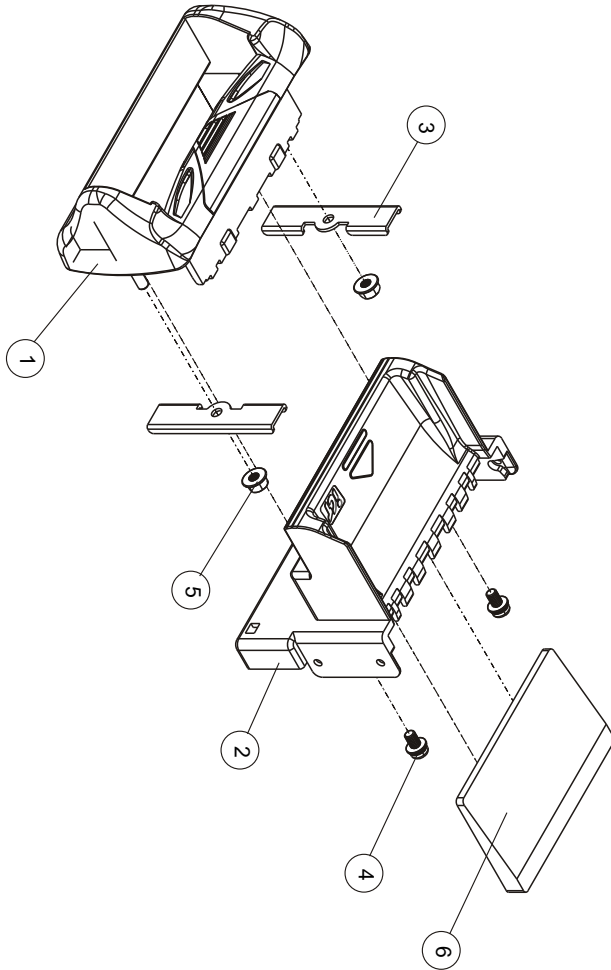

Order	Part number	Appellation	Quantity
1	A24470-R	Bezel	1
2	A24480-R	Bezel guidance plate (83mm)	1
3	C-18230-R	Bezel fixed piece	2
4	S40140	M4x8 Mechanical screw with washer (nickel plating)	2
5	S10100	M4 flange screw nut #10(N)	2
6	A24490-R	Guide light mirror (L83)	1

L83(#) Lower Base Module

Figure 120.

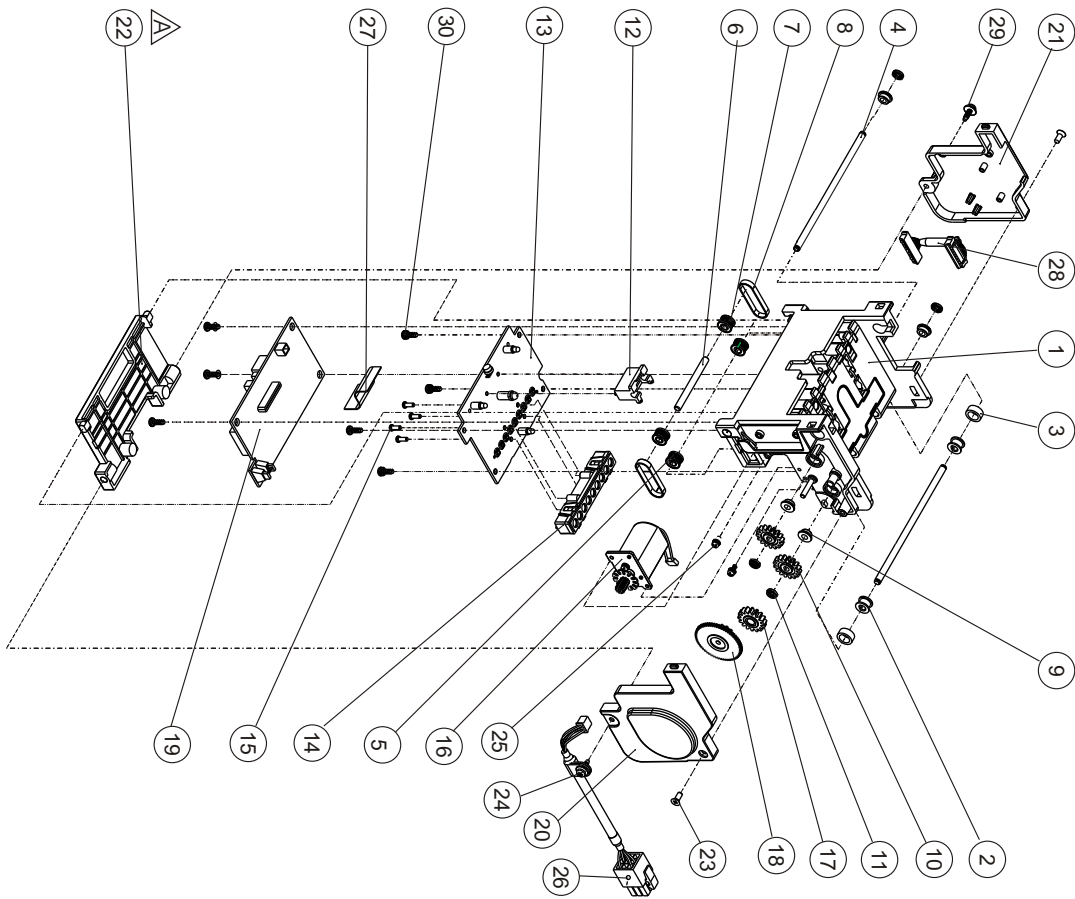

Note	Order	Part number	Appellation	Quantity
	1	A2442A00-R	Lower base assembly (83mm)	1
	2	A29170-R	Plate belt roller	2
	3	E50190-R	Plate belt (D7.0°D9.9°T4.0)	2
	4	B12400-R	Belt roller axle type D	2
	5	A20150-R	Belt roller type D	2
	6	B12320-R	Belt roller axle	1
	7	A20140-R	Belt roller type O	2
	8	E50180-R	Belt (34MxL-3.2)	2
	9	C16050-R	Axle bush-6	4
	10	F1038A-R	Gear (M1x16)	2
	11	A28780-R	M3 Plastic retaining ring	4
	12	A29190-R	Belt roller fixed stand	1
	13	AA324B**	LED PCB board	1
	14	3RBA-LEN01001	Optical lens unit (L70-circular hole)	1
	15	S20060	D2.3x6 Tapping screw (black-TP2)	4
	16	3RBA-MOT07000	Motor module (L70)	1
	17	F10140-R	Gear type O (M1-T16)	1
	18	F10370-R	Gear (M0.5xT60-M1.0xT12)	1
	19	AA324A**	CPU PCB board	1
	20	A24450-R	Right gear cover plate (L83)	1
	21	A2913A-R	Left side plate	1
	22	A2446A-R	Base plate (L83)	1
	23	S30760	D3x8 Flat counter-sunk head tapping screw (black zinc plating-TP2)	2
	24	J20730-R	Cable fixed ring (black) PC-3	1
	25	S20030	M2.5*5 Cup headed screw with washer (nickel plating)	2
	26		Outside power wire	1
	27		Clothing kit	1
	28		Sensor and LED board wiring	1
	29	S30890	M3*10 Mechanical black zinc plating screw with large washer	2
	30	S30750	3*8 Tapping black zinc plating screw TP2	7

L83(#) Upper Base Module

Figure 121.

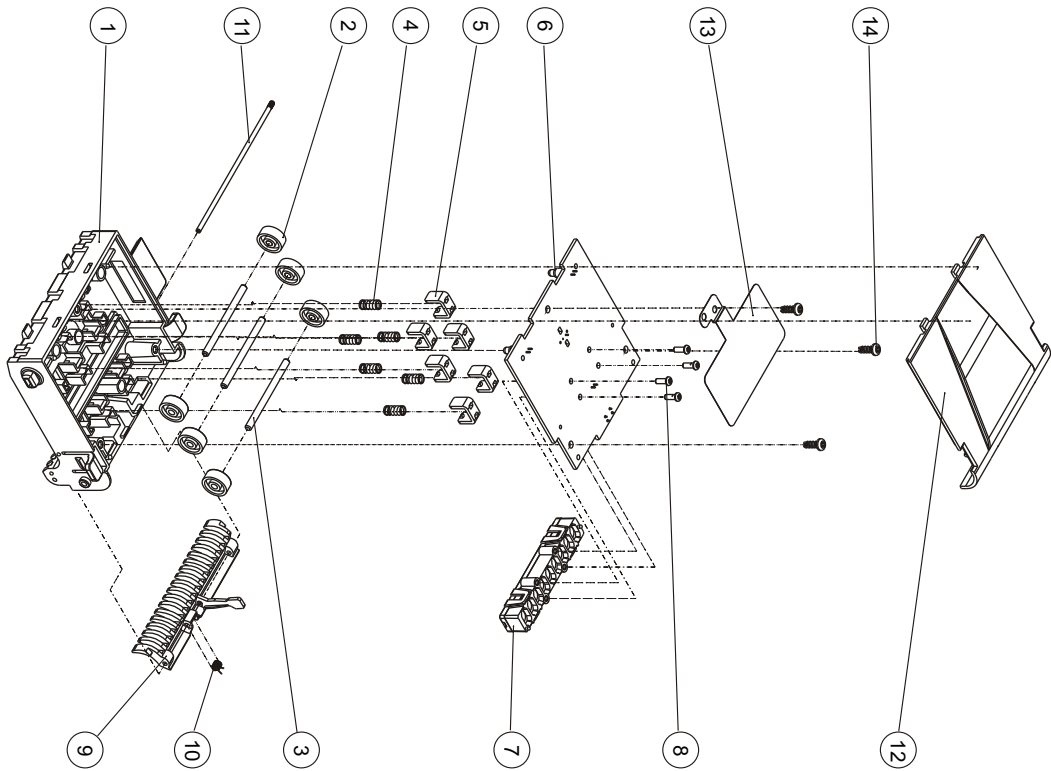

Order	Part number	Appellation	Quantity
1	A2441000-R	Upper base assembly (83mm)	1
2	A29560-R	Driving idler (white)	6
3	B12300-R	Idler axle	3
4	G10720-R	Idler pressure spring	6
5	A26840-R	Idler spring hook	6
6	AA324C**	Sensor PCB board	1
7	3RBA-LEN01001	Optical lens unit (70-circular hole)	1
8	S20060	D2.3x6 Tapping screw (black-TP2)	4
9	A24440-R	Security tooth (L83)	1
10	G10960-R	Security tooth spring	1
11	B12410-R	Security tooth shaft (L83)	1
12	A24430-R	Upper base cover plate (L83)	1
13	C18540-R	Conductive piece	1
14	S30750	3/8 Tapping black zinc plating screw TP2	3

L83(#) Roller Mount Module

Figure 122.

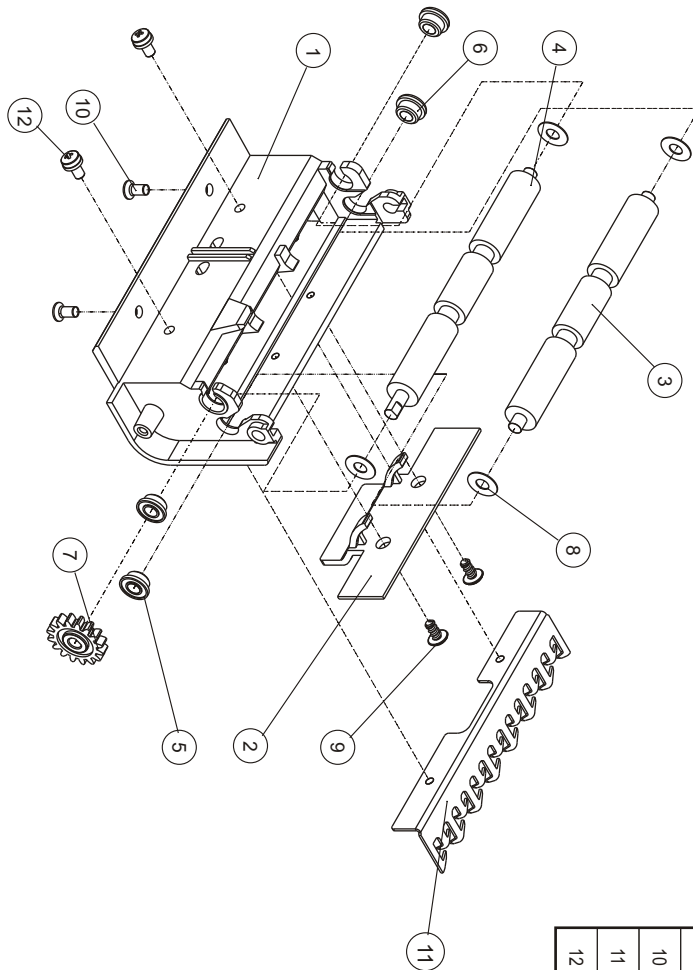

Order	Part number	Appellation	Quantity
1	A2433E-R	85 Roller fixed mount	1
2	A25350-R	Guidance reflected plate	1
3	B1119A-R	Rubber roller type O	1
4	B1120B-R	Rubber roller type D	2
5	CU-112B-R	Bushing (A)	2
6	CU-113A-R	Bushing (B)	4
7	F1038A-R	Gear (M1x16)	1
8	J20740-R	Nylon washer 4x9	1
9	S30580	3/6 Large flat head tapping black zinc plating screw TP2	2
10	S30590	M3*6 Flat counter-sunk head black zinc plating screw	2
11	C15080-R	Fishing security tooth (85UF)	2
12	S30460	M3*6 Mechanical black zinc plating screw with small washer	2

6-2. Circuit Board Overview

L70(#)/ L77(#)/ PL77

Figure 123.

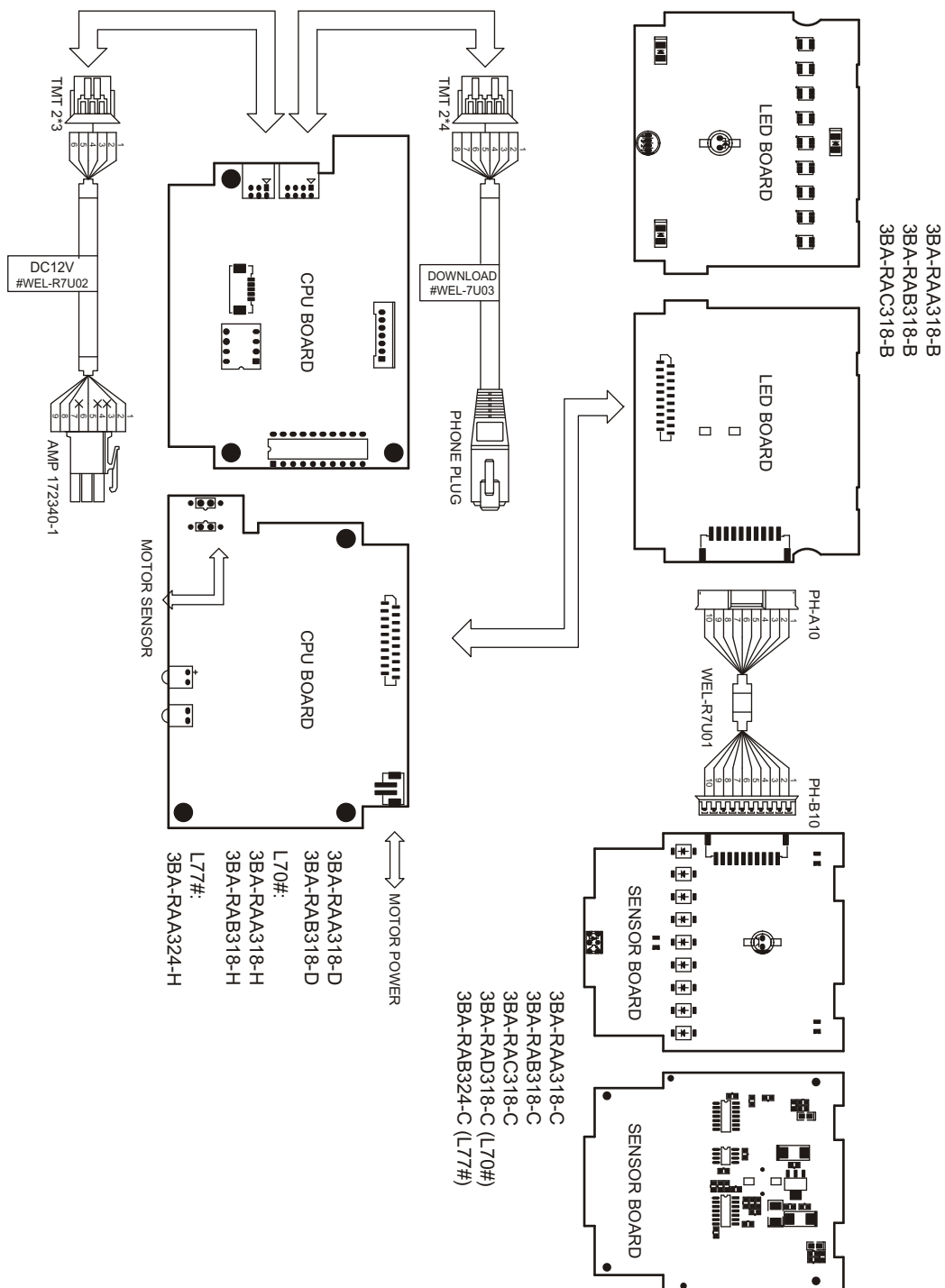
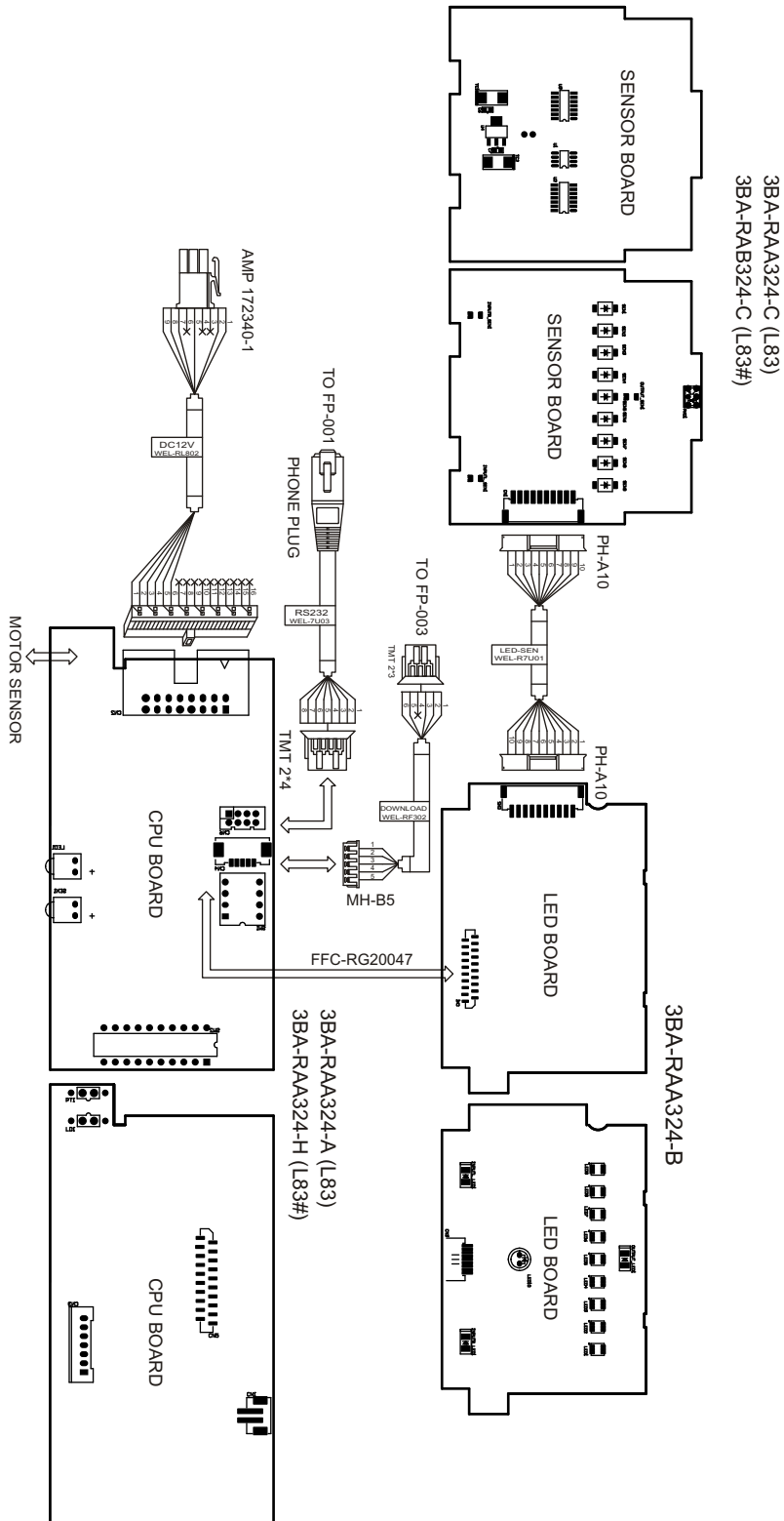

Figure 124.

L83(#)



ict *Taiwan*

International Currency Technologies Corporation

Ji-Hong Building, No 24, Alley 38, Lane 91, Nei-hu Rd., Sec. 1,
Taipei, Taiwan, R.O.C.

Tel: 886-2-2797-1238 Fax:886-2-2797-1634

sales@ictgroup.com.tw (For Sales)

rma@ictgroup.com.tw (For Customer service)

Website: www.ictgroup.com.tw



www.ictgroup.com.tw