

Operating Guide

FVF - PN 16, 25 / DN 15 - 300

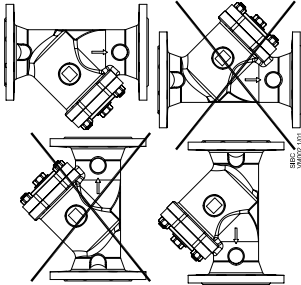

MAINTENANCE

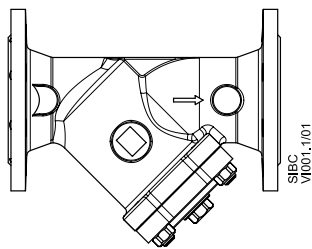

FVF (plug)

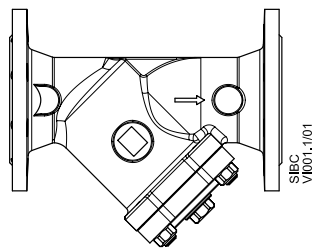

FVF (magnetic insert)

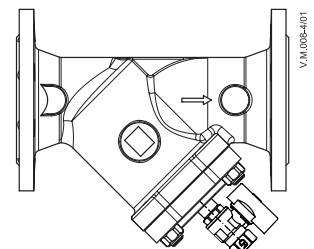

FVF (ball valve)

FVF (magnetic insert)

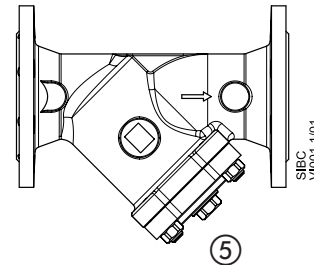
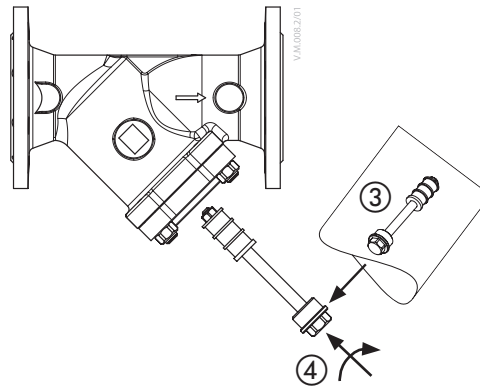
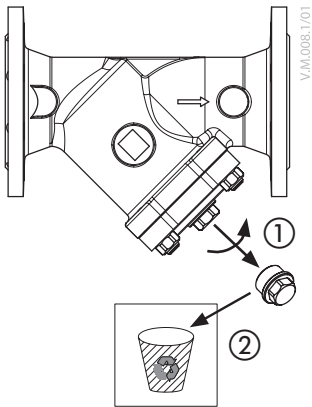

FVF (ball valve)

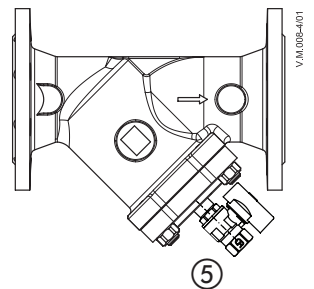
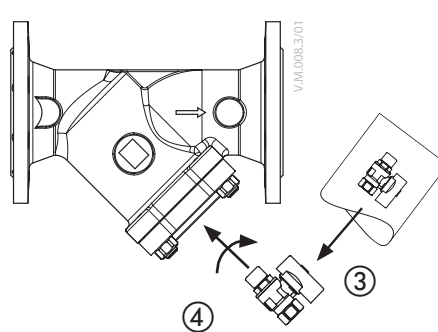
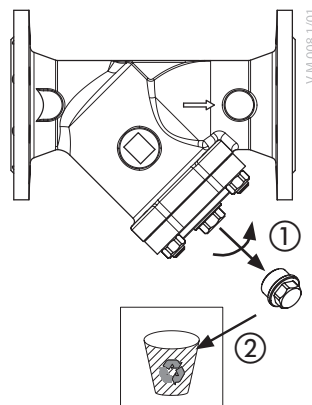

To prevent scalds during draining the draining ball valve must be equipped with drain hose, that leads to drainage system.

FVF

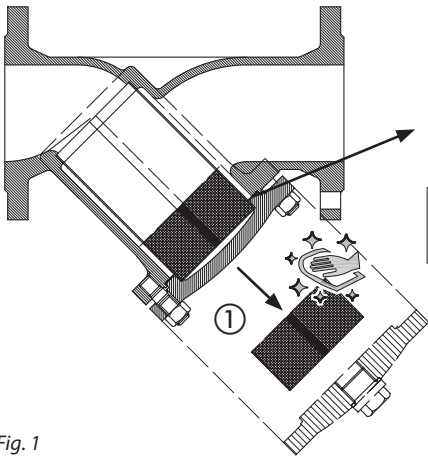

Fig. 1

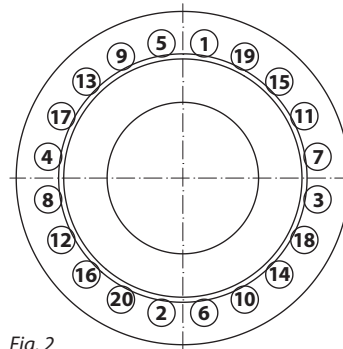
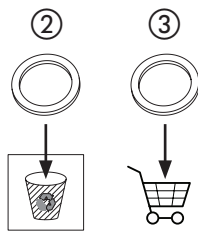
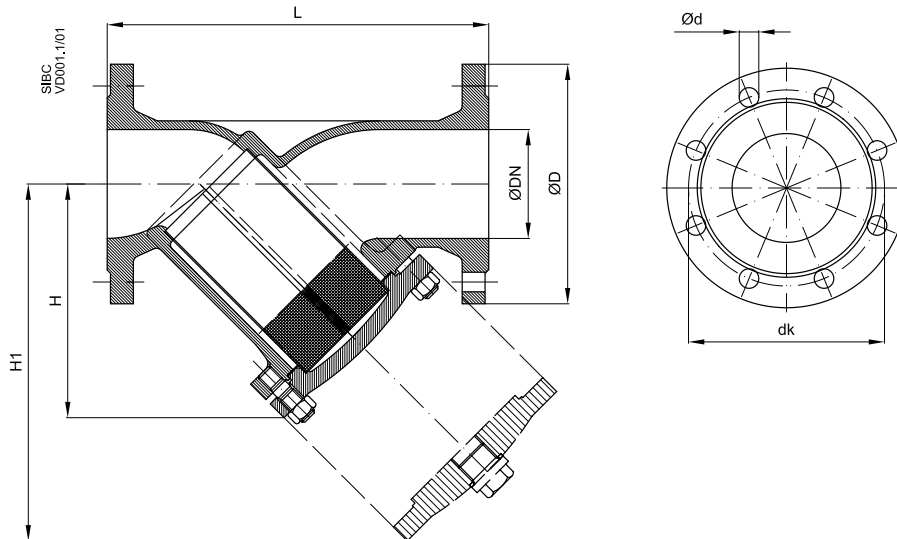

Fig. 2

DN	Tightning torque
15-32	35 Nm ± 5 Nm
40-65	35 Nm ± 10 Nm
80-200	100 Nm ± 10 Nm
250-300	170 Nm ± 15 Nm



When cleaning the mesh, screwing the cover should follow the sequence shown in Figure 2. Number of bolts depend of the strainer DN. Tightening torques in the table should be followed. The frequency of cleaning depends on the media quality and operating conditions.



DN	L	H	H ₁	PN 16			PN 25			Weight (kg)
				ØD	Ød	dk	ØD	Ød	dk	
mm										
15	130	75	115	95	14	65	95	14	65	2.2
20	150	75	115	105	14	75	105	14	75	3.3
25	160	90	135	115	14	85	115	14	85	3.8
32	180	90	135	140	19	100	140	19	100	5.0
40	200	110	170	150	19	110	150	19	110	6.5
50	230	120	190	165	19	125	165	19	125	8.5
65	290	140	220	185	19	145	185	19	145	12.0
80	310	165	265	200	19	160	200	19	160	16.6
100	350	220	340	220	19	180	235	23	190	25.0
125	400	260	410	250	19	210	270	28	220	39.0
150	480	300	475	285	23	240	300	28	250	61.0
200	600	360	580	340	23	295	360	28	310	109.0
250	730	470	680	405	28	355	425	31	370	162.0
300	850	560	820	460	28	410	485	31	430	280.0

Danfoss A/S

Climate Solutions • danfoss.com • +45 7488 2222

All information, including, but not limited to information on selection of product, its application or use, product design, weight, dimensions, capacity or any other technical data in product manuals, catalogues descriptions, advertisements, etc. and whether made available in writing, orally, electronically, online or via download, shall be considered informative, and is only binding if and to the extent, explicit reference is made in a quotation or order confirmation. Danfoss cannot accept any responsibility for possible errors in catalogues, brochures, videos and other material. Danfoss reserves the right to alter its products without notice. This also applies to products ordered but not delivered provided that such alterations can be made without changes to form, fit or function of the product.

All trademarks in this material are property of Danfoss A/S or Danfoss group companies. Danfoss and the Danfoss logo are trademarks of Danfoss A/S. All rights reserved.