

NO. 4E400S-2017-A0

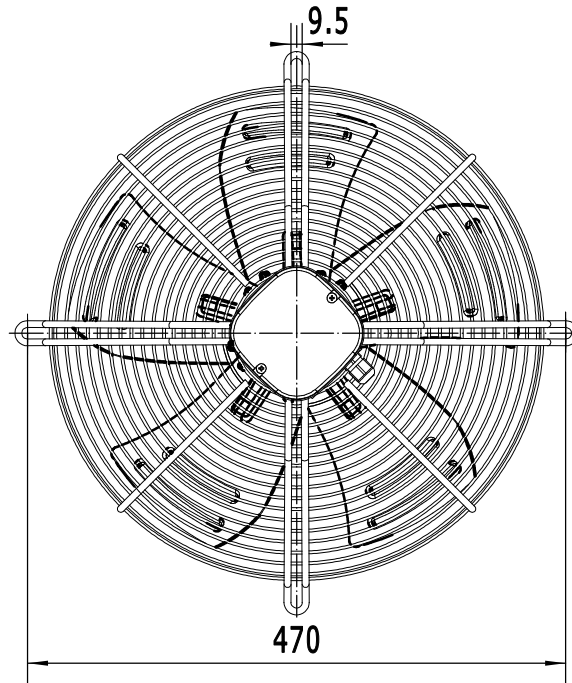

SPECIFICATION 规格说明
HANGZHOU WEIGUANG ELECTRONIC CO.,LTD.

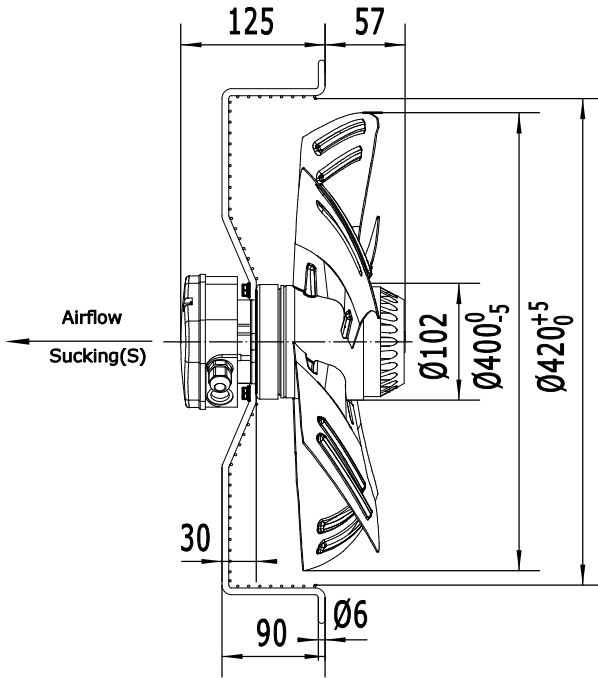

LABEL (铭牌):



WIRING DIAGRAM (接线图):

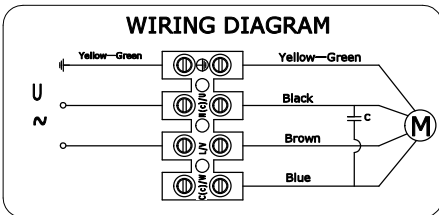

FLOW RATE CURVE (风量曲线):

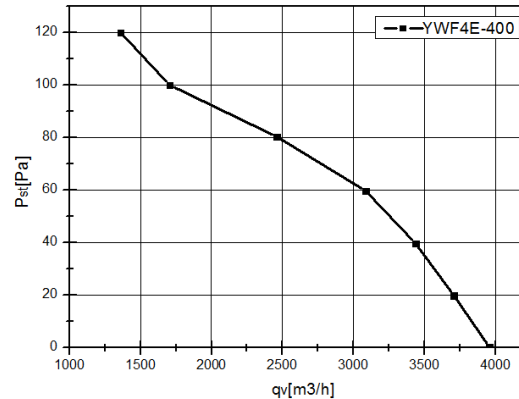

UNIT 类型	Axial fan motor 外转子轴流风机
MOTOR 电机型式	Single phase motor with capacitor
MOTOR TYPE 电机型号	YWF4E-400S-102/47-G
VOLTAGE 额定电压 (V)	220
FREQUENCY 频率 (Hz)	50
INPUT POWER 输入功率 (W)	180
CURRENT 电流 (A)	0.82
SPEED 转速 (r/min)	1380
AIR FLOW 20Pa 风量 (m³/h)	3700
NOISE 噪音 (dBA)	67
CAPACITOR 电容 (µF/450V)	6
ROTATION 旋转方向	CW ,looking into the end-shield 顺时针, 从端盖端方向看
INSULATION CLASS 绝缘等级	B
MOTOR PROTECTION 电机保护	Thermocontact 135±5℃ 热保护器
TEMPERATURE RISE 温升	75K max 运行温升不超过75K
TYPE OF PROTECTION 防护等级	IP44
OPERATING TYPE 工作定额	S1 连续工作制
AMBIENT TEMPERATURE 适用环境温度	-30℃ +60℃
BEARINGS 轴承型式	Ball bearings 滚珠轴承
MOUNTING TYPE 安装方式	Horizontal or Vertical 垂直或水平安装
ELECTRICAL CONNECTION 电源线	Lead wire Silikon 4G 0.50mm² ,Length 100mm in terminal box connected 接线盒(4芯0.5mm²线长100mm)
APPROVALS 认证标记	CCC、CE
NET WEIGHT/GROSS WEIGHT 净重/毛重	6.0/7.0kg
PACKING 包装	43.5*43.5*20cm

REV.	DESCRIPTION	APPROVED	DATE				SIGN	DATE	TITLE
							DRN. BY		YWF4E-400S-102/47-G
							CHD. BY		
							ENG. BY		
							APP. BY		
									PROJECTION
									A4
									SCALE
									SHEET: of