

NO. 2E300S-2017-A0

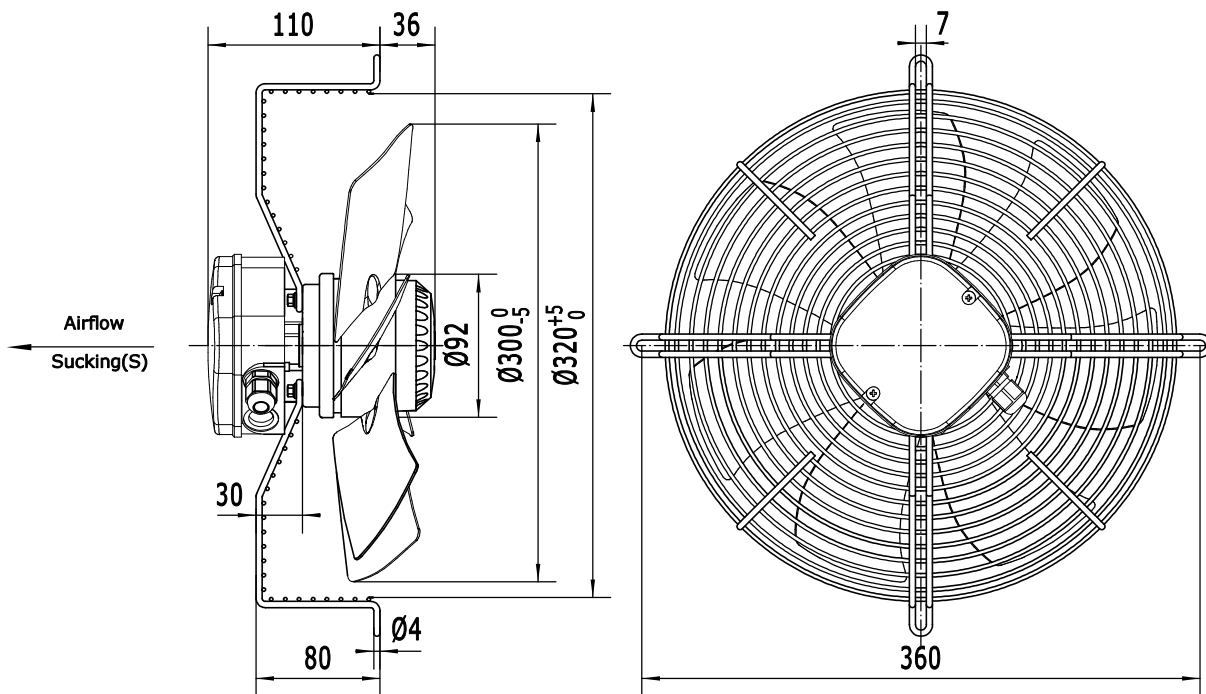

SPECIFICATION 规格说明  
HANGZHOU WEIGUANG ELECTRONIC CO.,LTD.



UNIT 类型	Axial fan motor 外转子轴流风机
MOTOR 电机型式	Single phase motor with capacitor
MOTOR TYPE 电机型号	YWF2E-300S-92/35-G
VOLTAGE 额定电压 (V)	220
FREQUENCY 频率 (Hz)	50
INPUT POWER 输入功率 (W)	145
CURRENT 电流 (A)	0.66
SPEED 转速 (r/min)	2300
AIR FLOW 20Pa 风量 (m³/h)	2200
NOISE 噪音 (dBA)	62
CAPACITOR 电容 (µF/450V)	4
ROTATION 旋转方向	CCW ,looking into the end-shield 逆时针, 从端盖端方向看
INSULATION CLASS 绝缘等级	B
MOTOR PROTECTION 电机保护	Thermocontact 135±5°C 热保护器
TEMPERATURE RISE 温升	75K max 运行温升不超过75K
TYPE OF PROTECTION 防护等级	IP44
OPERATING TYPE 工作定额	S1 连续工作制
AMBIENT TEMPERATURE 适用环境温度	-30°C +60°C
BEARINGS 轴承型式	Ball bearings 滚珠轴承
MOUNTING TYPE 安装方式	Horizontal or Vertical 垂直或水平安装
ELECTRICAL CONNECTION 电源线	Lead wire Silikon 4G 0.50mm² ,Length 100mm in terminal box connected 接线盒(4芯0.5mm²线长100mm)
APPROVALS 认证标记	CCC、CE
NET WEIGHT/GROSS WEIGHT 净重/毛重	3.0/4.0kg
PACKING 包装	34.0*34.0*18cm

LABEL (铭牌):



FLOW RATE CURVE (风量曲线):

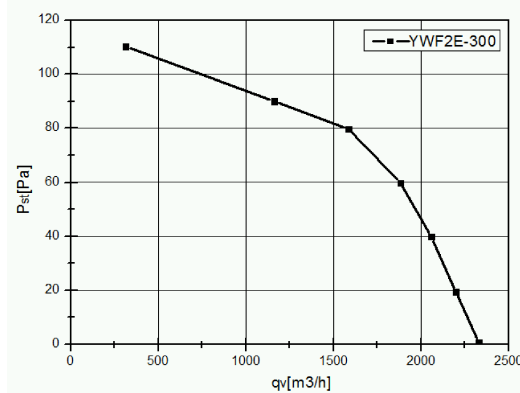

WIRING DIAGRAM (接线图):

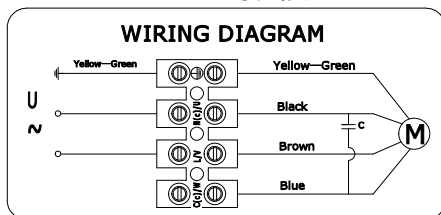

REV.	DESCRIPTION	APPROVED	DATE	DRN. BY	SIGN	DATE	TITLE
				CHD. BY			YWF2E-300S-92/35-G
				ENG. BY			PROJECTION
				APP. BY			A4 SCALE SHEET: of