



DYLLU

说明书材质要求：105g 有光铜版纸	说明书成品尺寸：105*143mm
第一：专色用6级防晒油墨	第二：特别注意： 1.印刷时看样请参考我司提供的实物样品颜色。不得偏色
	 Pantone cool gray 10C  Pantone 389C  Black (三色印刷)
折叠方式：风琴折 (20P以下 用风琴折) / 骑马钉(20P以上 用骑马钉) 特殊情况：16P/20P：风琴折 + 对折	备注：

特别注意：此页内容不印刷

风琴折 + 对折 页面顺序																																					
<p>16P 页面顺序</p> <table border="1"><tr><td>9</td><td>10</td><td>11</td><td>封面</td></tr><tr><td>12</td><td>13</td><td>14</td><td>封底</td></tr></table> <table border="1"><tr><td>1</td><td>2</td><td>3</td><td>4</td></tr><tr><td>5</td><td>6</td><td>7</td><td>8</td></tr></table>	9	10	11	封面	12	13	14	封底	1	2	3	4	5	6	7	8	<p>20P 页面顺序</p> <table border="1"><tr><td>11</td><td>12</td><td>13</td><td>14</td><td>封面</td></tr><tr><td>15</td><td>16</td><td>17</td><td>18</td><td>封底</td></tr></table> <table border="1"><tr><td>1</td><td>2</td><td>3</td><td>4</td><td>5</td></tr><tr><td>6</td><td>7</td><td>8</td><td>9</td><td>10</td></tr></table>	11	12	13	14	封面	15	16	17	18	封底	1	2	3	4	5	6	7	8	9	10
9	10	11	封面																																		
12	13	14	封底																																		
1	2	3	4																																		
5	6	7	8																																		
11	12	13	14	封面																																	
15	16	17	18	封底																																	
1	2	3	4	5																																	
6	7	8	9	10																																	

更改记录	1. 新设计				
	0125.D01	2025.1.13	LYD		
	版本号	日期	设计师		



PRODUCT MANUAL

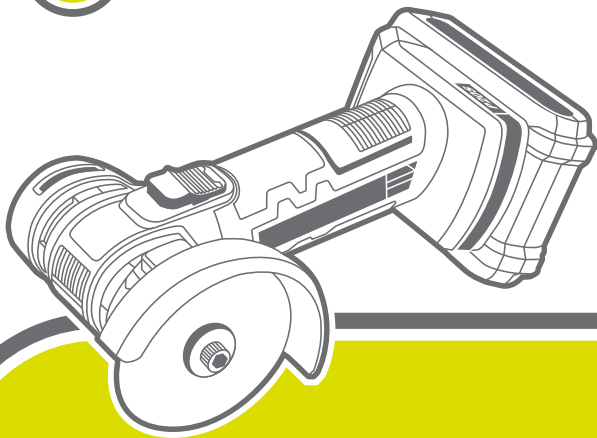

CORDLESS MINI CUT-OFF TOOL

DTLAP573 DTLAP573xy UDTLAP573xy
x(blank,1,2,3,4,5,6,7,8,9,E,S,A,M)
y(blank,-1,-2,-3,-4,-5,-6,-7,-8,-9,E,S,A,M)

DYLLU, discover your power

GENERAL POWER TOOL SAFETY WARNINGS

⚠ WARNING! Read all safety warnings, instructions, illustrations and specifications provided with this power tool. *Failure to follow all instructions listed below may result in electric shock, fire and/or serious injury.*

Save all warnings and instructions for future reference.

The term "power tool" in the warnings refers to your mains-operated (corded) power tool or battery-operated (cordless) power tool.

1) Work area safety

- a) **Keep work area clean and well lit.** *Cluttered or dark areas invite accidents.*
- b) **Do not operate power tools in explosive atmospheres, such as in the presence of flammable liquids, gases or dust.** *Power tools create sparks which may ignite the dust or fumes.*
- c) **Keep children and bystanders away while operating a power tool.** *Distractions can cause you to lose control.*

2) Electrical safety

- a) **Power tool plugs must match the outlet. Never modify the plug in any way. Do not use any adapter plugs with earthed (grounded) power tools.** *Unmodified plugs and matching outlets will reduce risk of electric shock.*
- b) **Avoid body contact with earthed or grounded surfaces, such as pipes, radiators, ranges and refrigerators.** *There is an increased risk of electric shock if your body is earthed or grounded.*
- c) **Do not expose power tools to rain or wet conditions.** *Water entering a power tool will increase the risk of electric shock.*
- d) **Do not abuse the cord. Never use the cord for carrying, pulling or unplugging the power tool. Keep cord away from heat, oil, sharp edges or moving parts.** *Damaged or entangled cords increase the risk of electric shock.*
- e) **When operating a power tool outdoors, use an extension cord suitable for outdoor use.** *Use of a cord suitable for outdoor use reduces the risk of electric shock.*
- f) **If operating a power tool in a damp location is unavoidable, use a residual current device (RCD) protected supply.** *Use of an RCD reduces the risk of electric shock.*

3) Personal safety

- a) **Stay alert, watch what you are doing and use common sense when operating a power tool. Do not use a power tool while you are tired or under the influence of drugs, alcohol or medication. A moment of inattention while operating power tools may result in serious personal injury.**
- b) **Use personal protective equipment. Always wear eye protection. Protective equipment such as a dust mask, non-skid safety shoes, hard hat or hearing protection used for appropriate conditions will reduce personal injuries.**
- c) **Prevent unintentional starting. Ensure the switch is in the off-position before connecting to power source and/or battery pack, picking up or carrying the tool. Carrying power tools with your finger on the switch or energising power tools that have the switch on invites accidents.**
- d) **Remove any adjusting key or wrench before turning the power tool on. A wrench or a key left attached to a rotating part of the power tool may result in personal injury.**
- e) **Do not overreach. Keep proper footing and balance at all times. This enables better control of the power tool in unexpected situations.**
- f) **Dress properly. Do not wear loose clothing or jewellery. Keep your hair and clothing away from moving parts. Loose clothes, jewellery or long hair can be caught in moving parts.**
- g) **If devices are provided for the connection of dust extraction and collection facilities, ensure these are connected and properly used. Use of dust collection can reduce dust-related hazards.**
- h) **Do not let familiarity gained from frequent use of tools allow you to become complacent and ignore tool safety principles. A careless action can cause severe injury within a fraction of a second.**

4) Power tool use and care

- a) **Do not force the power tool. Use the correct power tool for your application. The correct power tool will do the job better and safer at the rate for which it was designed.**
- b) **Do not use the power tool if the switch does not turn it on and off. Any power tool that cannot be controlled with the switch is dangerous and must be repaired.**
- c) **Disconnect the plug from the power source and/or remove the battery**

pack, if detachable, from the power tool before making any adjustments, changing accessories, or storing power tools. *Such preventive safety measures reduce the risk of starting the power tool accidentally.*

- d) **Store idle power tools out of the reach of children and do not allow persons unfamiliar with the power tool or these instructions to operate the power tool.** *Power tools are dangerous in the hands of untrained users.*
- e) **Maintain power tools and accessories. Check for misalignment or binding of moving parts, breakage of parts and any other condition that may affect the power tool's operation. If damaged, have the power tool repaired before use.** *Many accidents are caused by poorly maintained power tools.*
- f) **Keep cutting tools sharp and clean.** *Properly maintained cutting tools with sharp cutting edges are less likely to bind and are easier to control.*
- g) **Use the power tool, accessories and tool bits etc. in accordance with these instructions, taking into account the working conditions and the work to be performed. Use of the power tool for operations different from those intended could result in a hazardous situation.**
- h) **Keep handles and grasping surfaces dry, clean and free from oil and grease.** *Slippery handles and grasping surfaces do not allow for safe handling and control of the tool in unexpected situations.*

5) Battery tool use and care

- a) **Recharge only with the charger specified by the manufacturer.** *A charger that is suitable for one type of battery pack may create a risk of fire when used with another battery pack.*
- b) **Use power tools only with specifically designated battery packs.** *Use of any other battery packs may create a risk of injury and fire.*
- c) **When battery pack is not in use, keep it away from other metal objects, like paper clips, coins, keys, nails, screws or other small metal objects, that can make a connection from one terminal to another. Shorting the battery terminals together may cause burns or a fire.**
- d) **Under abusive conditions, liquid may be ejected from the battery; avoid contact. If contact accidentally occurs, flush with water. If liquid contacts eyes, additionally seek medical help. Liquid ejected from the battery may cause irritation or burns.**

- e) **Do not use a battery pack or tool that is damaged or modified.** *Damaged or modified batteries may exhibit unpredictable behaviour resulting in fire, explosion or risk of injury.*
- f) **Do not expose a battery pack or tool to fire or excessive temperature.** *Exposure to fire or temperature above 130 °C may cause explosion.*
- g) **Follow all charging instructions and do not charge the battery pack or tool outside the temperature range specified in the instructions.** *Charging improperly or at temperatures outside the specified range may damage the battery and increase the risk of fire.*

6) Service

- a) **Have your power tool serviced by a qualified repair person using only identical replacement parts.** *This will ensure that the safety of the power tool is maintained.*
- b) **Never service damaged battery packs.** *Service of battery packs should only be performed by the manufacturer or authorized service providers*

BATTERY TOOL SAFETY WARNINGS

Save these instructions.

⚠ CAUTION!

Only use genuine original batteries. *Use of non-genuine batteries, or batteries that have been altered, may result in the battery bursting causing fires, personal injury, and damage. It will also void the warranty for the tool and charged and dark areas invite accidents.*

⚠ WARNING!

- a) **Do not dismantle, open or shred secondary cells or batteries.**
- b) **Keep batteries out of the reach of children.** *Battery usage by children should be supervised. Especially keep small batteries out of reach of small children.*
- c) **Seek medical advice immediately if a cell or a battery has been swallowed.**
- d) **Do not expose cells or batteries to heat or fire.** *Avoid storage in direct sunlight.*
- e) **Do not short-circuit a cell or a battery.** *Do not store cells or batteries haphazardly in a box or drawer where they may short-circuit each other or be short-circuited by other metal objects.*
- f) **Do not remove a cell or battery from its original packaging until required for use.**
- g) **Do not subject cells or batteries to mechanical shock.**
- h) **In the event of a cell leaking, do not allow the liquid to come in contact with the skin or eyes.** *If contact has been made, wash the affected area with copious amounts of water and seek medical advice.*
- i) **Do not use any charger other than that specifically provided for use with the equipment.**
- j) **Observe the plus (+) and minus (-) marks on the cell, battery and equipment and ensure correct use.**
- k) **Do not use any cell or battery which is not designed for use with the equipment.**
- l) **Do not mix cells of different manufacture, capacity, size or type within a device.**
- m) **Always purchase the battery recommended by the device manufacturer for the equipment.**
- n) **Keep cells and batteries clean and dry.**
- o) **Wipe the cell or battery terminals with a clean dry cloth if they become**

dirty.

- p) **Secondary cells and batteries need to be charged before use.** *Always use the correct charger and refer to the manufacturer's instructions or equipment manual for proper charging instructions.*
- q) **Do not leave a battery on prolonged charge when not in use.**
- r) **After extended periods of storage, it may be necessary to charge and discharge the cells or batteries times to obtain maximum performance.**
- s) **Retain the original product literature for future reference.**
- t) **Use the cell or battery only in the application for which it was intended.**
- u) **When possible, remove the battery from the equipment when not in use.**
- v) **Dispose of properly.**

Tips for maintaining maximum battery life

- a) **Charge the battery cartridge before completely discharged.** *Always stop tool operation and charge the battery cartridge when you notice less tool power.*
- b) **Never recharge a fully charged battery cartridge.** *Overcharging shortens the battery service life.*
- c) **Charge the battery cartridge with room temperature at 10°C-40°C (50°F-104°F).** *Let a hot battery cartridge cool down before charging it.*
- d) **Charge the battery cartridge if you do not use it for a long period (more than six months).**

Important safety instructions for battery cartridge

1. **Before using battery cartridge, read all instructions and cautionary markings on battery charger, battery, and) product using battery.**
2. **Do not disassemble battery cartridge.**
3. **If operating time has become excessively shorter, stop operating immediately.** *It may result in a risk of overheating, possible burns and even an explosion.*
4. **If electrolyte gets into your eyes, rinse them out with clear water and seek medical attention right away.** *It may result in loss of your eyesight.*
5. **Do not short the battery cartridge:**
 - *Do not touch the terminals with any conductive material.*
 - *Avoid storing battery cartridge in a container with other metal objects such as nails, coins, etc.*

- *Do not expose battery cartridge to water or rain.*
 - *A battery short can cause a large current flow, overheating, possible burns and even a breakdown.*
6. **Do not store the tool and battery cartridge in locations where the temperature may reach or exceed 50°C (122°F).**
 7. **Do not incinerate the battery cartridge even if it is severely damaged or is completely worn out.** *The battery cartridge can explode in a fire.*
 8. **Be careful not to drop or strike battery.**
 9. **Do not use a damaged battery.**
 10. **Follow your local regulations relating to disposal of battery.**

Tool / battery protection system

The tool is equipped with a tool/battery protection system. This system automatically cuts off power to the motor to extend tool and battery life. The tool will automatically stop during operation if the tool or battery is placed under one of the following conditions:

Overload protection

When the battery is operated in a manner that causes it to draw an abnormally high current, the tool automatically stops without any indication. In this situation, turn the tool off and stop the application that caused the tool to become overloaded. Then turn the tool on to restart.

Overheat protection

When the tool/battery is overheated, the tool stops automatically. In this situation, let the tool/battery cool before turning the tool on again.

Transportation

Batteries comply with all applicable shipping regulations as prescribed by industry and legal standards (for more information, check with the manufacturer).

Transporting batteries can possibly cause fire if the battery terminals inadvertently come in contact with conductive materials. When transporting batteries, make sure that the battery terminals are protected and well insulated from materials that could contact them and cause a short circuit.

The information provided in this section of the manual is provided in good faith and believed to be accurate at the time the document was created. However, no warranty, expressed or implied, is given. It is the buyer's responsibility to ensure

that its activities comply with the applicable regulations.

Protecting the environment

Separate collection. This product must not be disposed of with normal household waste.

Should you find one day that your product needs replacement, or if it is of no further use to you, do not dispose of it with household waste. Make this product available for separate collection.

Separate collection of used products and packaging allows materials to be recycled and used again. Re-use of recycled materials helps prevent environmental pollution and reduces the demand for raw materials.











Local regulations may provide for separate collection of electrical products from the household, at municipal waste sites or by the retailer when you purchase a new product.

Rechargeable battery pack

This long-life battery pack must be recharged when it fails to produce sufficient power on jobs which were easily done before. At the end of its technical life, discard it with due care for our environment:

- Run the battery pack down completely, then remove it from the tool.
- Lithium-ion cells are recyclable. Take them to your dealer or a local recycling station. The collected battery packs will be recycled or disposed of properly.

THE SYMBOLS IN INSTRUCTION MANUAL

	<p>Double insulated for additional protection</p>
	<p>Read the instruction manual before using.</p>
	<p>CE conformity.</p>
	<p>Safety alert. Please only use the accessories supported by the manufacturer.</p>
	<p>Wear safety glasses, hearing protection and dust mask.</p>
	<p>Waste electrical products should not be disposed of with household waste. Please recycle where facilities exist. Check with your Local Authority or retailer for recycling advice.</p>
	<p>Charging the battery only below 40°C</p>
	<p>Always recycle batteries.</p>
	<p>Do not destroy battery by fire.</p>
	<p>Do not expose battery to water</p>

ADDITIONAL SAFETY WARNING

Angle grinder safety warning

Safety instructions for all operations

Safety warnings common for grinding, sanding, wire brushing, polishing or cutting-off operations:

- a) **This power tool is intended to function as a grinder, sander, wire brush, polisher or cut-off tool. Read all safety warnings, instructions, illustrations and specifications provided with this power tool. *Failure to follow all instructions listed below may result in electric shock, fire and/or serious injury.***
- b) **Operations such as grinding, sanding, wire brushing, polishing or cutting-off are not recommended to be performed with this power tool. *Operations for which the power tool was not designed may create a hazard and cause personal injury.***
- c) **Do not convert this power tool to operate in a way which is not specifically designed and specified by the tool manufacturer. *Such a conversion may result in a loss of control and cause serious personal injury.***
- d) **Do not use accessories which are not specifically designed and recommended by the tool manufacturer. *Just because the accessory can be attached to your power tool, it does not assure safe operation.***
- e) **The rated speed of the accessory must be at least equal to the maximum speed marked on the power tool. *Accessories running faster than their rated speed can break and fly apart.***
- f) **The outside diameter and the thickness of your accessory must be within the capacity rating of your power tool. *Incorrectly sized accessories cannot be adequately guarded or controlled.***
- g) **The dimensions of the accessory mounting must fit the dimensions of the mounting hardware of the power tool. *Accessories that do not match the mounting hardware of the power tool will run out of balance, vibrate excessively and may cause loss of control.***
- h) **Do not use a damaged accessory. Before each use inspect the accessory such as abrasive wheels for chips and cracks, backing pad for cracks, tear or excess wear, wire brush for loose or cracked wires. If power tool or accessory is dropped, inspect for damage or install an undamaged accessory. After inspecting and installing an accessory, position yourself**

and bystanders away from the plane of the rotating accessory and run the power tool at maximum no-load speed for one minute. *Damaged accessories will normally break apart during this test time.*

- i) **Wear personal protective equipment.** Depending on application, use face shield, safety goggles or safety glasses. As appropriate, wear dust mask, hearing protectors, gloves and workshop apron capable of stopping small abrasive or workpiece fragments. *The eye protection must be capable of stopping flying debris generated by various operations. The dust mask or respirator must be capable of filtrating particles generated by your operation. Prolonged exposure to high intensity noise may cause hearing loss.*
- j) **Keep bystanders a safe distance away from work area.** Anyone entering the work area must wear personal protective equipment. *Fragments of workpiece or of a broken accessory may fly away and cause injury beyond immediate area of operation.*
- k) **Hold the power tool by insulated gripping surfaces only, when performing an operation where the cutting accessory may contact hidden wiring or its own cord.** *Cutting accessory contacting a “live” wire may make exposed metal parts of the power tool “live” and could give the operator an electric shock.*
- l) **Position the cord clear of the spinning accessory.** *If you lose control, the cord may be cut or snagged and your hand or arm may be pulled into the spinning accessory.*
- m) **Never lay the power tool down until the accessory has come to a complete stop.** *The spinning accessory may grab the surface and pull the power tool out of your control.*
- n) **Do not run the power tool while carrying it at your side.** *Accidental contact with the spinning accessory could snag your clothing, pulling the accessory into your body.*
- o) **Regularly clean the power tool’s air vents.** *The motor’s fan will draw the dust inside the housing and excessive accumulation of powdered metal may cause electrical hazards.*
- p) **Do not operate the power tool near flammable materials.** *Sparks could ignite these materials.*
- q) **Do not use accessories that require liquid coolants.** *Using water or other liquid coolants may result in electrocution or shock.*

Further safety instructions for all operations

Kickback and related warnings:

Kickback is a sudden reaction to a pinched or snagged rotating wheel, backing pad, brush or any other accessory. Pinching or snagging causes rapid stalling of the rotating accessory which in turn causes the uncontrolled power tool to be forced in the direction opposite of the accessory's rotation at the point of the binding.

For example, if an abrasive wheel is snagged or pinched by the workpiece, the edge of the wheel that is entering into the pinch point can dig into the surface of the material causing the wheel to climb out or kick out. The wheel may either jump toward or away from the operator, depending on direction of the wheel's movement at the point of pinching. Abrasive wheels may also break under these conditions.

Kickback is the result of power tool misuse and/or incorrect operating procedures or conditions and can be avoided by taking proper precautions as given below.

- a) **Maintain a firm grip on the power tool and position your body and arm to allow you to resist kickback forces. Always use auxiliary handle, if provided, for maximum control over kickback or torque reaction during start-up.** *The operator can control torque reactions or kickback forces, if proper precautions are taken.*
- b) **Never place your hand near the rotating accessory.** *Accessory may kickback over your hand.*
- c) **Do not position your body in the area where power tool will move if kickback occurs.** *Kickback will propel the tool in direction opposite to the wheel's movement at the point of snagging.*
- d) **Use special care when working corners, sharp edges etc. Avoid bouncing and snagging the accessory.** *Corners, sharp edges or bouncing have a tendency to snag the rotating accessory and cause loss of control or kickback.*
- e) **Do not attach a saw chain woodcarving blade, segmented diamond wheel with a peripheral gap greater than 10 mm or toothed saw blade.** *Such blades create frequent kickback and loss of control.*

Additional safety instructions for grinding and cutting-off operations

Safety warnings specific for grinding and abrasive cutting-off operations:

- a) **Use only wheel types that are recommended for your power tool and the specific guard designed for the selected wheel.** *Wheels for which the power tool was not designed cannot be adequately guarded and are unsafe.*

- b) **The grinding surface of center depressed wheels must be mounted below the plane of the guard lip.** *An improperly mounted wheel that projects through the plane of the guard lip cannot be adequately protected.*
- c) **The guard must be securely attached to the power tool and positioned for maximum safety, so the least amount of wheel is exposed towards the operator.** *The guard helps to protect the operator from broken wheel fragments, accidental contact with wheel and sparks that could ignite clothing.*
- d) **Wheels must be used only for recommended applications. For example: do not grind with the side of cut-off wheel.** *Abrasive cut-off wheels are intended for peripheral grinding, side forces applied to these wheels may cause them to shatter.*
- e) **Always use undamaged wheel flanges that are of correct size and shape for your selected wheel.** *Proper wheel flanges support the wheel thus reducing the possibility of wheel breakage. Flanges for cut-off wheels may be different from grinding wheel flanges.*
- f) **Do not use worn down wheels from larger power tools.** *Wheel intended for larger power tool is not suitable for the higher speed of a smaller tool and may burst.*
- g) **When using dual purpose wheels always use the correct guard for the application being performed.** *Failure to use the correct guard may not provide the desired level of guarding, which could lead to serious injury.*

Additional safety instructions for cutting-off operations

Additional safety warnings specific for cutting-off operations:

- a) **Do not “jam” the cut-off wheel or apply excessive pressure. Do not attempt to make an excessive depth of cut.** *Overstressing the wheel increases the loading and susceptibility to twisting or binding of the wheel in the cut and the possibility of kickback or wheel breakage.*
- b) **Do not position your body in line with and behind the rotating wheel.** *When the wheel, at the point of operation, is moving away from your body, the possible kickback may propel the spinning wheel and the power tool directly at you.*
- c) **When wheel is binding or when interrupting a cut for any reason, switch off the power tool and hold the power tool motionless until the wheel comes to a complete stop. Never attempt to remove the cut-off wheel**

from the cut while the wheel is in motion otherwise kickback may occur. Investigate and take corrective action to eliminate the cause of wheel binding.

- d) **Do not restart the cutting operation in the workpiece. Let the wheel reach full speed and carefully re-enter the cut.** *The wheel may bind, walk up or kickback if the power tool is restarted in the workpiece.*
- e) **Support panels or any oversized workpiece to minimize the risk of wheel pinching and kickback.** *Large workpieces tend to sag under their own weight. Supports must be placed under the workpiece near the line of cut and near the edge of the workpiece on both sides of the wheel.*
- f) **Use extra caution when making a “pocket cut” into existing walls or other blind areas.** *The protruding wheel may cut gas or water pipes, electrical wiring or objects that can cause kickback.*
- g) **Do not attempt to do curved cutting.** *Overstressing the wheel increases the loading and susceptibility to twisting or binding of the wheel in the cut and the possibility of kickback or wheel breakage, which can lead to serious injury.*

Additional safety instructions for sanding operations

Safety warnings specific for sanding operations:

- a) **Use proper sized sanding disc paper. Follow manufacturers recommendations, when selecting sanding paper.** *Larger sanding paper extending too far beyond the sanding pad presents a laceration hazard and may cause snagging, tearing of the disc or kickback.*

Additional safety instructions for polishing operations

Safety warnings specific for polishing operations:

- a) **Do not allow any loose portion of the polishing bonnet or its attachment strings to spin freely. Tuck away or trim any loose attachment strings.** *Loose and spinning attachment strings can entangle your fingers or snag on the workpiece.*

Additional safety instructions for wire brushing operations

Safety warnings specific for wire brushing operations:

- a) **Be aware that wire bristles are thrown by the brush even during ordinary operation. Do not overstress the wires by applying excessive load to the brush.** *The wire bristles can easily penetrate light clothing and/or skin.*

- b) **If the use of a guard is recommended for wire brushing, do not allow any interference of the wire wheel or brush with the guard.** *Wire wheel or brush may expand in diameter due to work load and centrifugal forces.*

RESIDUAL RISKS

Even when the power tool is used as prescribed it is not possible to eliminate all residual risk factors. The following hazards may arise in connection with the power tool's construction and design:

- a) Health defects resulting from vibration emission if the power tool is being used over longer period of time or not adequately managed and properly maintained.
- b) Injuries and damage to property to due to broken accessories that are suddenly dashed.

WARNING!

This power tool produces an electromagnetic field during operation. This field may under some circumstances interfere with active or passive medical implants. To reduce the risk of serious or fatal injury, we recommend persons with medical implants to consult their physician and the medical implant manufacturer before operating this power tool.

INTENDED USE

This power tool is intended to function as a grinder, sander, wire brush, polisher, carving or cut-off tool.

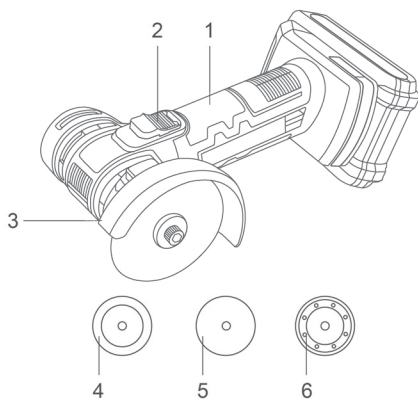
SPECIFICATIONS

- | | |
|------------------------|--------------------------|
| 1. Hand grip area | 4. Metal cutting disc |
| 2. On/off switch | 5. Abrasive cutting disc |
| 3. Spindle lock button | 6. Grinding disc |

Technical specifications

Model No.	DTLAP573, DTLAP573xy, UDTLAP573xy
Voltage	20V
No-load speed	19500/min
Disc diameter	76mm (3")
Spindle thread	M6
Disc bore	10mm

Model No. Note: x (blank, 1,2,3,4,5,6,7,8,9,E,S,A,M); y (blank, -1,-2,-3,-4,-5,-6,-7,-8,-9,E,S,A,M)

- Due to our continuing program of research and development, the specifications herein are subject to change without notice.
- Specifications and battery cartridge may differ from country to country.

⚠ WARNING!

Only use original battery pack and battery charger as below for this power tool:

Product	Battery pack		
Model No.	Type	Rated voltage	Rated capacity
DTLBP515 DTLBP515xy	Lithium-Ion	18.5V d.c., 20V Max	1.5Ah
DTLBP520 DTLBP520xy			2.0Ah
DTLBP530 DTLBP530xy			3.0Ah
DTLBP540 DTLBP540xy			4.0Ah
DTLBP550 DTLBP550xy			5.0Ah

Model No. NOTE: x (blank, 1,2,3,4,5,6,7,8,9,E,S,A,M); y (blank, -1,-2,-3,-4,-5,-6,-7,-8,-9,E,S,A,M)

Product	Battery pack charger			
Model No.	Input power	Input voltage	Output rated voltage	Output rated current
DTFCP518 DTFCP518xy	45W	220-240V ~50/60Hz	20V d.c.	1.8A
UDTFCP518 UDTFCP518xy		110-120V ~50/60Hz		
DTFCP540 DTFCP540xy	105W	220-240V ~50/60Hz	20V d.c.	4A
UDTFCP540 UDTFCP540xy		110-120V ~50/60Hz		

Model No. NOTE: x (blank, 1,2,3,4,5,6,7,8,9,E,S,A,M); y (blank, -1,-2,-3,-4,-5,-6,-7,-8,-9,E,S,A,M)

OPERATION PICTURE

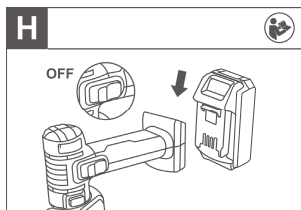
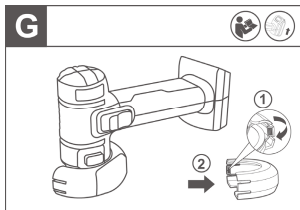
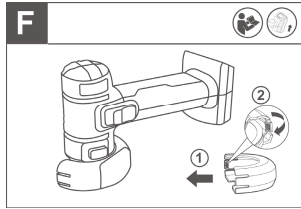
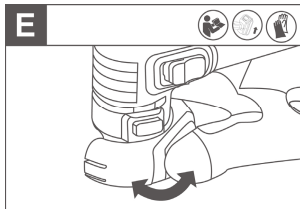
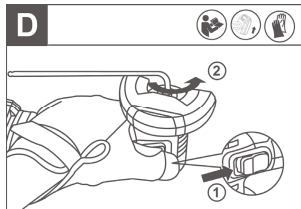
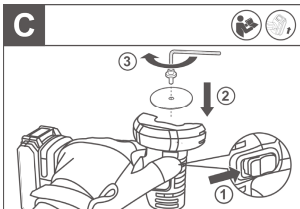
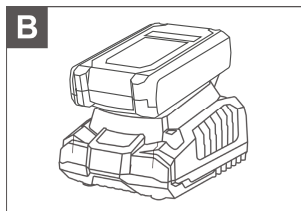
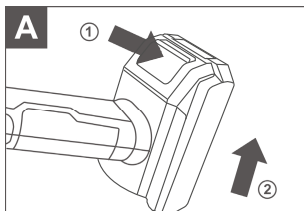

OPERATION PICTURE

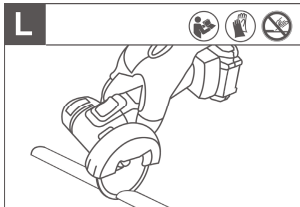
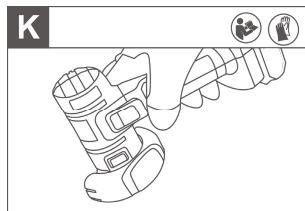
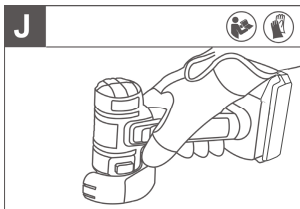
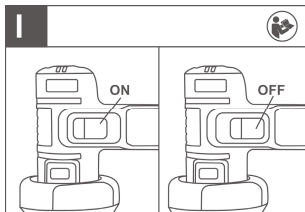

OPERATION

CAUTION

Always be sure that the tool is switched off and the battery cartridge is removed before adjusting or checking function on the tool.

Removing battery cartridge (see Figure A)

CAUTION

- Always switch off the tool before installing or removing of the battery cartridge.
- Hold the tool and the battery cartridge firmly when installing or removing battery cartridge. Failure to hold the tool and the battery cartridge firmly may cause them to slip off your hands and result in damage to the tool and battery cartridge and a personal injury.

To remove the battery cartridge, slide it from the tool while sliding the button on the front of the cartridge.

To install the battery cartridge, align the tongue on the battery cartridge with the groove in the housing and slip it into place. Insert it all the way until it locks in place with a little click. If you can see the red indicator on the upper side of the button, it is not locked completely.

CAUTION

- Always install the battery cartridge fully until the red indicator cannot be seen. If not, it may accidentally fall out of the tool, causing injury to you or someone around you.
- Do not install the battery cartridge forcibly. If the cartridge does not slide in easily, it is not being inserted correctly.

CAUTION

- Before installing the battery cartridge into the tool, always check to see that the slide switch actuates properly and returns to the "OFF" position when the rear of the slide switch is depressed.
- Switch can be locked in "ON" position for ease of operator comfort during extended use. Apply caution when locking tool in "ON" position and maintain firm grasp on tool.

Charging the Battery Pack (see Figure B)

Lock the spindle and assembling metal cutting disc/abrasive cutting disc / grinding disc (see Figure C)

Lock the spindle and removing metal cutting disc/abrasive cutting disc / grinding disc (see Figure D)

Adjusting Wheel Guard for grinding/ cutting (see Figure E, F, G)

Installing the Battery Pack (see Figure H)

Using On/Off Switch (see Figure I)

Hand grip areas (see Figure J)

Rough Grinding (see Figure K)

Cutting (see Figure L)

MAINTENANCE&MALFUNCTIONS

Possible malfunctions and methods of their eliminations

Malfunction	Probable causes	Actions
When the machine is turned on, the electric motor does not work.	<ul style="list-style-type: none"> ● Switch failure ● The power cord or wiring is broken, power cord plug malfunction; ● No brush contact with the collector; ● Wear/damage of brushes 	Disconnect the machine from the mains and contact a qualified specialist.
Formation of a circular fire on the collector	<ul style="list-style-type: none"> ● Brush wear/damage of the brush holder; ● Malfunction in the armature coil 	Disconnect the machine from the mains and contact a qualified specialist. Please don't repair the machine by your own.
When working, smoke or the smell of burning insulation appears from the ventilation openings.	<ul style="list-style-type: none"> ● Malfunction in the electric motor coil; ● Malfunction of the electrical part of the tool. 	
Increased noise in the gearbox	<ul style="list-style-type: none"> ● Wear/breakage of gears or bearings 	
When the machine is turned on, the spindle does not rotate	<ul style="list-style-type: none"> ● Gearbox failure. 	

Critical state criteria

Critical state criteria	Probable causes	Actions
Cracks on the surfaces of bearing and housing parts	Fatigue deformation of metal	Disconnect the machine from the mains and contact a qualified specialist. Please don't repair the machine by your own.
The power cord or plug is damaged	Overload or breakage	
Excessive wear or damage to the motor or reductor mechanism, or a combination of signs	Fatigue deformation of metal	

Critical state criteria

List of critical failures	Actions
Electric motor sparking	It is necessary to contact a qualified specialist
The appearance of extraneous noise	It is necessary to contact a qualified specialist
If the above malfunctions are detected, it is necessary to disconnect the machine from the mains and contact a qualified specialist	



  **DYLLU Global** www.dyllu.com

KEYWAY TECHNOLOGY (NANTONG) CO.,LTD **MADE IN CHINA** 0125.D01
No.99, Gugang Road, Chongchuan District, Nantong City, China