



说明书材质要求：105g 有光铜版纸	说明书成品尺寸：105*143mm
第一：专色用6级防晒油墨	第二：特别注意： 1. 印刷时看样请参考我司提供的实物样品颜色。不得偏色
	 Pantone 389C  Black (双色印刷)
折叠方式：风琴折 (20P 以下 用风琴折) / 骑马钉 (20P 以上 用骑马钉) 特殊情况：16P/20P：风琴折 + 对折	备注：

## 特别注意：此页内容不印刷

<p>风琴折 + 对折 页面顺序</p> <p><b>16P 页面顺序</b></p> <table border="1" data-bbox="166 733 322 834"> <tr><td>9</td><td>10</td><td>11</td><td>封面</td></tr> <tr><td>12</td><td>13</td><td>14</td><td>封底</td></tr> </table> <table border="1" data-bbox="166 851 322 951"> <tr><td>1</td><td>2</td><td>3</td><td>4</td></tr> <tr><td>5</td><td>6</td><td>7</td><td>8</td></tr> </table>	9	10	11	封面	12	13	14	封底	1	2	3	4	5	6	7	8	<p><b>20P 页面顺序</b></p> <table border="1" data-bbox="650 733 845 834"> <tr><td>11</td><td>12</td><td>13</td><td>14</td><td>封面</td></tr> <tr><td>15</td><td>16</td><td>17</td><td>18</td><td>封底</td></tr> </table> <table border="1" data-bbox="650 851 845 951"> <tr><td>1</td><td>2</td><td>3</td><td>4</td><td>5</td></tr> <tr><td>6</td><td>7</td><td>8</td><td>9</td><td>10</td></tr> </table>	11	12	13	14	封面	15	16	17	18	封底	1	2	3	4	5	6	7	8	9	10
9	10	11	封面																																		
12	13	14	封底																																		
1	2	3	4																																		
5	6	7	8																																		
11	12	13	14	封面																																	
15	16	17	18	封底																																	
1	2	3	4	5																																	
6	7	8	9	10																																	

更改记录	1. 新设计		
	0225.D01	2025.2.10	LYD
	版本号	日期	设计师



# PRODUCT MANUAL

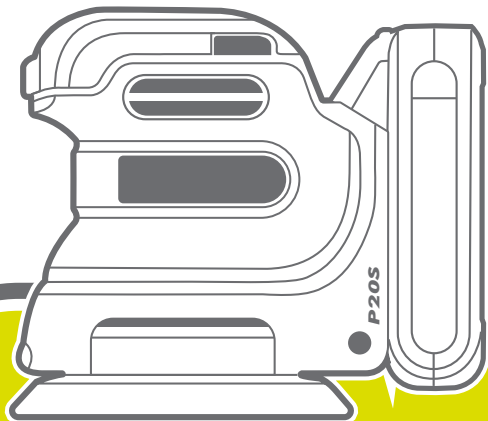

## **CORDLESS RANDOM ORBIT SANDER**

DTRAP5030 UDTRAP5030

DTRAP5030xy UDTRAP5030xy

x(blank,1,2,3,4,5,6,7,8,9,E,S,A,M)

y(blank,-1,-2,-3,-4,-5,-6,-7,-8,-9,E,S,A,M)

*DYLLU, discover your power*

**GENERAL POWER TOOL SAFETY WARNINGS**

**⚠ WARNING!** Read all safety warnings, instructions, illustrations and specifications provided with this power tool. *Failure to follow all instructions listed below may result in electric shock, fire and/or serious injury.*

**Save all warnings and instructions for future reference.**

*The term "power tool" in the warnings refers to your mains-operated (corded) power tool or battery-operated (cordless) power tool.*

**1) Work area safety**

- a) **Keep work area clean and well lit.** *Cluttered or dark areas invite accidents.*
- b) **Do not operate power tools in explosive atmospheres, such as in the presence of flammable liquids, gases or dust.** *Power tools create sparks which may ignite the dust or fumes.*
- c) **Keep children and bystanders away while operating a power tool.** *Distractions can cause you to lose control.*

**2) Electrical safety**

- a) **Power tool plugs must match the outlet. Never modify the plug in any way. Do not use any adapter plugs with earthed (grounded) power tools.** *Unmodified plugs and matching outlets will reduce risk of electric shock.*
- b) **Avoid body contact with earthed or grounded surfaces, such as pipes, radiators, ranges and refrigerators.** *There is an increased risk of electric shock if your body is earthed or grounded.*
- c) **Do not expose power tools to rain or wet conditions.** *Water entering a power tool will increase the risk of electric shock.*
- d) **Do not abuse the cord. Never use the cord for carrying, pulling or unplugging the power tool. Keep cord away from heat, oil, sharp edges or moving parts.** *Damaged or entangled cords increase the risk of electric shock.*
- e) **When operating a power tool outdoors, use an extension cord suitable for outdoor use.** *Use of a cord suitable for outdoor use reduces the risk of electric shock.*
- f) **If operating a power tool in a damp location is unavoidable, use a residual current device (RCD) protected supply.** *Use of an RCD reduces the risk of electric shock.*

### 3) Personal safety

- a) **Stay alert, watch what you are doing and use common sense when operating a power tool. Do not use a power tool while you are tired or under the influence of drugs, alcohol or medication. A moment of inattention while operating power tools may result in serious personal injury.**
- b) **Use personal protective equipment. Always wear eye protection. Protective equipment such as a dust mask, non-skid safety shoes, hard hat or hearing protection used for appropriate conditions will reduce personal injuries.**
- c) **Prevent unintentional starting. Ensure the switch is in the off-position before connecting to power source and/or battery pack, picking up or carrying the tool. Carrying power tools with your finger on the switch or energising power tools that have the switch on invites accidents.**
- d) **Remove any adjusting key or wrench before turning the power tool on. A wrench or a key left attached to a rotating part of the power tool may result in personal injury.**
- e) **Do not overreach. Keep proper footing and balance at all times. This enables better control of the power tool in unexpected situations.**
- f) **Dress properly. Do not wear loose clothing or jewellery. Keep your hair and clothing away from moving parts. Loose clothes, jewellery or long hair can be caught in moving parts.**
- g) **If devices are provided for the connection of dust extraction and collection facilities, ensure these are connected and properly used. Use of dust collection can reduce dust-related hazards.**
- h) **Do not let familiarity gained from frequent use of tools allow you to become complacent and ignore tool safety principles. A careless action can cause severe injury within a fraction of a second.**

### 4) Power tool use and care

- a) **Do not force the power tool. Use the correct power tool for your application. The correct power tool will do the job better and safer at the rate for which it was designed.**
- b) **Do not use the power tool if the switch does not turn it on and off. Any power tool that cannot be controlled with the switch is dangerous and must be repaired.**
- c) **Disconnect the plug from the power source and/or remove the battery**

pack, if detachable, from the power tool before making any adjustments, changing accessories, or storing power tools. *Such preventive safety measures reduce the risk of starting the power tool accidentally.*

- d) **Store idle power tools out of the reach of children and do not allow persons unfamiliar with the power tool or these instructions to operate the power tool.** *Power tools are dangerous in the hands of untrained users.*
- e) **Maintain power tools and accessories. Check for misalignment or binding of moving parts, breakage of parts and any other condition that may affect the power tool's operation. If damaged, have the power tool repaired before use.** *Many accidents are caused by poorly maintained power tools.*
- f) **Keep cutting tools sharp and clean.** *Properly maintained cutting tools with sharp cutting edges are less likely to bind and are easier to control.*
- g) **Use the power tool, accessories and tool bits etc. in accordance with these instructions, taking into account the working conditions and the work to be performed. Use of the power tool for operations different from those intended could result in a hazardous situation.**
- h) **Keep handles and grasping surfaces dry, clean and free from oil and grease.** *Slippery handles and grasping surfaces do not allow for safe handling and control of the tool in unexpected situations.*

#### 5) Battery tool use and care

- a) **Recharge only with the charger specified by the manufacturer.** *A charger that is suitable for one type of battery pack may create a risk of fire when used with another battery pack.*
- b) **Use power tools only with specifically designated battery packs.** *Use of any other battery packs may create a risk of injury and fire.*
- c) **When battery pack is not in use, keep it away from other metal objects, like paper clips, coins, keys, nails, screws or other small metal objects, that can make a connection from one terminal to another.** *Shorting the battery terminals together may cause burns or a fire.*
- d) **Under abusive conditions, liquid may be ejected from the battery; avoid contact. If contact accidentally occurs, flush with water. If liquid contacts eyes, additionally seek medical help.** *Liquid ejected from the battery may cause irritation or burns.*

- e) **Do not use a battery pack or tool that is damaged or modified.** *Damaged or modified batteries may exhibit unpredictable behaviour resulting in fire, explosion or risk of injury.*
- f) **Do not expose a battery pack or tool to fire or excessive temperature.** *Exposure to fire or temperature above 130 °C may cause explosion.*
- g) **Follow all charging instructions and do not charge the battery pack or tool outside the temperature range specified in the instructions.** *Charging improperly or at temperatures outside the specified range may damage the battery and increase the risk of fire.*

## **6) Service**

- a) **Have your power tool serviced by a qualified repair person using only identical replacement parts.** *This will ensure that the safety of the power tool is maintained.*
- b) **Never service damaged battery packs.** *Service of battery packs should only be performed by the manufacturer or authorized service providers*

## BATTERY TOOL SAFETY WARNINGS

Save these instructions.

### **⚠ CAUTION!**

**Only use genuine original batteries.** *Use of non-genuine batteries, or batteries that have been altered, may result in the battery bursting causing fires, personal injury, and damage. It will also void the warranty for the tool and charged and dark areas invite accidents.*

### **⚠ WARNING!**

- a) **Do not dismantle, open or shred secondary cells or batteries.**
- b) **Keep batteries out of the reach of children.** *Battery usage by children should be supervised. Especially keep small batteries out of reach of small children.*
- c) **Seek medical advice immediately if a cell or a battery has been swallowed.**
- d) **Do not expose cells or batteries to heat or fire.** *Avoid storage in direct sunlight.*
- e) **Do not short-circuit a cell or a battery.** *Do not store cells or batteries haphazardly in a box or drawer where they may short-circuit each other or be short-circuited by other metal objects.*
- f) **Do not remove a cell or battery from its original packaging until required for use.**
- g) **Do not subject cells or batteries to mechanical shock.**
- h) **In the event of a cell leaking, do not allow the liquid to come in contact with the skin or eyes.** *If contact has been made, wash the affected area with copious amounts of water and seek medical advice.*
- i) **Do not use any charger other than that specifically provided for use with the equipment.**
- j) **Observe the plus (+) and minus (-) marks on the cell, battery and equipment and ensure correct use.**
- k) **Do not use any cell or battery which is not designed for use with the equipment.**
- l) **Do not mix cells of different manufacture, capacity, size or type within a device.**
- m) **Always purchase the battery recommended by the device manufacturer for the equipment.**
- n) **Keep cells and batteries clean and dry.**
- o) **Wipe the cell or battery terminals with a clean dry cloth if they become**

**dirty.**

- p) **Secondary cells and batteries need to be charged before use.** *Always use the correct charger and refer to the manufacturer's instructions or equipment manual for proper charging instructions.*
- q) **Do not leave a battery on prolonged charge when not in use.**
- r) **After extended periods of storage, it may be necessary to charge and discharge the cells or batteries times to obtain maximum performance.**
- s) **Retain the original product literature for future reference.**
- t) **Use the cell or battery only in the application for which it was intended.**
- u) **When possible, remove the battery from the equipment when not in use.**
- v) **Dispose of properly.**

#### **Tips for maintaining maximum battery life**

- a) **Charge the battery cartridge before completely discharged.** *Always stop tool operation and charge the battery cartridge when you notice less tool power.*
- b) **Never recharge a fully charged battery cartridge.** *Overcharging shortens the battery service life.*
- c) **Charge the battery cartridge with room temperature at 10°C-40°C (50°F-104°F).** *Let a hot battery cartridge cool down before charging it.*
- d) **Charge the battery cartridge if you do not use it for a long period (more than six months).**

#### **Important safety instructions for battery cartridge**

1. **Before using battery cartridge, read all instructions and cautionary markings on battery charger, battery, and) product using battery.**
2. **Do not disassemble battery cartridge.**
3. **If operating time has become excessively shorter, stop operating immediately.** *It may result in a risk of overheating, possible burns and even an explosion.*
4. **If electrolyte gets into your eyes, rinse them out with clear water and seek medical attention right away.** *It may result in loss of your eyesight.*
5. **Do not short the battery cartridge:**
  - *Do not touch the terminals with any conductive material.*
  - *Avoid storing battery cartridge in a container with other metal objects such as nails, coins, etc.*

- *Do not expose battery cartridge to water or rain.*
  - *A battery short can cause a large current flow, overheating, possible burns and even a breakdown.*
6. **Do not store the tool and battery cartridge in locations where the temperature may reach or exceed 50°C (122°F).**
  7. **Do not incinerate the battery cartridge even if it is severely damaged or is completely worn out.** *The battery cartridge can explode in a fire.*
  8. **Be careful not to drop or strike battery.**
  9. **Do not use a damaged battery.**
  10. **Follow your local regulations relating to disposal of battery.**

### **Tool / battery protection system**

The tool is equipped with a tool/battery protection system. This system automatically cuts off power to the motor to extend tool and battery life. The tool will automatically stop during operation if the tool or battery is placed under one of the following conditions:

#### **Overload protection**

When the battery is operated in a manner that causes it to draw an abnormally high current, the tool automatically stops without any indication. In this situation, turn the tool off and stop the application that caused the tool to become overloaded. Then turn the tool on to restart.

#### **Overheat protection**

When the tool/battery is overheated, the tool stops automatically. In this situation, let the tool/battery cool before turning the tool on again.

### **Transportation**

Batteries comply with all applicable shipping regulations as prescribed by industry and legal standards (for more information, check with the manufacturer).

Transporting batteries can possibly cause fire if the battery terminals inadvertently come in contact with conductive materials. When transporting batteries, make sure that the battery terminals are protected and well insulated from materials that could contact them and cause a short circuit.

The information provided in this section of the manual is provided in good faith and believed to be accurate at the time the document was created. However, no warranty, expressed or implied, is given. It is the buyer's responsibility to ensure

that its activities comply with the applicable regulations.

### **Protecting the environment**

Separate collection. This product must not be disposed of with normal household waste.

Should you find one day that your product needs replacement, or if it is of no further use to you, do not dispose of it with household waste. Make this product available for separate collection.

Separate collection of used products and packaging allows materials to be recycled and used again. Re-use of recycled materials helps prevent environmental pollution and reduces the demand for raw materials.











Local regulations may provide for separate collection of electrical products from the household, at municipal waste sites or by the retailer when you purchase a new product.

### **Rechargeable battery pack**

This long-life battery pack must be recharged when it fails to produce sufficient power on jobs which were easily done before. At the end of its technical life, discard it with due care for our environment:

- Run the battery pack down completely, then remove it from the tool.
- Lithium-ion cells are recyclable. Take them to your dealer or a local recycling station. The collected battery packs will be recycled or disposed of properly.

## THE SYMBOLS IN INSTRUCTION MANUAL

	<p>Double insulated for additional protection</p>
	<p>Read the instruction manual before using.</p>
	<p>CE conformity.</p>
	<p>Safety alert. Please only use the accessories supported by the manufacturer.</p>
	<p>Wear safety glasses, hearing protection and dust mask.</p>
	<p>Waste electrical products should not be disposed of with household waste. Please recycle where facilities exist. Check with your Local Authority or retailer for recycling advice.</p>
	<p>Charging the battery only below 40°C</p>
	<p>Always recycle batteries.</p>
	<p>Do not destroy battery by fire.</p>
	<p>Do not expose battery to water</p>

## ADDITIONAL SAFETY WARNINGS

### Sander safety warnings

- a) **Hold the power tool by insulated gripping surfaces, because the sanding surface may contact its own cord.** *Cutting a "live" wire may make exposed metal parts of the power tool "live" and could give the operator an electric shock.*
- b) **Always use safety glasses or goggles.** *Ordinary eyes or sunglasses are NOT safety glasses.*
- c) **Hold the tool firmly.**
- d) **Do not leave the tool running.** *Operate the tool only when hand-held.*
- e) **This tool has not been waterproofed, so do not use water on the workpiece surface.**
- f) **Ventilate your work area adequately when you perform sanding operations.**
- g) **Some material contains chemicals which may be toxic.** *Take caution to prevent dust inhalation and skin contact. Follow material supplier safety data.*
- h) **The use of this tool to sand some products, paints, and wood could expose user to dust containing hazardous substances.** *Use appropriate respiratory protection.*
- i) **Be sure that there are no cracks or breakage on the pad before use.** *Cracks or breakage may cause a personal injury.*
- j) **Watch your footing and maintain your balance with the tool.** *Make sure there is no one below when working in high locations.*

## INTENDED USE

The power tool is intended for dry sanding of wood, plastic, metal, filler and varnished surfaces.

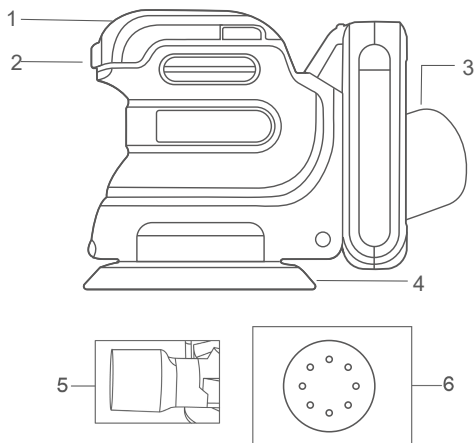
**SPECIFICATIONS****Components**

- |                   |                         |
|-------------------|-------------------------|
| 1. Hand grip area | 4. Rotary sanding plate |
| 2. ON/OFF switch  | 5. Vacuum adaptor       |
| 3. Dust bag       | 6. Sand paper           |

## Technical specifications

Model No.	DTRAP5030 DTRAP5030xy	UDTRAP5030 UDTRAP5030xy
<b>Bottom size</b>	125mm(5")	
<b>No-load speed</b>	8000-13000/min	
<b>Rated voltage</b>	20V	

**Model No. Note:** x (blank, 1,2,3,4,5,6,7,8,9,E,S,A,M); y (blank, -1,-2,-3,-4,-5,-6,-7,-8,-9,E,S,A,M)

- Due to our continuing program of research and development, the specifications herein are subject to change without notice.s

**⚠ WARNING!**

Only use original battery pack and battery charger as below for this power tool:

Product	Battery pack		
Model No.	Type	Rated voltage	Rated capacity
DTLBP515 DTLBP515xy	Lithium-Ion	18.5V d.c., 20V Max	1.5Ah
DTLBP520 DTLBP520xy			2.0Ah
DTLBP530 DTLBP530xy			3.0Ah
DTLBP540 DTLBP540xy			4.0Ah
DTLBP550 DTLBP550xy			5.0Ah

**Model No. NOTE:** x (blank, 1,2,3,4,5,6,7,8,9,E,S,A,M); y (blank, -1,-2,-3,-4,-5,-6,-7,-8,-9,E,S,A,M)

Product	Battery pack charger			
Model No.	Input power	Input voltage	Output rated voltage	Output rated current
DTFPCP518 DTFPCP518xy	45W	220-240V ~50/60Hz	20V d.c.	1.8A
UDTFPCP518 UDTFPCP518xy		110-120V ~50/60Hz		
DTFPCP540 DTFPCP540xy	105W	220-240V ~50/60Hz	20V d.c.	4A
UDTFPCP540 UDTFPCP540xy		110-120V ~50/60Hz		

**Model No. NOTE:** x (blank, 1,2,3,4,5,6,7,8,9,E,S,A,M); y (blank, -1,-2,-3,-4,-5,-6,-7,-8,-9,E,S,A,M)

## OPERATION PICTURE

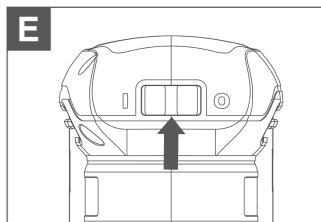
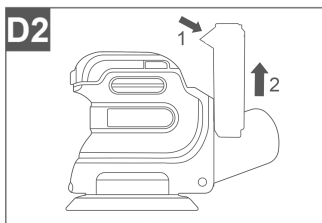
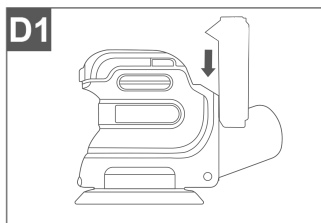
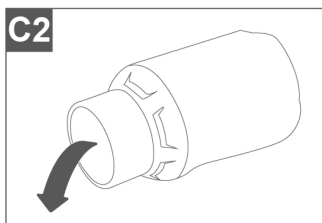
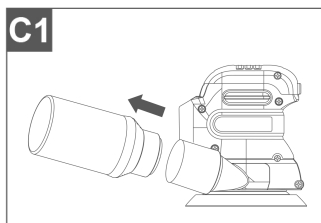
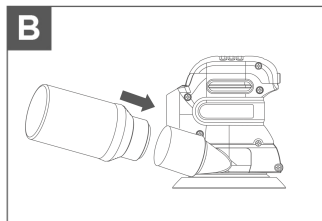
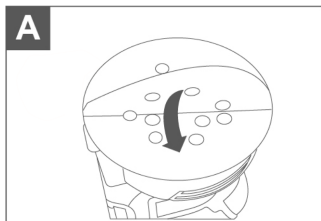

## FUNCTION DESCRIPTION

### Caution

**Before using the tool, read the instruction book carefully.**

### Intended use

The machine is intended for dry sanding of wood, plastic, metal and filler material as well as painted surfaces.

Machines with electronic control are also suitable for polishing.

### Assembly

#### 1. Assemble the sanding paper (see Dia A)

- 1) Remove any dust or other objects from the sanding plate and sandpaper.
- 2) The sandpaper has dust extraction holes you must align these with the holes in the sanding plate, otherwise the dust extraction will not function.

#### 2. Assemble the dust bag

##### —Attaching the dust bag (see Dia B)

Always operate your sander with the dust bag fitted.

To attach, slide the dust bag onto tool.

### Caution

**To prevent the possibility of sanding dust or foreign body being thrown in to your face or eyes, never attempt to use your sander without the dust bag properly installed**

##### —Empty the dust bag (see Dia C)

For more efficient operation, empty the dust bag every 5-10mins.

To empty the dust bag, pull the dust bag out and shake out dust.

#### 3. Install and remove the battery pack (see Dia D)

Slide the fully charged Battery Pack onto the tool with sufficient force until it clicks into position.

Depress the Battery Pack Release Button firmly first and then slide the Battery Pack out from your tool.

## OPERATION

### 1.ON/OFF Switch (see Dia E)

To start your sander, depress the protective cover over the switch indicated by the mark "I".

To stop your sander, depress the protective cover indicated by the mark "O".

### 2. Sanding surfaces

Place the machine with the complete Sand paper on the surface to be worked. Ensure uniform sanding pressure. Less sanding pressure increases the sanding capacity and protects the machine and the sanding tool. The removal capacity and the sanding pattern are determined mainly by the selection of the Sand paper (grain size), the speed of the sanding plate and the application pressure.

#### Rough sanding

Attach a Sand paper with coarse grain. Apply only light sanding pressure to achieve increased material removal.

#### Fine sanding

Attach a Sand paper with fine grain. With moderate pressure, move the machine in a circular pattern or alternately in lengthwise and crosswise directions over the workpiece. Do not tilt the machine to avoid sanding through the work piece(e.g. when sanding veneer). After finishing the work, switch off the machine and lift it from the workpiece.

### 3.Orbital sanding

Guide your sander parallel to the working surface and move it in circles or in a cross pattern. Do not tilt the tool in order to avoid deep unwanted sanding marks. The amount of material removed is determined by the speed of the sanding disc and the grit size used. The speed of the sanding disc diminishes relative to the pressure applied to the tool. For faster removal, do not increase pressure on the tool, but use a coarser grit size.

### 4. Selecting the right grade of sandpaper

Different grades of sanding paper can be purchased from good DIY shops. Available grades are Coarse, Medium and Fine.

Use coarse grits to sand down rough finishes, medium grit to smooth the work and fine grit to finish off.

The higher the grade number, the finer the grit. For rough work start with a low grade of grit. (e.g. 60 grit) and change to a higher, finer grade (e.g. 120 grit) for finishing. If you use a fine grade for rough surfaces it will soon clog and need changing. It is best to make a trial run on a scrap piece of material to determine the optimum grades of sandpaper for a particular job.

## MAINTENANCE&MALFUNCTIONS

### Possible malfunctions and methods of their eliminations

Malfunction	Probable causes	Actions
When the machine is turned on, the electric motor does not work.	<ul style="list-style-type: none"> <li>● Switch failure</li> <li>● The power cord or wiring is broken, power cord plug malfunction;</li> <li>● No brush contact with the collector;</li> <li>● Wear/damage of brushes</li> </ul>	Disconnect the machine from the mains and contact a qualified specialist.
Formation of a circular fire on the collector	<ul style="list-style-type: none"> <li>● Brush wear/damage of the brush holder;</li> <li>● Malfunction in the armature coil</li> </ul>	Disconnect the machine from the mains and contact a qualified specialist. Please don't repair the machine by your own.
When working, smoke or the smell of burning insulation appears from the ventilation openings.	<ul style="list-style-type: none"> <li>● Malfunction in the electric motor coil;</li> <li>● Malfunction of the electrical part of the tool.</li> </ul>	
Increased noise in the gearbox	<ul style="list-style-type: none"> <li>● Wear/breakage of gears or bearings</li> </ul>	
When the machine is turned on, the spindle does not rotate	<ul style="list-style-type: none"> <li>● Gearbox failure.</li> </ul>	

### Critical state criteria

Critical state criteria	Probable causes	Actions
Cracks on the surfaces of bearing and housing parts	Fatigue deformation of metal	Disconnect the machine from the mains and contact a qualified specialist. Please don't repair the machine by your own.
The power cord or plug is damaged	Overload or breakage	
Excessive wear or damage to the motor or reductor mechanism, or a combination of signs	Fatigue deformation of metal	

### Critical state criteria

List of critical failures	Actions
Electric motor sparking	It is necessary to contact a qualified specialist
The appearance of extraneous noise	It is necessary to contact a qualified specialist
If the above malfunctions are detected, it is necessary to disconnect the machine from the mains and contact a qualified specialist	



  **DYLLU Global** [www.dyllu.com](http://www.dyllu.com)

**KEYWAY TECHNOLOGY (NANTONG) CO., LTD** MADE IN CHINA 0225.D01  
No. 99, Gugang Road, Chongchuan District, Nantong City, China