

Oil Service Units
ECOLINE · UM 045 · UMP 045 · UMPC 045

Oil service – simple, quick and compact · with integrated particle monitor



UM 045



UMPC 045



OPCOM I(integrated in UMPC)

- › Easy filling, cleaning and pumping over
- › Unbeatable ergonomics, optimal handling
- › High filtration performance
- › May be combined with portable oil diagnostic system optionally
- › Optionally with integrated particle monitor
- › Optionally with integrated humidity sensor

ECOLINE
Easy, compact and ergonomic

With ECOLINE hydraulic or lubrication systems can simply be filled, cleaned or fluid can be pumped over without using the filter function. The ergonomic design allows simple handling also on closest work space.

Protection of components through ultra-fine filtration

The EXAPOR®MAX 2 ultra-fine element is the heart of the ARGO-HYTOS oil service unit ECOLINE. High separation efficiency guarantees excellent cleanliness levels and thereby highest protection of components. The high dirt holding capacity of the EXAPOR®MAX 2 ultra-fine elements allows economic operation of the ECOLINE.

ECOLINE base model – UM 045

The UM 045 is delivered equipped with hoses, and is ready to connect. For easy transport, electrical cables, as well as suction and return hose, are mounted with support fixtures on the carrier device. The tool can be stowed in the basket of the carrier device.

ECOLINE with integrated particle monitor – UMPC 045

The integrated particle monitor in the UMPC 045 permanently monitors the oil cleanliness during the filtering process. The humidity sensor (LubCos H₂O) permanently monitors the oil humidity during the filtering process.

Cleanliness class monitoring can be selected for “cleaning” or “filling” with a change-over cock. The ordinal numbers of the particle sizes are shown on the display in accordance with ISO 4406:1999. Also the humidity in %rh is shown on the display.

Via a W-LAN SD card data can be transmitted to a computer or Smartphone during measurement. If data transmission is not possible, the data are stored on the SD card and can be retrieved at a later point in time.

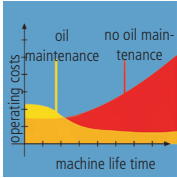

Economical

Efficiency through ARGO-HYTOS Fluid Management systems. Fast return on investment by extended service intervals and increased machine availability.



User-friendly filter element change

The filter element can be removed from the housing together with the cover. The dirt retention valve ensures that solid particle sediment is completely removed with the filter element. During operation, the fluid passes through the filter element from the inside to the outside, which eliminates the need for flushing the filter housing.



Switching functions

The rotary valve is used to switch between the basic modes of operation: "filtering" and "pumping over without filtering".



Keeping hoses in place

The retainers attached to the sides of the frame secure the hoses in any transport position.



Compact design

Among the numerous advanced features, listed in the specification of the ECOLINE, compact design was a basic requirement to be met by our team of design engineers. Transporting the ECOLINE in horizontal position, e.g. in the cargo area of a service vehicle, is facilitated by the wheels and the curved design of the frame.



Unbeatable ergonomics

Superior technology and excellent design are of no use if the service equipment requires great physical effort from the operator. Therefore, ergonomics were of primary importance when the ECOLINE design was conceived.

Owing to its optimized weight distribution, the ECOLINE can be tilted from the standing position with minimum effort. In the tilted position, the ECOLINE can be moved walking upright, removing strain from the back.

Cleaning speed

The cleaning speed depends on the efficiency of the filter elements ($\beta_{x(c)}$), the nominal volume flow ($Q_{nominal}$) and the oil volume (V_{actual}).

In graph D1-D2 the cleaning speeds are shown in relation to the filter fineness (cleanliness information according to ISO 4406:1999). The values are recorded by laboratory methods and they may be influenced by environmental conditions (such as continuous additional introduction of dirt on running systems, high water content, etc.).

All characteristic curves (see graphs D1-D2) relate to a **reference oil volume of 180 l** and a **nominal volume flow of 15 l/min**.

The following formula should be used to convert to the actual oil volume:

$$t_{actual} = \frac{V_{actual} \cdot \Delta t}{12 \cdot Q_{nominal}}$$

- t_{actual} = actual cleaning speed
- Δt = cleaning speed for oil volume of 180 l
- V_{actual} = volume of oil to be cleaned
- $Q_{nominal}$ = nominal volume flow, see selection chart

For monitoring purposes we recommend the ARGO-HYTOS OPCOM which is built in the version FAPC 016 or the oil particle counter OPCOUNT.

Determining the cleaning speed

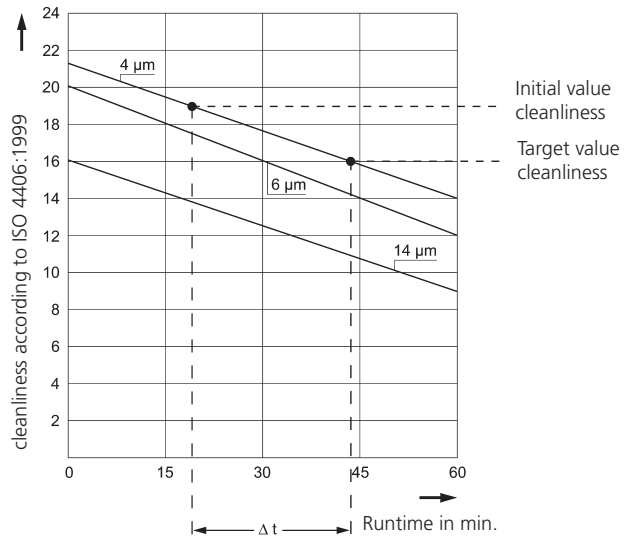

- › Determine the initial cleanliness class and enter it on the graph, e. g. 19/17/14 according to ISO 4406:1999
- › Enter the target cleanliness class on the graph, e.g. 16/14/11 according to ISO 4406:1999
- › Determine Δt , in this case $\Delta t = 25$ min
- › Insert the value in the formula, where $V_{actual} = 350$ l and $Q_{nominal} = 16$ l/min

$$t_{actual} = \frac{V_{actual} \cdot \Delta t}{12 \cdot Q_{nominal}} = \frac{350 \cdot 25}{12 \cdot 16} \approx 46 \text{ min}$$

Curves for cleaning speed as a function of the filter fineness

D1 3EN2 and 5EN2 EXAPOR®MAX 2 filter element
Reference oil volume with $Q_{off-line \text{ filter}} = 15$ l/min.

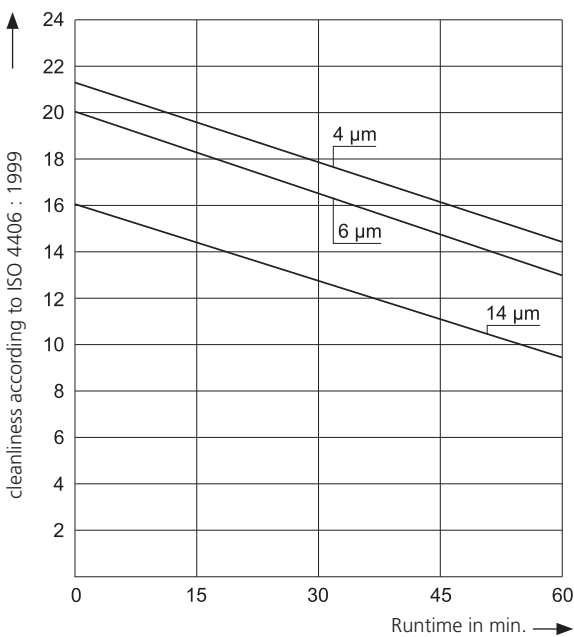

D2 10EX2 EXAPOR®MAX 2 filter element
Reference oil volume with $Q_{off-line \text{ filter}} = 15$ l/min.

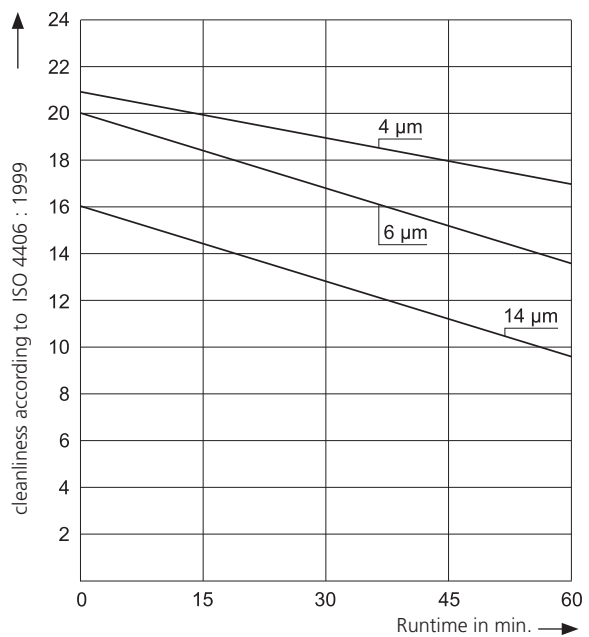

Filter fineness curves in selection chart

Dx Filtration ratio β as a function of particle size x obtained by the Multi-Pass-Test according to ISO 16889

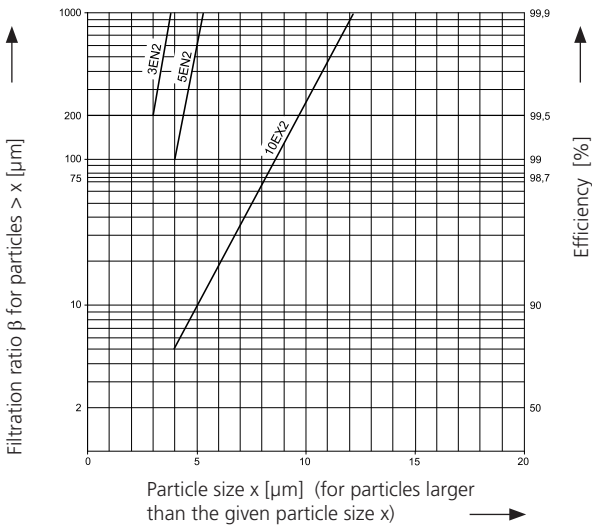

The abbreviations represent the following β -values resp. finenesses:

For EXAPOR[®]MAX2-elements:

- 3EN2 = $\bar{\beta}_{3(c)}$ = 200 EXAPOR[®]MAX2
- 5EN2 = $\bar{\beta}_{5(c)}$ = 200 EXAPOR[®]MAX2
- 10EX2 = $\bar{\beta}_{10(c)}$ = 200 EXAPOR[®]MAX2

Characteristics

Hydraulic connection

Hoses:
Suction hose NG 32, length 2,7 m, with suction strainer 280 μ m,
pressure hose NG 25, length 2,7 m

Electrical connection / Electric motor

Electric motor, air cooled fan type
Cable: length 6 m
Electro motor types: 1 ~ 230 V / 50 Hz
3 ~ 400 V / 50 Hz
(3 ~ 460 V / 60 Hz)
Type of protection: IP 54
(See selection chart)

Tank capacity

approx. 13 l

Pump design

Internal gear pump

Operating and transportation position

Operating position: upright
Transportation position: upright or horizontal

Hydraulic fluids

Mineral oil and biodegradable fluids
(HEES and HETG, see info service sheet 00.20).
Other fluids on request.

Temperature range of fluids

0 °C ... +65 °C (also see fluid viscosity range)

Ambient temperature range

0 °C ... +50 °C

Options

Water-absorbing filter elements EXAPOR[®]AQUA
These can be used for short-term water absorption in
all standard units. (please inquire).

Viscosity range

Type	Continuous operation min.	Continuous operation max..	Short-term operation max.
UM 045	15 mm ² /s	600 mm ² /s	800 mm ² /s
UMPC 045	15 mm ² /s	250 mm ² /s* 600 mm ² /s*	800 mm ² /s

*Precise determination of the cleanliness class is possible within a viscosity range of 15 mm²/s to 250 mm²/s

Dimensions

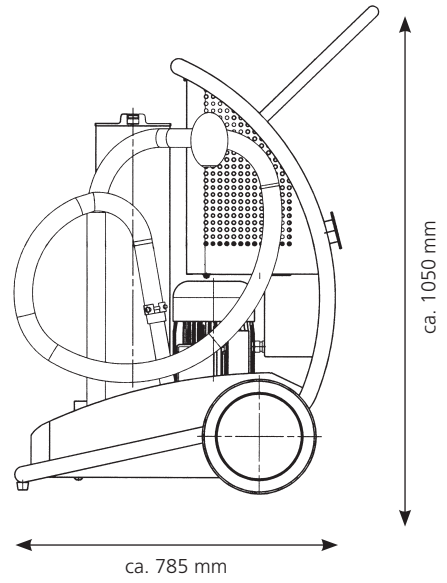
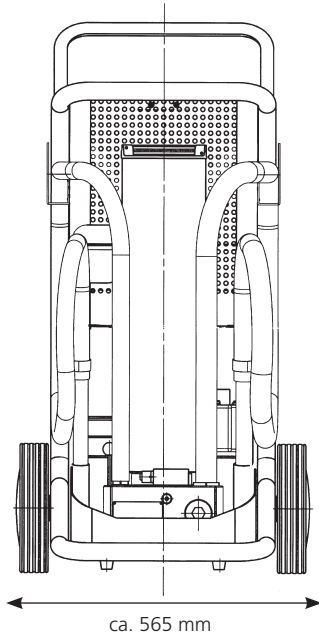

Hydraulic symbol - UM 045

1

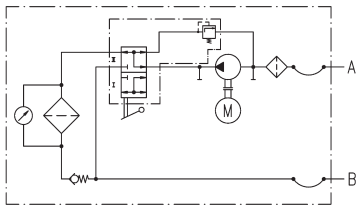

Hydraulic symbol - UMPC 045

2

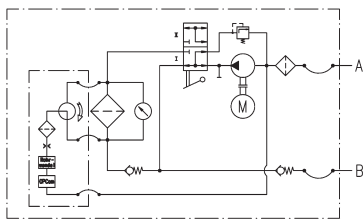

Selection Chart

Order No.	Nominal flow rate	Filter fineness see diagram Dx	Dirt capacity Mi at Q _{nom}	E-Motor operating voltage	E-Motor max. operating frequency	E-Motor power	Length suction hose (lance incl.)	Length pressure hose (lance incl.)	Viscosity	Suction height max.	Hydraulic symbol	Replacement element order no.	Clogging indicator	Weight
ECOLINE basic model - UM 045														
UM 045-1553	45 l/min***	3EN2	1.950 g	1~230 V	50/60 Hz	1,1 kW***	2,7 m	2,7 m	15 ... 600 mm ² /s	2,0 m	1	V7.1560-103	optical	76,5 kg
UM 045-4553	45 l/min***	3EN2	1.950 g	3~400V 50 Hz 3~460V 60 Hz	50/60 Hz	1,1 kW***	2,7 m	2,7 m	15 ... 600 mm ² /s	2,0 m	1	V7.1560-103	optical	76,5 kg
UM 045-1153	45 l/min***	5EN2	1.980 g	1~230 V	50/60 Hz	1,1 kW***	2,7 m	2,7 m	15 ... 600 mm ² /s	2,0 m	1	V7.1560-03	optical	76,5 kg
UM 045-4153	45 l/min***	5EN2	1.980 g	3~400V 50 Hz 3~460V 60 Hz	50/60 Hz	1,1 kW***	2,7 m	2,7 m	15 ... 600 mm ² /s	2,0 m	1	V7.1560-03	optical	76,5 kg

ECOLINE with integrated particle monitor OPCom – UMPC 045														
UMPC 045-15735	45 l/min***	3EN2	1.950 g	1~230 V	50/60 Hz	1,1 kW***	2,7 m	2,7 m	15 ... 600 mm ² /s*	2,0 m	2	V7.1560-103	electrical	97 kg
UMPC 045-45735	45 l/min***	3EN2	1.950 g	3~400V 50 Hz 3~460V 60 Hz	50/60 Hz	1,1 kW***	2,7 m	2,7 m	15 ... 600 mm ² /s*	2,0 m	2	V7.1560-103	electrical	97 kg

Please request our data sheet no. 100.10 for more detailed information on the OPCom particle monitor.

- * The exact determination of the cleanliness class is possible in a viscosity range of 15 mm²/s to 250 mm²/s.
- ** Indications at 50 Hz. At 60 Hz the value increases by 20 %.

Other versions on request

Filter elements:

see selection chart.

Water-absorbing filter elements EXAPOR®AQUA on request.

Accessories:

Hose extensions on request.

For the appropriate clogging indicators see datasheet 60.20.