

# Product data sheet

Specifications



## Regulated Power Supply, modicon power supply, 100...240V AC, 24V, 6.2A, single phase, Panel Mount

ABLP1A24062

**Product availability: Stock - Normally stocked in distribution facility**

### Main

Range of Product	Modicon Power Supply
Product or Component Type	Power supply
Power supply type	Regulated switch mode
Variant option	Panel mount
Enclosure Material	Aluminum
Nominal input voltage	100...120 V AC single phase 200...240 V AC single phase
Rated power in W	150 W
Output voltage	24 V DC
Power supply output current	6.25 A

### Complementary

Efficiency at full load	90...132 V AC 170...264 V AC
Nominal network frequency	50...60 Hz
Network system compatibility	TN TT IT
Maximum leakage current	1 mA 240 V AC
Input protection type	Integrated fuse (not interchangeable) 4 A
Inrush current	35 A 115 V 70 A 230 V
Power factor	0.55 at 115 V AC 0.45 at 230 V AC
Efficiency	88.8 % 230 V AC
Output voltage adjustment	21.6...26.4 V
Power dissipation in W	29 W
Current consumption	< 3.2 A 115 V AC < 1.9 A 230 V AC
Turn-on time	< 500 ms
Holding time	> 20 ms 115 V AC > 40 ms 230 V AC
Startup with capacitive loads	7000 µF
Residual ripple	< 170 mV
Meantime between failure [MTBF]	700000 h at 77 °F (25 °C), full load conforming to SR 332

Price is "List Price" and may be subject to a trade discount – check with your local distributor or retailer for actual price.

<b>Output protection type</b>	Against overload and short-circuits, protection technology: automatic reset Against over temperature, protection technology: manual reset Against overvoltage, protection technology: manual reset
<b>Connections - terminals</b>	Screw connection 0.75...2.5 mm <sup>2</sup> , AWG 18...AWG 14) without wire end ferrule Screw connection 0.75...1.5 mm <sup>2</sup> , AWG 18...AWG 16) with wire end ferrule
<b>Line and load regulation</b>	< 0.5 % network 0 to 100 % load at 77 °F (25 °C) < 1 % network full voltage range in line at 77 °F (25 °C)
<b>Status LED</b>	1 LED (Green) output voltage
<b>Depth</b>	6.3 in (159 mm)
<b>Height</b>	1.2 in (30 mm)
<b>Width</b>	3.8 in (97 mm)
<b>Product Weight</b>	0.79 lb(US) (0.36 kg)
<b>Output coupling</b>	Parallel Serial
<b>Mounting support</b>	Top hat type TH35-15 rail IEC 60715 Top hat type TH35-7.5 rail IEC 60715 Double-profile DIN rail panel mounting
<b>Supply</b>	SELV IEC 60950-1 SELV IEC 60204-1 SELV IEC 60364-4-41
<b>Dielectric strength</b>	3750 V AC with input to output
<b>Service life</b>	10 year(s)
<b>Overvoltage category</b>	II

## Environment

<b>Standards</b>	IEC 62368-1 EN/IEC 61010-1 EN 61010-2-201 EN/IEC 61204-3 IEC 61000-6-1 IEC 61000-6-2 IEC 61000-6-3 IEC 61000-6-4 IEC 61000-3-2 EN 61000-3-3 UL 62368-1 UL 61010-1 UL 61010-2-201 CSA C22.2 No 62368-1 CSA C22.2 No 61010-1 CSA C22.2 No 61010-2-201 IEC 60335-1
<b>Product certifications</b>	CE CULus EAC RCM CB Scheme KC
<b>Operating altitude</b>	5000 m
<b>Shock resistance</b>	150 m/s <sup>2</sup> 11 ms
<b>IP degree of protection</b>	IP10
<b>Ambient air temperature for operation</b>	-22...-13 °F (-30...-25 °C) with current derating of 4 % per °C mounting position B, G < 6561.68 ft (2000 m) -13...122 °F (-25...50 °C) without derating mounting position B, G < 6561.68 ft (2000 m) 122...158 °F (50...70 °C) with current derating of 2 % per °C mounting position B, G < 6561.68 ft (2000 m)
<b>Electrical shock protection class</b>	Class I

<b>Pollution degree</b>	2
<b>Vibration resistance</b>	3 mm (f= 2...9 Hz) conforming to IEC 60068-2-6 10 m/s² (f= 9...200 Hz) conforming to IEC 60068-2-6
<b>Electromagnetic immunity</b>	Immunity to electrostatic discharge - test level: 8 kV (contact discharge) conforming to IEC 61000-4-2 Immunity to electrostatic discharge - test level: 15 kV (air discharge) conforming to IEC 61000-4-2 Immunity to conducted RF disturbances - test level: 15 V/m (80 MHz...2 GHz) conforming to IEC 61000-4-3 Immunity to conducted RF disturbances - test level: 5 V/m (2...2.7 GHz) conforming to IEC 61000-4-3 Immunity to conducted RF disturbances - test level: 5 V/m (2.7...6 GHz) conforming to IEC 61000-4-3 Immunity to fast transients - test level: 4 kV (on input-output) conforming to IEC 61000-4-4 Surge immunity test - test level: 4 kV (between power supply and earth) conforming to IEC 61000-4-5 Surge immunity test - test level: 3 kV (between phases) conforming to IEC 61000-4-5 Immunity to conducted RF disturbances - test level: 15 V (0.15...80 MHz) conforming to IEC 61000-4-6 Immunity to magnetic fields - test level: 30 A/m (50...60 Hz) conforming to IEC 61000-4-8 Immunity to voltage dips conforming to IEC 61000-4-11 Disturbing field emission conforming to EN 55016-2-3 Limits for harmonic current emissions conforming to IEC 61000-3-2 conforming to EN 55016-1-2 conforming to EN 55016-2-1
<b>Electromagnetic emission</b>	Conducted emissions IEC 61000-6-3 Radiated emissions IEC 61000-6-4

## Ordering and shipping details

<b>Category</b>	US1CP1222524
<b>Discount Schedule</b>	CP12
<b>GTIN</b>	3606481500298
<b>Returnability</b>	Yes
<b>Country of origin</b>	CN

## Packing Units

<b>Unit Type of Package 1</b>	PCE
<b>Nbr. of units in pkg.</b>	1
<b>Package 1 Height</b>	1.575 in (4.000 cm)
<b>Package 1 Width</b>	5.748 in (14.600 cm)
<b>Package 1 Length</b>	8.465 in (21.500 cm)
<b>Package weight(Lbs)</b>	17.284 oz (490.000 g)
<b>Unit Type of Package 2</b>	S03
<b>Number of Units in Package 2</b>	17
<b>Package 2 Height</b>	11.8 in (30 cm)
<b>Package 2 Width</b>	11.8 in (30 cm)
<b>Package 2 Length</b>	15.7 in (40 cm)
<b>Package 2 Weight</b>	19.599 lb(US) (8.890 kg)

## Contractual warranty

<b>Warranty (in months)</b>	18
-----------------------------	----



## Environmental Data

Schneider Electric aims to achieve Net Zero status by 2050 through supply chain partnerships, lower impact materials, and circularity via our ongoing “Use Better, Use Longer, Use Again” campaign to extend product lifetimes and recyclability.

[Environmental Data explained >](#)

[How we assess product sustainability >](#)



### Environmental footprint

Total lifecycle Carbon footprint	1 252 kg CO2 eq.
Carbon footprint of the manufacturing phase [A1 to A3]	7 kg CO2 eq.
Carbon footprint of the distribution phase [A4]	0.1 kg CO2 eq.
Carbon footprint of the installation phase [A5]	0 kg CO2 eq.
Carbon footprint of the use phase [B2, B3, B4, B6]	1 245 kg CO2 eq.
Carbon footprint of the end-of-life phase [C1 to C4]	0.3 kg CO2 eq.
Environmental Disclosure	<a href="#">Product Environmental Profile</a>

## Use Better



### Materials and Substances

Packaging made with recycled cardboard	No
Packaging without single use plastic	Yes
SCIP Number	E8b5e85f-3dd8-4246-afe7-a3c3cb549e5c
EU RoHS Directive	<a href="#">Compliant By Exemption</a>
REACH Regulation	<a href="#">Reference contains Substances of Very High Concern above the threshold</a>
California proposition 65	<b>WARNING:</b> This product can expose you to chemicals including: Lead and lead compounds, which is known to the State of California to cause cancer and birth defects or other reproductive harm. For more information go to <a href="http://www.P65Warnings.ca.gov">www.P65Warnings.ca.gov</a>

## Use Longer



### Lifetime extension

Repair	No
--------	----

## Use Again



### Repack and remanufacture

Circularity Profile	<a href="#">End of Life Information</a>
Take-back	Nej
WEEE Label	 The product must be disposed on European Union markets following specific waste collection and never end up in rubbish bins.

## Dimensions Drawings

### Electrical Safety

---

- If the unit is use in a manner not specified by the manufacturer, the protection provided by the equipment may be impaired.
- For means of disconnection a switch or circuit breaker, located near the product, must be included in the installation. A marking as disconnecting device for the product is required.
- The device has an internal fuse. The unit is tested and approved with branch circuit protective device up to 20A. This circuit breaker can be used as disconnecting device.
- The power supply is only suitable for audio, video, information, communication, industrial and control equipment.

Dimensions

---

Front and Side Views

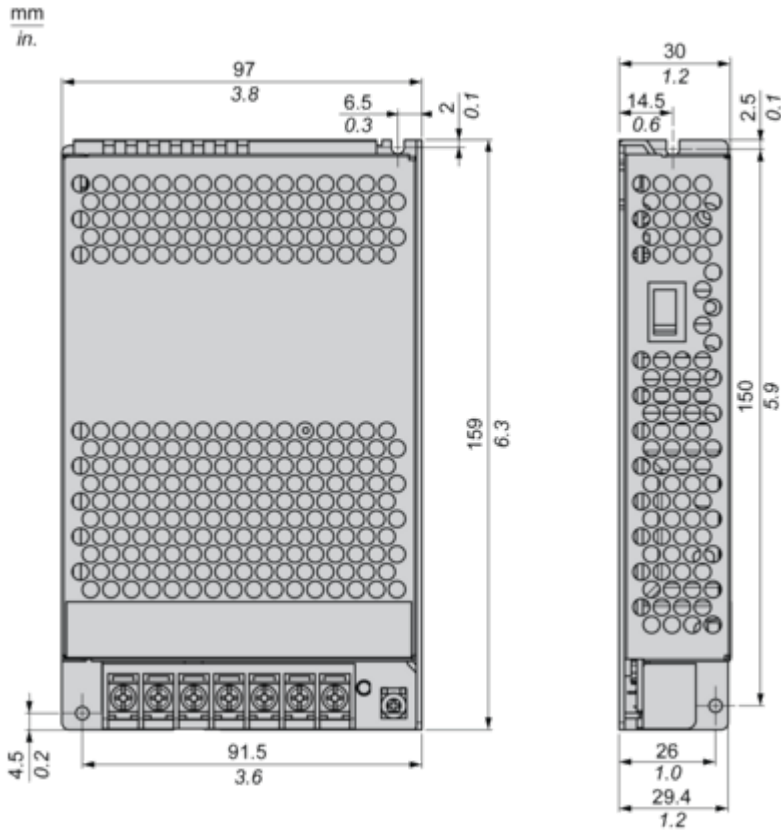

Connections and Schema

Connections and Schema

Correct Parallel Connection

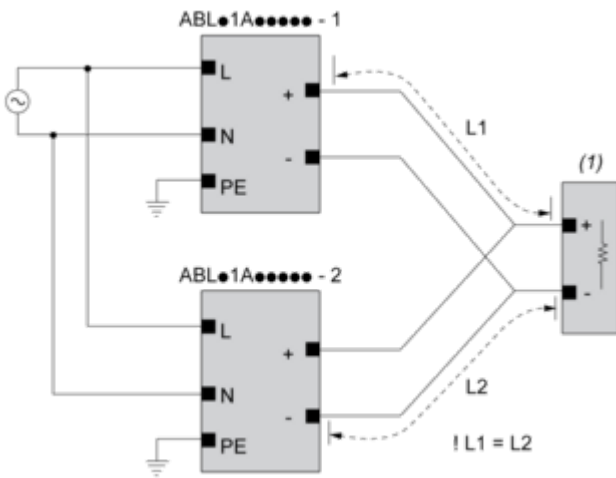

(1) : Load

Incorrect Parallel Connection

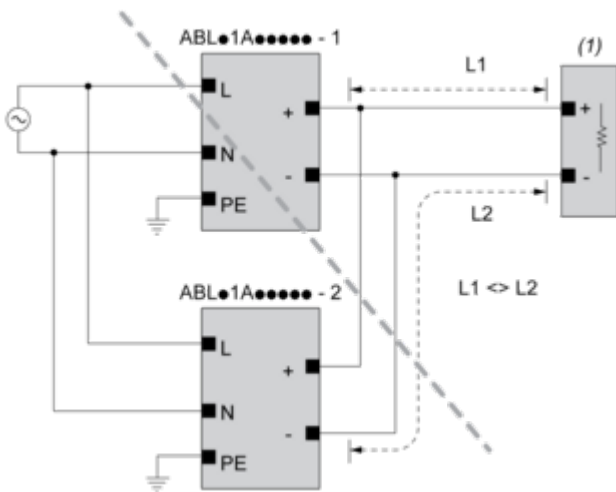

(1) : Load

$ABLx1Axxxx-1 = ABLx1Axxxx-2$

max 2 x ABLx1Axxxx

$L1 = L2$

$\Delta V$  max 25 mV

$I_{Load} < 90\% \cdot 2 \cdot I_{nom}$

Output Voltage Balancing

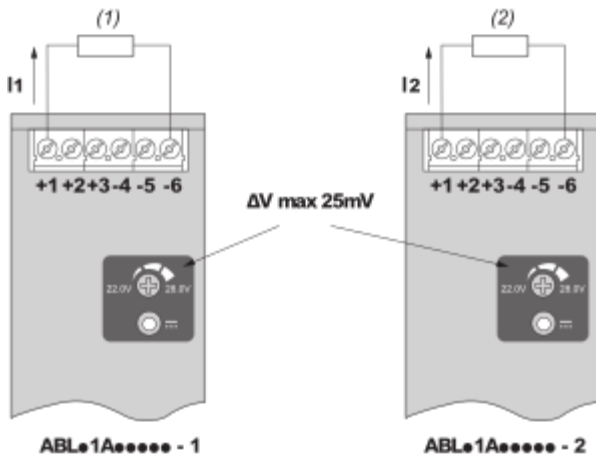

(1) :  $R_{Load1}$

(2) :  $R_{Load2}$

$R_{Load1} = R_{Load2}$

$I_1 = I_2 = \sim I_{nom}$

**Series Connection**

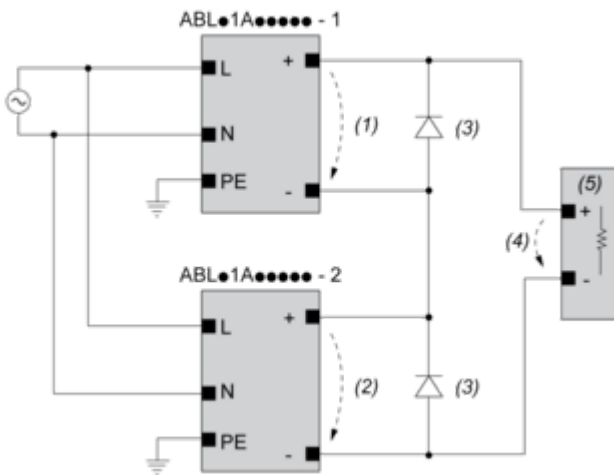

(1) :  $V_{out1}$

(2) :  $V_{out2}$

(3) : 2 x Diode,  $V_{RRM} > 2 \times V_{out1/2}$ ,  $I_F > 2 \times I_{nom1/2}$

(4) :  $V_{Load} = 2 \times V_{out}$

(5) : Load

Connections and Schema

---

	(1)		
	<40°C	<50°C	<70°C
ABLP1A12085	60°C	70°C	90°C
ABLP1A24045	60°C	70°C	90°C
ABLP1A24062	60°C	70°C	90°C
ABLP1A24100	60°C	70°C	90°C

(1) : Ambient

Mounting and Clearance

Mounting

---

Mounting Position B

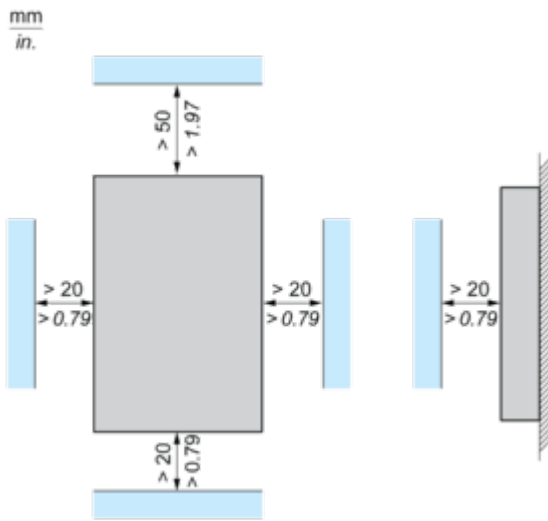

Mounting Position F

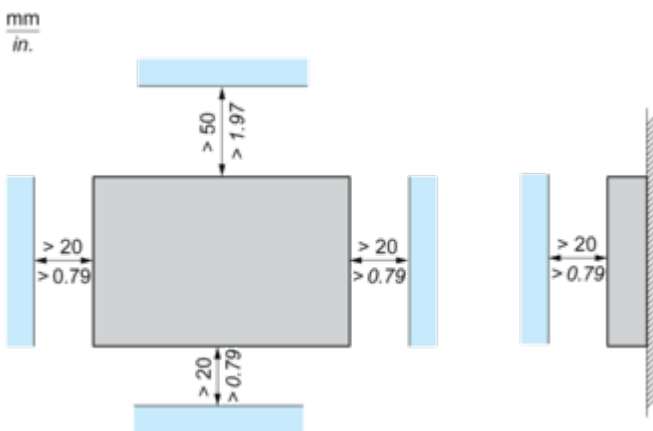

Mounting Position G

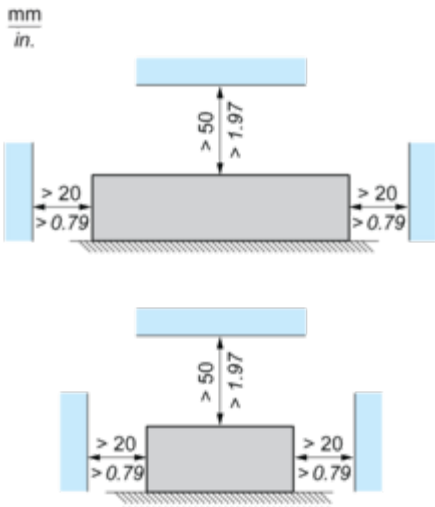

Mounting Position H

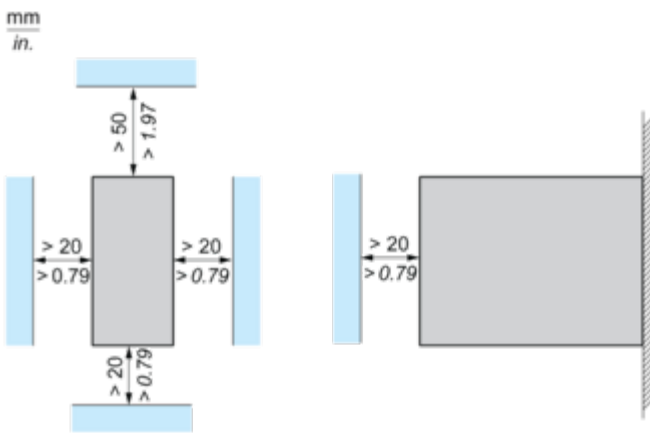

Performance Curves

Performance Curves

---

Mounting Position B and G

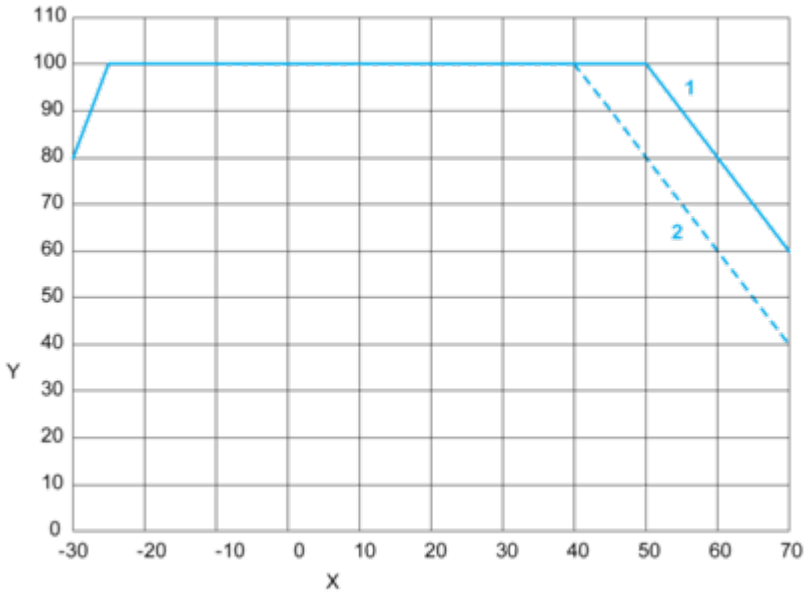

Mounting Position F

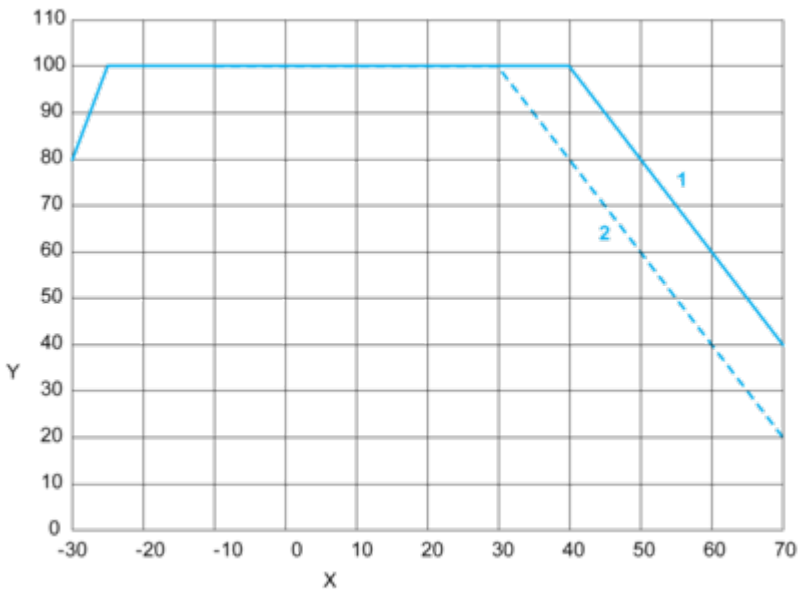

Mounting Position H

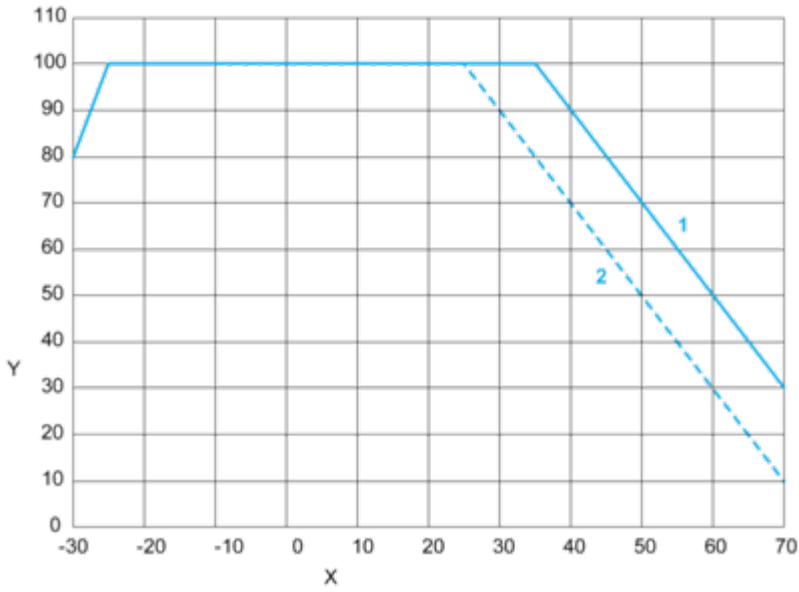

X : Surrounding Air Temperature (°C)

Y : Percentage of Max Load (%)

1 : Altitude 2000 m

2 : Altitude 5000 m

Note : < 100 VAC additional derating by 1.33% / VAC



