

veritas®

**Quick-Release
Tail Vise**

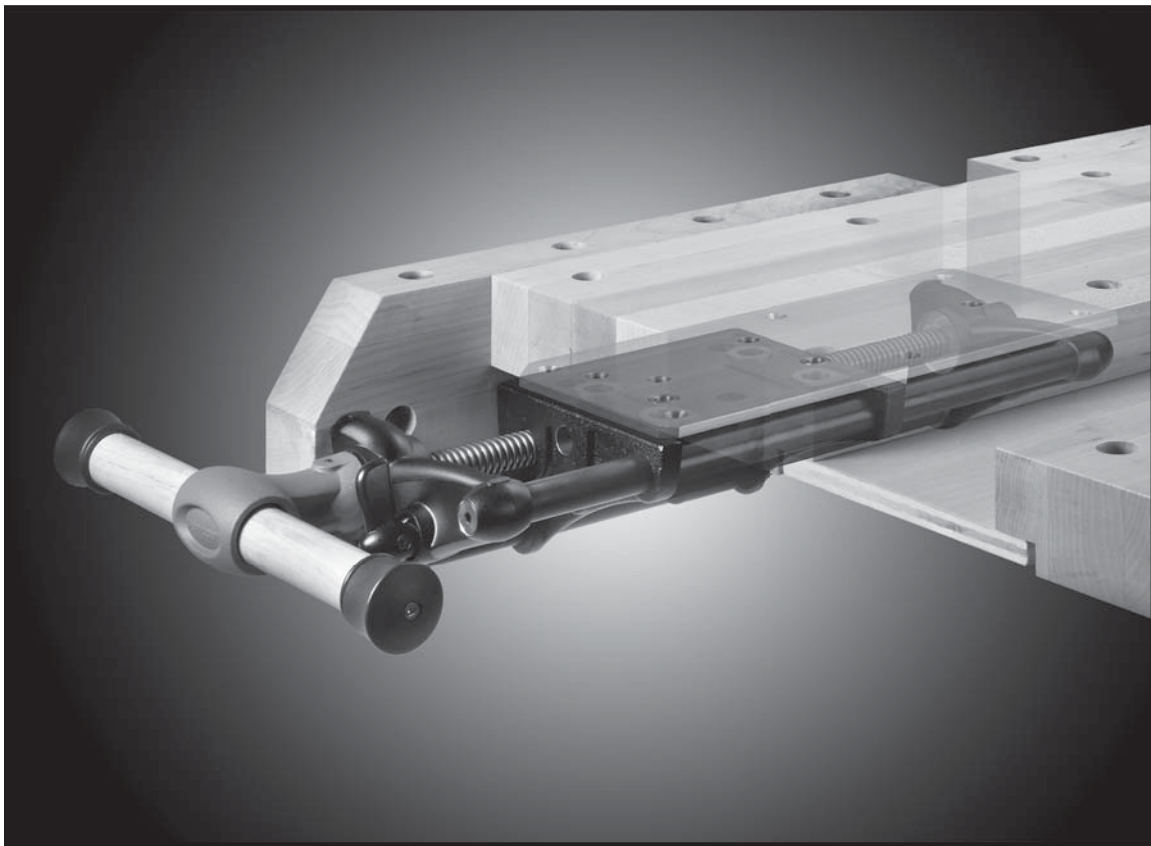

05G30.01

U.S. Des. Pat. No. D671,812

Introduction

The Veritas® Quick-Release Tail Vise is a reworked version of the well-known tail vise that is generally built into the front apron of many cabinetmaking workbenches. While workpieces can be clamped in the sliding jaw, the quick-release tail vise is primarily used in conjunction with bench dogs, either on top of the workbench or along the side of it.

The main problem with most sliding tail vises is that they require a significant amount of work to install them. Generally, retrofitting a tail vise onto an existing workbench requires extreme modifications to the workbench, and a new workbench that is to incorporate a sliding tail vise must be designed around the vise's mechanism.

The Veritas Quick-Release Tail Vise has been specifically designed to simplify the installation process. The vise mechanism is mounted onto the underside of a workbench top and a user-made jaw (e.g., a slab of material with dog holes) is attached to the mechanism.

This vise features a quick-release mechanism for fast adjustment of the opening. The positive action of the mechanism means the vise can be used for spreading workpieces apart, as well as for clamping them.

As delivered, the vise is configured for mounting on the right end of a workbench; however, it can easily be reconfigured for mounting on the left end of a workbench.

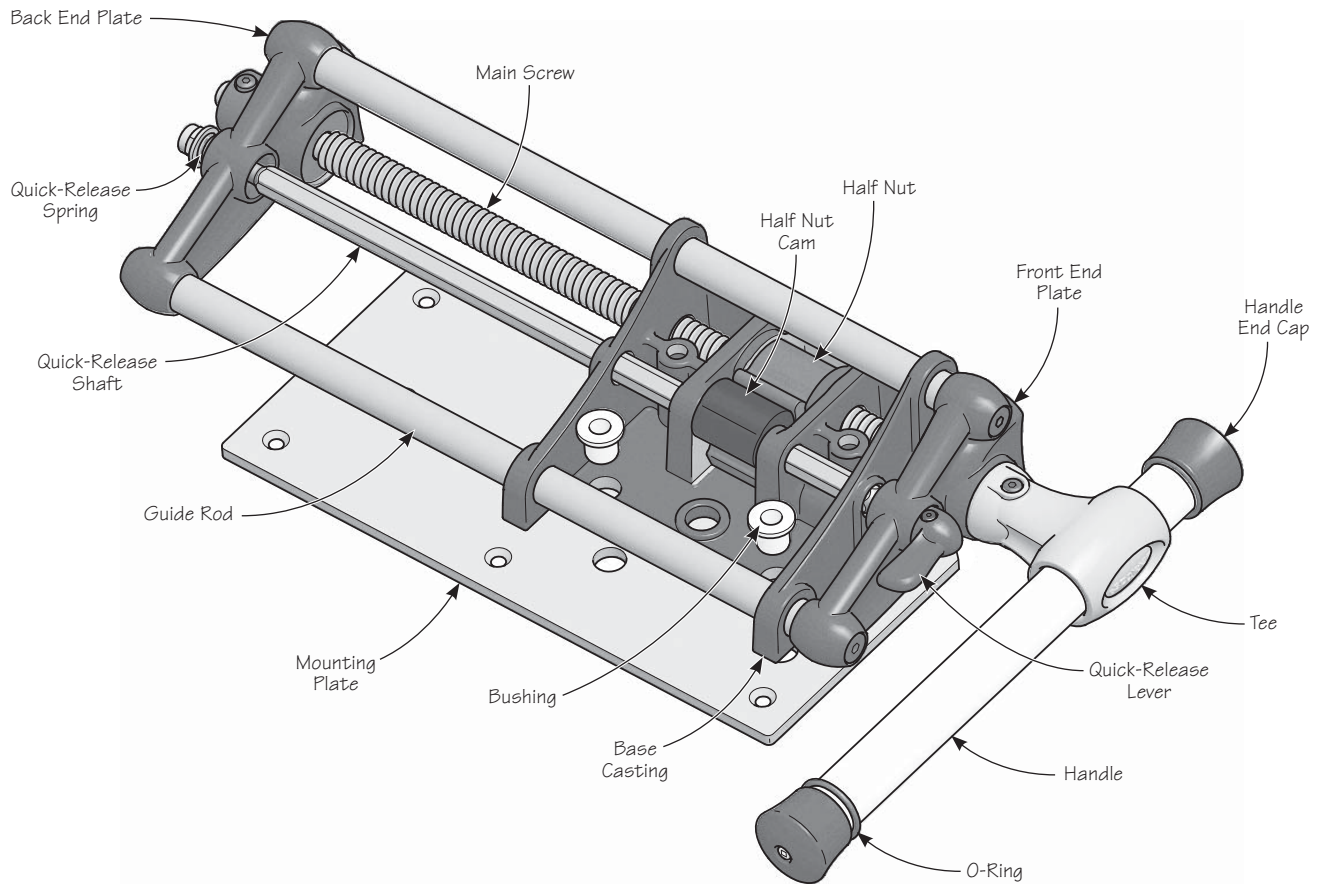

Figure 1: The Veritas® Quick-Release Tail Vise mechanism, shown upside down.

Requirements

Warning: Please read the instructions *before* you begin installing the quick-release tail vise onto your workbench. While the vise has been designed with ease of installation as a primary requirement, the instructions offer critical information to facilitate the task.

The quick-release tail vise should be mounted onto a workbench with a front apron. The mechanism requires a clear area, at least 17" × 6½", on the underside of the workbench top. The (user-made) jaw for the vise will make up part of the apron, so these two components will share dimensions.

The jaw/apron should be at least 3" deeper than the thickness of the workbench top. It should also be thick enough to accommodate a set of dog holes.

Preparing the Jaw

Figure 2 shows a jaw designed (with ¾" dog holes) to be mounted on the right end of a 2" thick workbench top.

Note 1: To reconfigure the vise for mounting on the left end of a workbench, remove the tee and attach it to the other end of the main shaft. Use a bit of masking tape across the half nut cam and half nut to maintain their relative orientation and then swap the quick-release lever and the quick-release spring.

Note 2a: If you are preparing a jaw for a workbench that is not 2" thick, use the **bold dimensions** shown on the (left) end view of **Figure 2** to vertically locate the mounting holes.

Note 2b: The bevelled cut on the right end of the jaw is optional and may be easier to determine after installation. The cut is configured so that the top edge of the jaw aligns with the top edge of the workbench (see **Figure 10**).

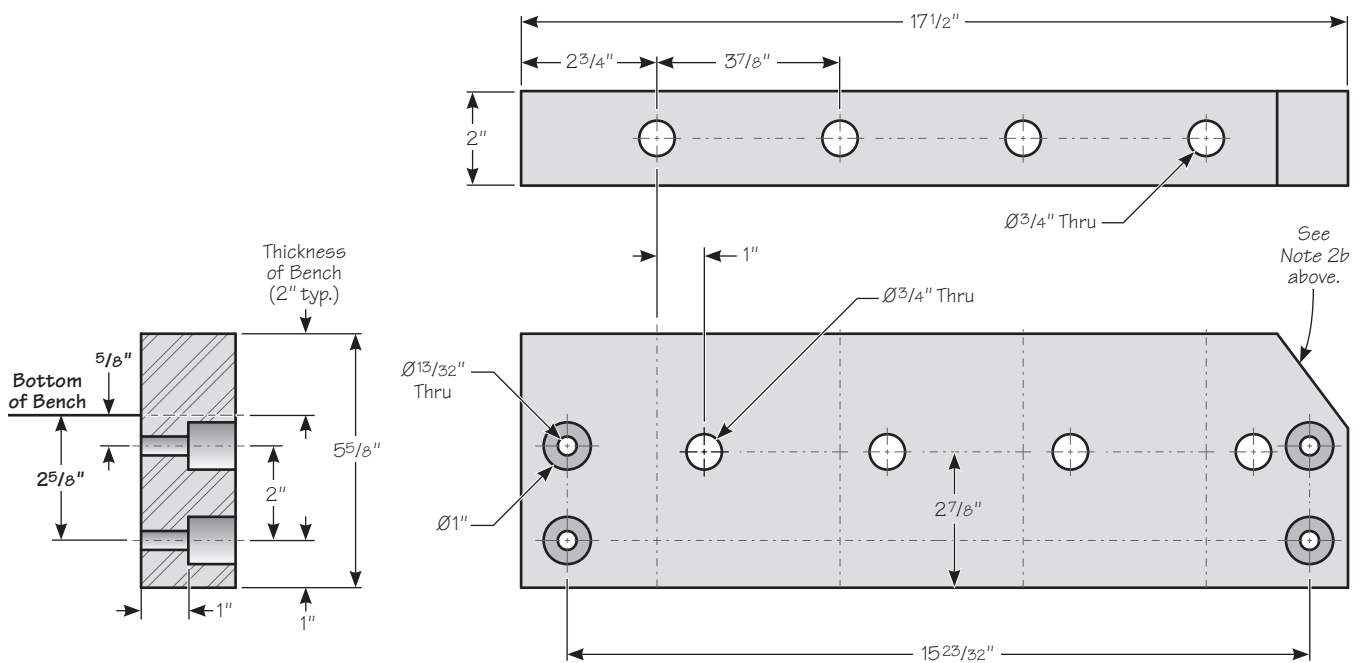

Figure 2: Dimensions for a standard jaw for a 2" thick workbench.

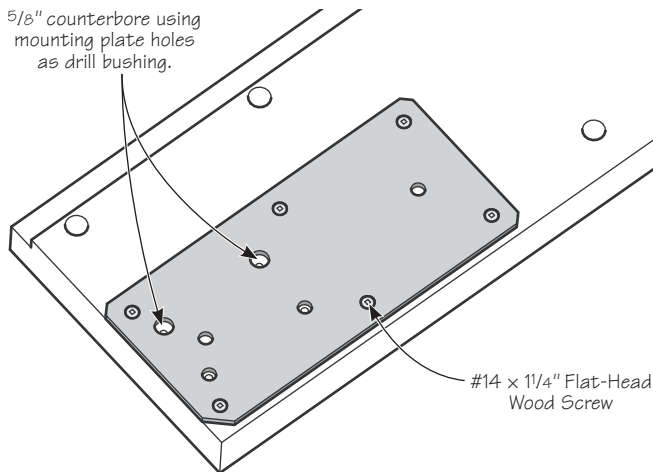

Figure 6: Installing the mounting plate and drilling bushing counterbores.

Use the mounting plate as a drill bushing, and drill a $\frac{5}{8}$ " diameter by approximately $\frac{1}{8}$ " deep counterbore in the bench top.

Drill pilot holes for the rear lag bolts, centered in the counterbores.

Caution: Be careful not to damage the mounting plate as you drill the bushing counterbores; otherwise, the bushings will be difficult to drive into place.

Position the assembled vise using the front lag screws, as shown in **Figure 7**. The lag screws should be tightened only enough to ensure the base casting is snug to the mounting plate. Check that the bushing holes in the base casting and the mounting plate align.

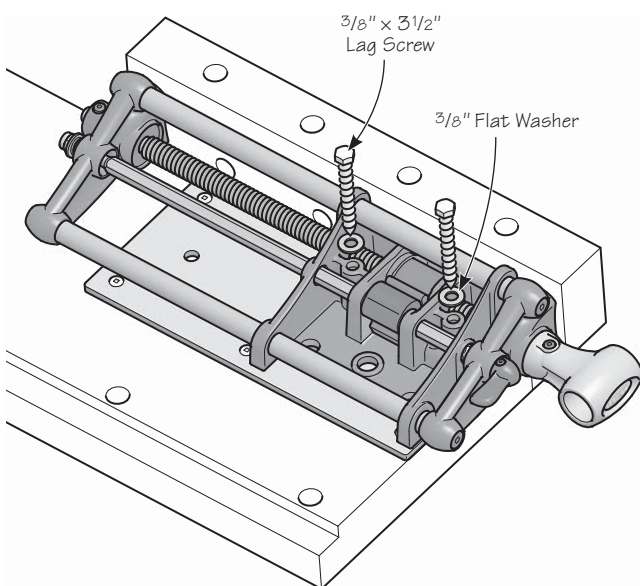

Figure 7: Installing front lag screws. Do not fully tighten the lag screws.

Drive the bushings through the base casting and mounting plate. This fit is extremely tight. If you need to use a hammer to drive the bushings into place, position a short length of wood between the bushing and the hammer to avoid damaging the rest of the mechanism. Install the rear lag screws and tighten all the lag screws.

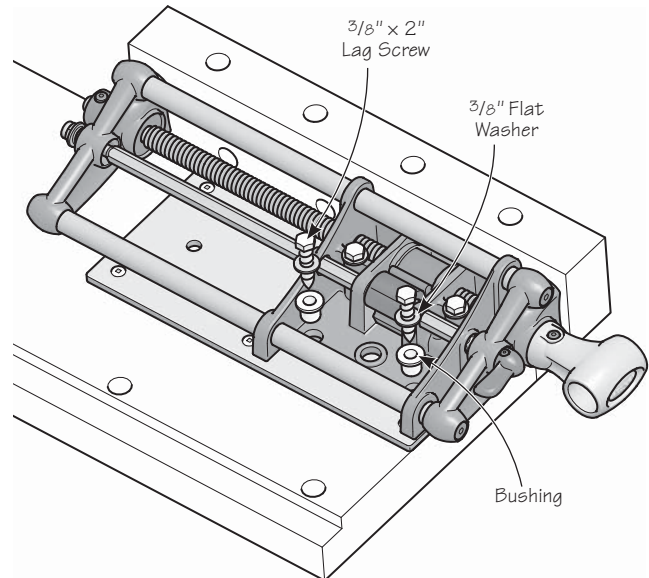

Figure 8: Installing the bushings and rear lag screws. Fully tighten all the lag screws.

Installing the Handle

Insert the handle into the tee, slide an O-ring onto each end of the handle, then attach the end caps with the #8 screws, as shown in **Figure 9**. (The O-rings will protect the end caps from banging into the tee as the handle is rotated.)

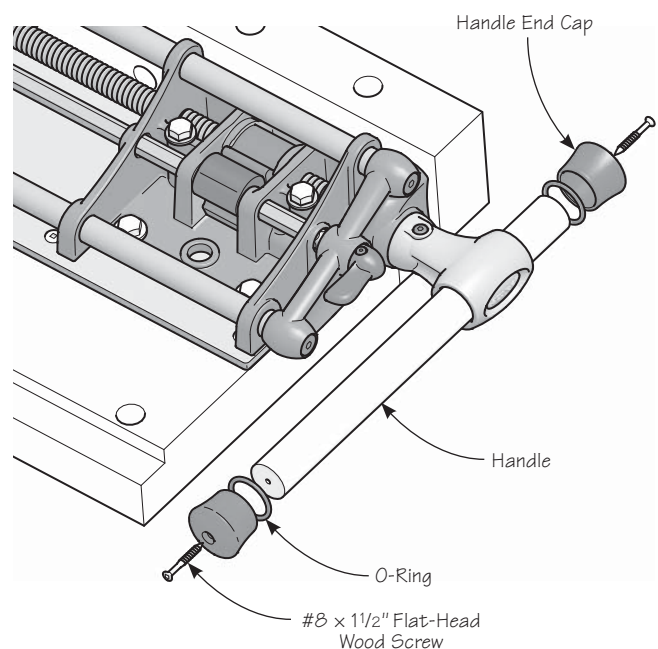

Figure 9: Installing the handle.

Testing the Installation and Installing the Apron

Release the jaw and test the mechanism to ensure the vise can travel fully without excessive binding. (Note that a bit of drag between the jaw and the workbench is acceptable.) If the vise binds, you can remove the jaw and lightly plane down the surface that contacts the bench top, or install shims between the jaw and the mechanism. Alternatively, you could lightly plane the edge of the bench.

Note: *Since the half nut is usually activated by gravity, the quick-release mechanism will not work while the bench is upside down. To test the motion of the vise, you will have to manually pull the half nut out of engagement.*

Flip the workbench back to its upright position. Back the vise off slightly (one or two turns) and install the apron so that the jaw clamps up to the apron before the vise uses its full travel.

Finishing Touches

Plane the front face of the jaw so that it is flush with the apron, and plane the top surface of the jaw and apron so that it is flush with the workbench top.

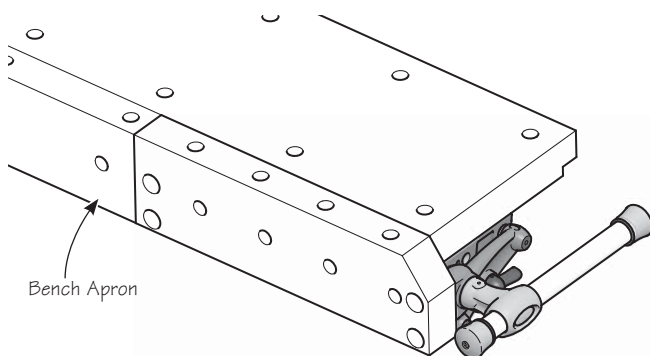

Figure 10: Installing the apron.

Apply the desired finish to the jaw and apron.

Use

This quick-release tail vise is a fairly simple device. Workpieces can be clamped between the jaw and the apron; however, it is more common to clamp workpieces between bench dogs, either on the top of the workbench or along the front of the bench, if appropriate dog holes have been drilled in the jaw/apron.

A novel feature of this vise is the quick-release half nut. To actuate, flip the quick-release lever from horizontal to vertical, as shown in **Figure 11**. (You may need to rotate the handle to release the threads.)

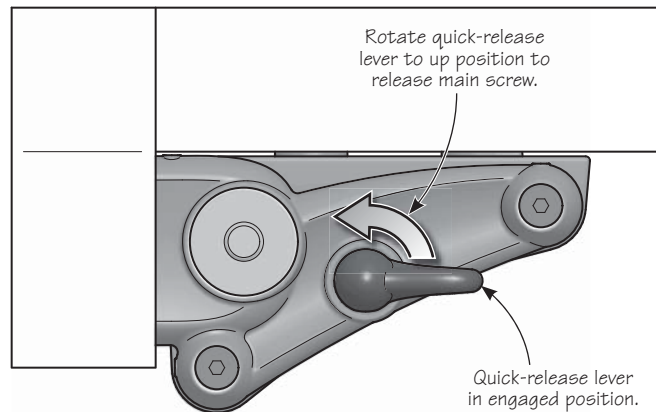

Figure 11: Releasing the half nut.

Caution: *Do not release the half nut when the vise is loaded.*

To re-engage the half nut, simply flip the lever back to horizontal. If the threads in the half nut are not aligned with those on the main screw, the lever may not return immediately to horizontal. If this is the case, you can align the threads by rotating the main screw; this will, in turn, force the quick-release spring to nudge the half nut into place, and snap the quick-release lever to horizontal.

Care and Maintenance

The vise comes fully lubricated; however, it will need periodic cleaning and lubrication. White grease on the main screw will ensure smooth operation, and a light oiling of the half nut will keep this component moving freely. The guide rods do not require lubrication; they have a surface treatment that is self-lubricating and prevents rust.

Note: *Do not use silicone-based lubricants on the main screw.*

veritas® Tools Inc.

814 Proctor Avenue
Ogdensburg NY 13669-2205
United States

1090 Morrison Drive
Ottawa ON K2H 1C2
Canada

customerservice@veritastools.com
www.veritastools.com