

Veritas® Poly-Gauge

(05N14.01)

Why Use the Poly-Gauge?

Originally designed to accurately set the fence of a jointer for the most common polygons, 4, 5, 6, 8 and 12-sided structures (e.g., boxes, multi-sided pots), the poly-gauge is equally useful with table saws, radial arm saws, bandsaws and drill presses for setting these same angles. It can be used to set miter gauges, blade tilts or table tilts, as well as serving for general layout work.

The poly-gauge can be used flat (e.g., for setting the miter gauge on a table saw) or the brass knob can be removed to become a stabilizing base that will hold the gauge perpendicular to a surface, leaving both your hands free for machine adjustment (e.g., when setting blade tilt on a table saw or fence tilt on a jointer).

Basic Procedures

The poly-gauge is easy to use and is quite foolproof if a few basic procedures are followed.

- The gauge-setting marked on the corners refers to the number of sides the figure has, rather than the included angle; if you want an eight-sided figure, you just use the corner marked "8".
- When you are using the poly-gauge in the vertical position, always ensure that it is at right angles to the fence or blade being set. If it is skewed, you will sacrifice accuracy.
- Be careful when setting saw blades that you rotate the blade (if necessary) to ensure that the gauge touches the body of the blade between two teeth rather than sitting against a tooth. The gauge has purposely been made narrow enough that this is possible on all current saw blades.
- Always make a test cut on a piece of scrap, because dynamic cuts are often different from static settings, particularly with radial arm saws.



Safety

It is advisable to disconnect the power when changing blades and when using the poly-gauge in case the motor is accidentally switched on.

Table Saws

Note that the table insert must be even with the top surface of the table. If the table insert is below the level of the table, a steel plate or a piece of plywood may be placed on the table to provide a level surface (see diagram).

To set the miter gauge:

Lay the poly-gauge on the level saw table with the angle you have chosen at the intersection of the saw blade and the miter gauge fence.

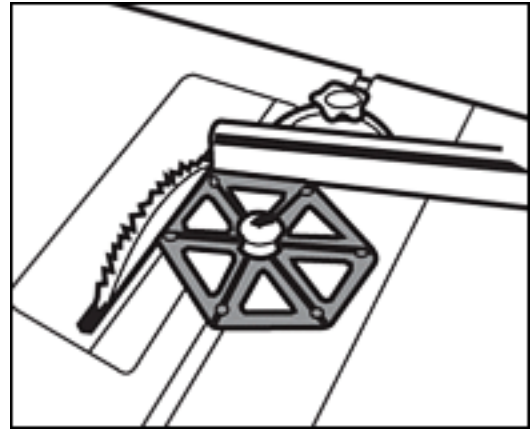

To set the table saw blade tilt:

1. To set the blade tilt accurately, the poly-gauge must be 90° to the blade.
2. Set the poly-gauge in position on the saw table with the slotted knob holding it upright and the angle you have chosen at the junction of the table and the saw blade.
3. Adjust the blade angle to match the poly-gauge. Be sure that the sides of the poly-gauge are touching both the saw blade and the table.
4. Lock the blade in position and check to be sure that the blade is still at the proper angle.

Jointers

The jointer fence is set in the same manner as table saw blade tilt.

Bandsaws

Bandsaws are set by tilting the table; the blade remains stationary.

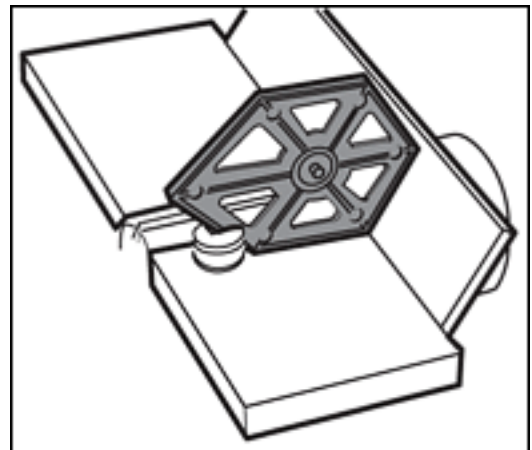

Drill Press

1. Place a 6" length of straight steel rod in the drill chuck. (Check straightness by rolling it on a flat surface such as the top of a table saw.)
2. Place the poly-gauge on the drill press table and tilt the table until the edge of the poly-gauge touches the steel rod (see diagram for bandsaws).

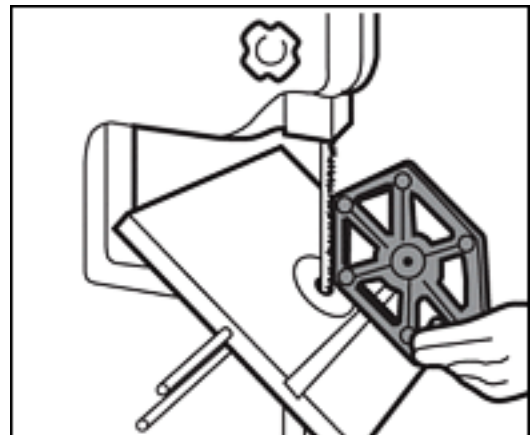

Radial Arm Saws

To set blade tilt:

1. Set the poly-gauge on the saw table with the slotted knob holding it upright.
2. Tilt the saw blade to align with the edge of the poly-gauge. **Note:** *If it is not possible to position the poly-gauge between the teeth of the blade, set it in position against a tooth and check the "line of light" for alignment. It is possible to gauge the parallelism of a narrow line of light to within 0.002" by eye.*
3. Lock the blade into place and check again for alignment.

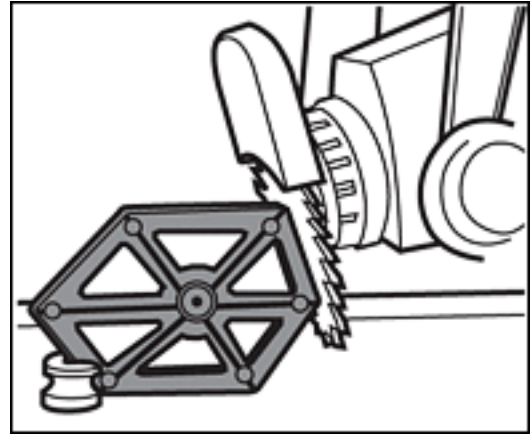

To set the cross-cut angle:

1. Lay the poly-gauge on a spacer (2" is about right) that lets the gauge touch the blade at a point wide enough not to interfere with the teeth. At the same time, lay one side of the gauge along the fence.
2. Adjust the swing as required, lock and check.

Using the Poly-Gauge for Layout

Turnings constructed from staves require the initial construction of a precisely joined polygon. The easiest way to establish your angles and dimensions is to use the poly-gauge and a compass to make the initial layout.

Draw a half circle with the diameter you want to turn. Align the poly-gauge on the diameter (AC) of the half circle with a corner (marked with the number of sides in your polygon) at the center point (B). Draw a radius line (BD) along the side of the poly-gauge from B to the circumference.

Draw a tangent to the circle at D. Draw another tangent to the circle at A. Draw a line from the intersection (E) of the two tangents to the center (B). You have now defined the typical joint of your polygon.

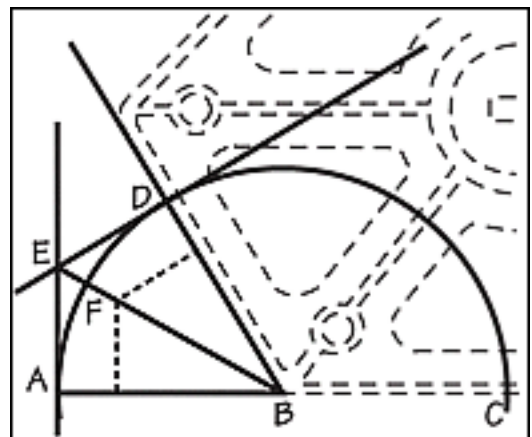

As a rule of thumb, the thickness of stock used should be at least double the length of EF. If you are limited to a supply of 1" thick material and EF is more than 1/2", you should consider increasing the number of sides of your polygon (e.g., from 6 to 8) or reducing the diameter to give you a stronger joint. If, on the other hand, you are using 2" thick material you may have a strong enough glue joint when EF is as long as 1-1/4" because of the greater thickness of the original stock.

The width of stock required for your polygon is double AE (or ED). Once again, you may find that you will have to reduce your diameter or increase the number of sides to accommodate the stock available to you.

©Copyright 1998 to 2008 by Lee Valley Tools Ltd. and Veritas® Tools Inc. All rights reserved.