

U.S. Des. Pat. D576,850

When preparing a workpiece, it can often be difficult to tell if it has any twist (or wind) along its length. Winding sticks accentuate the twist, making it much easier to identify and correct.

1. Place the two sticks as shown in **Figure 1**, such that the machined surfaces are facing each other and the edges of the sticks are at right angles to the side of the board. Typically, you would place the sticks at either end of the board; however, you may want to place them so that you can gauge the twist at different locations along the length of the board (see **Figure 2**).

2. Sight across the top edge of one stick toward the other. You should be looking over the black edge of the near stick toward the contrasting gray striped ridges along the top of the other stick. If the edges of the sticks are parallel to each other, then the board is not twisted. If you see a long gray wedge shape on the back, there is wind in the board.

Knowing that the grooves are 1/8" apart, it's easy to determine the amount of twist by counting the number of lines protruding above the edge of the near stick (see **Figure 3**). For relatively short boards, compare the number of visible lines protruding only over the width of the board. The difference will reveal the wind along the length of the board. For long boards, perspective errors may make it easier to count the lines at the ends of the winding sticks.

Measured this way, the twist will be a theoretical value over an 18" width. Actual board twist is a ratio between the board width and the length of the winding sticks (i.e., 18"). To calculate the actual twist for the particular board width, use the following equation:

$$T_a = T_m \times (W / 18)$$

Where: T_a = actual twist

T_m = measured twist

W = board width in inches

In the example shown in **Figure 3**, T_m is 1/4" and W is 8", so T_a would be just a little over 7/64".

$$T_a = T_m \times (W / 18)$$

$$= 1/4" \times (8"/18)$$

$$= 0.1111"$$

$$\approx 7/64"$$

3. Once you have determined any wind in the workpiece, mark the areas you need to rework.
4. Repeat steps 1 to 3 until the edges of the sticks are parallel to each other.

The winding sticks are designed to interlock so that the hanging holes align for easy storage.

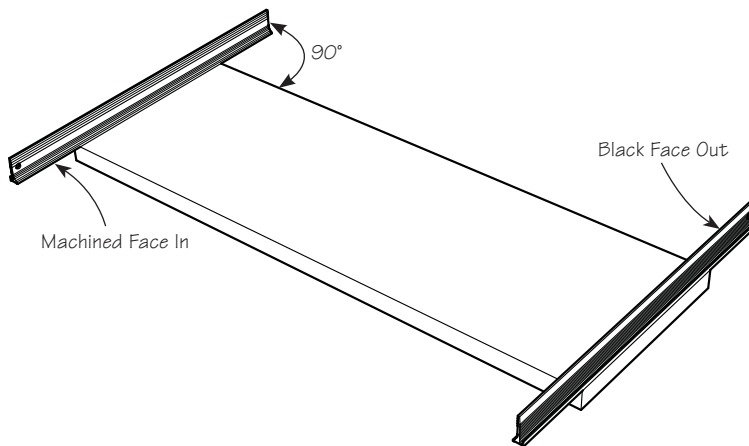

Figure 1: Setting up the winding sticks on a workpiece.

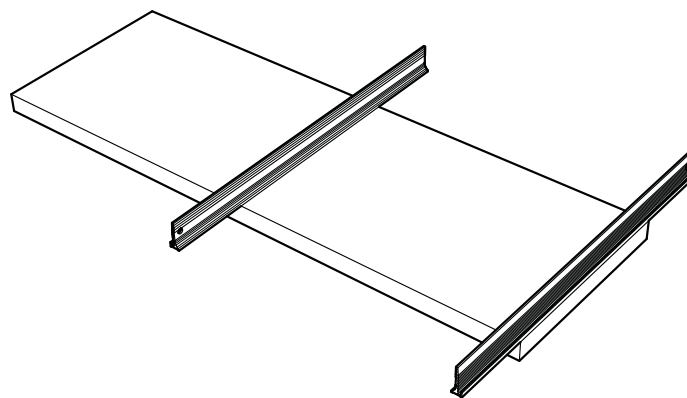

Figure 2: Measuring twist midway along a board.

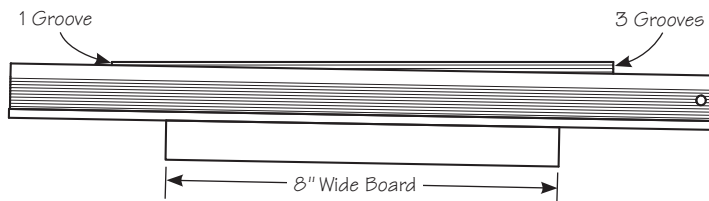

Figure 3: Measuring twist. In this case, the board is twisted by 1/4" across 18".

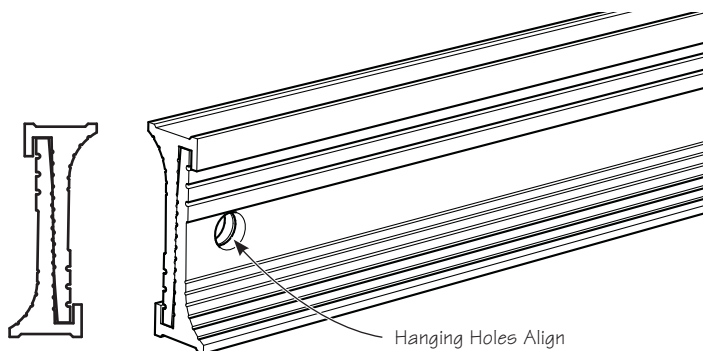

Figure 4: Sticks interlock for storage.