

Set Up the Polycom® EagleEye™ Producer

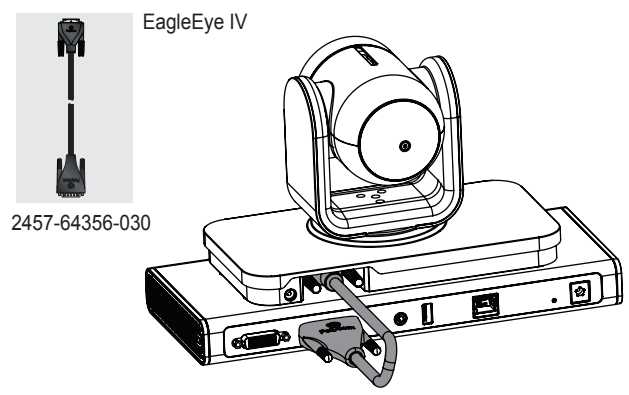

4 Polycom RealPresence® Group 300/310/500

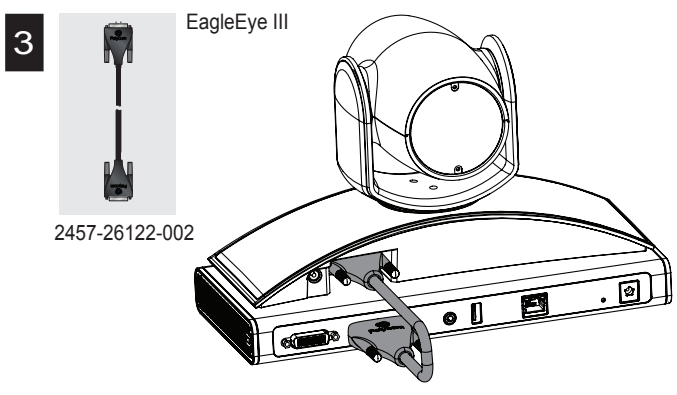
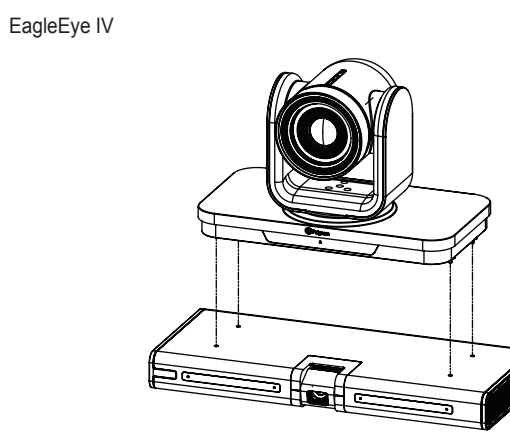
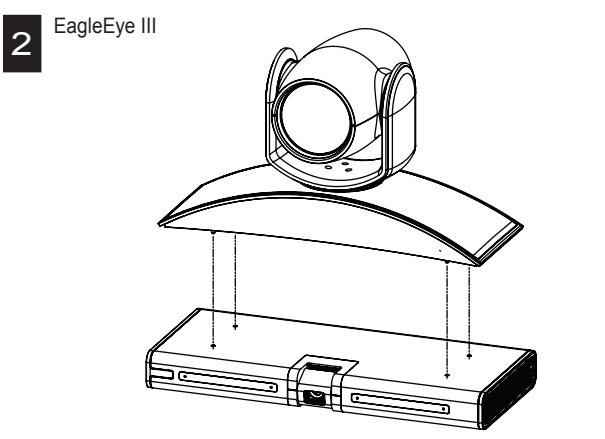
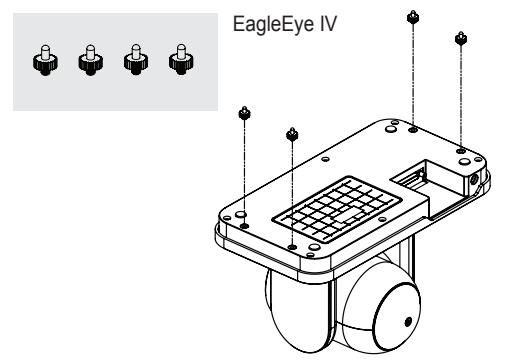
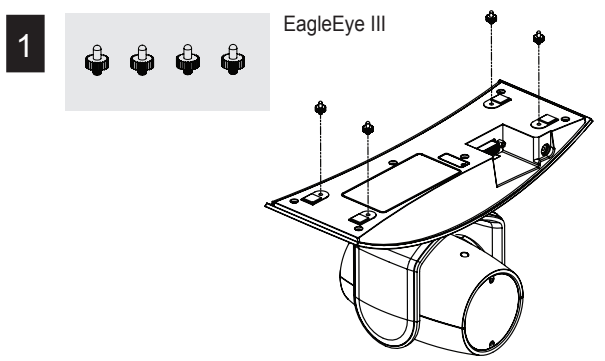
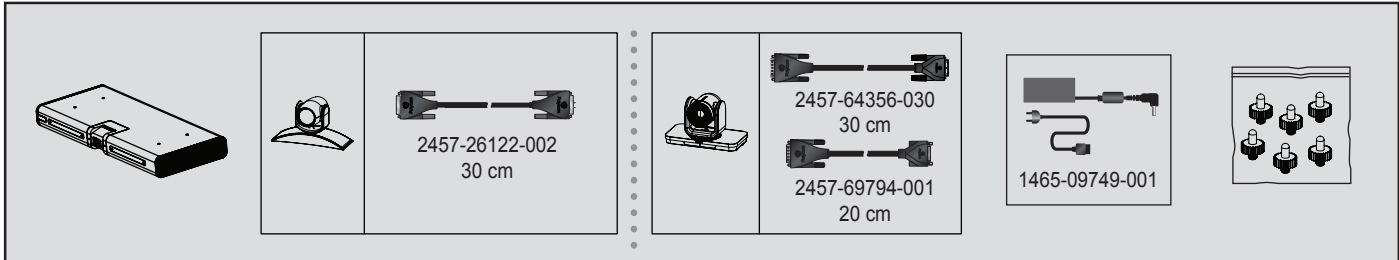
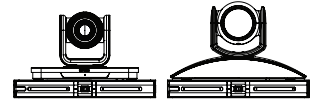
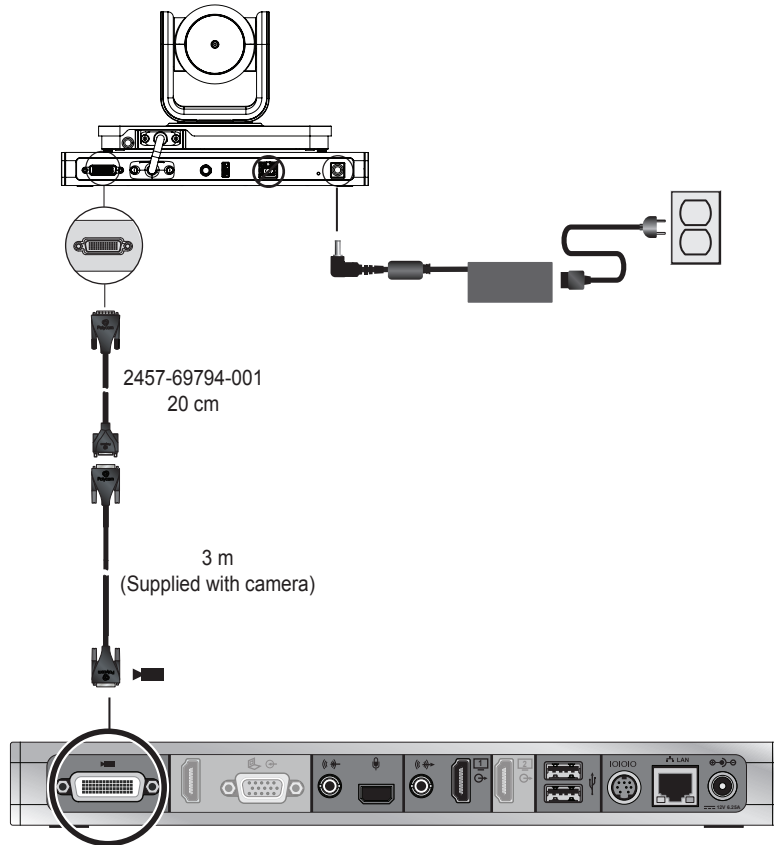
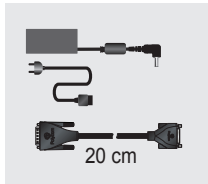
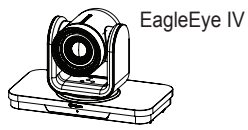
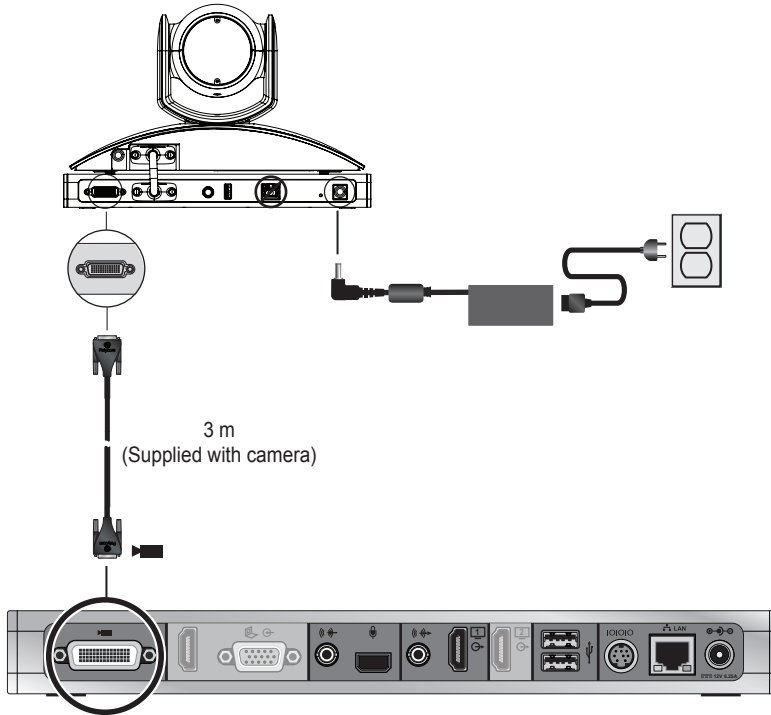
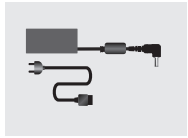
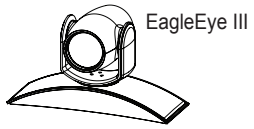

4 Polycom RealPresence® Group 700

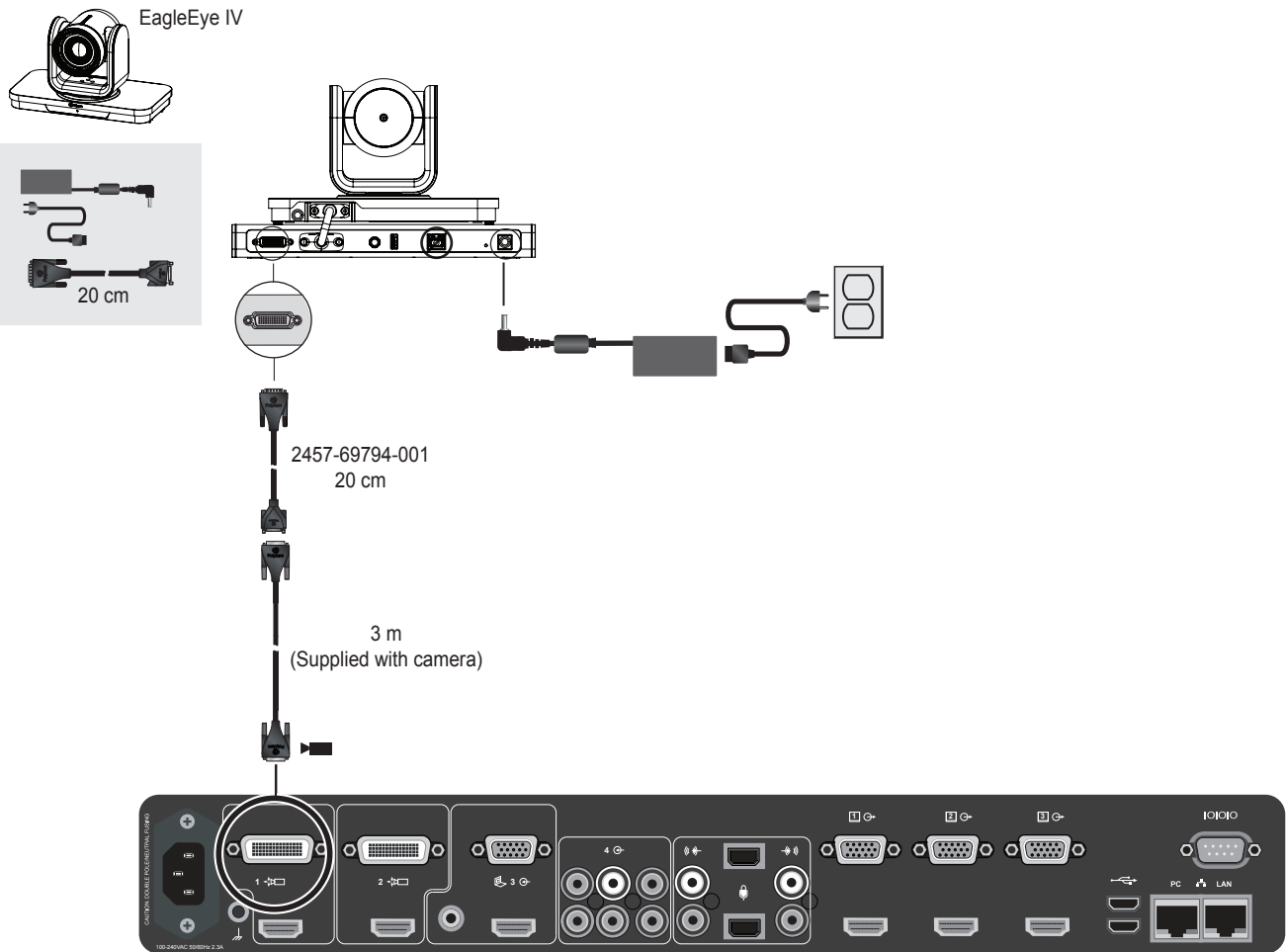
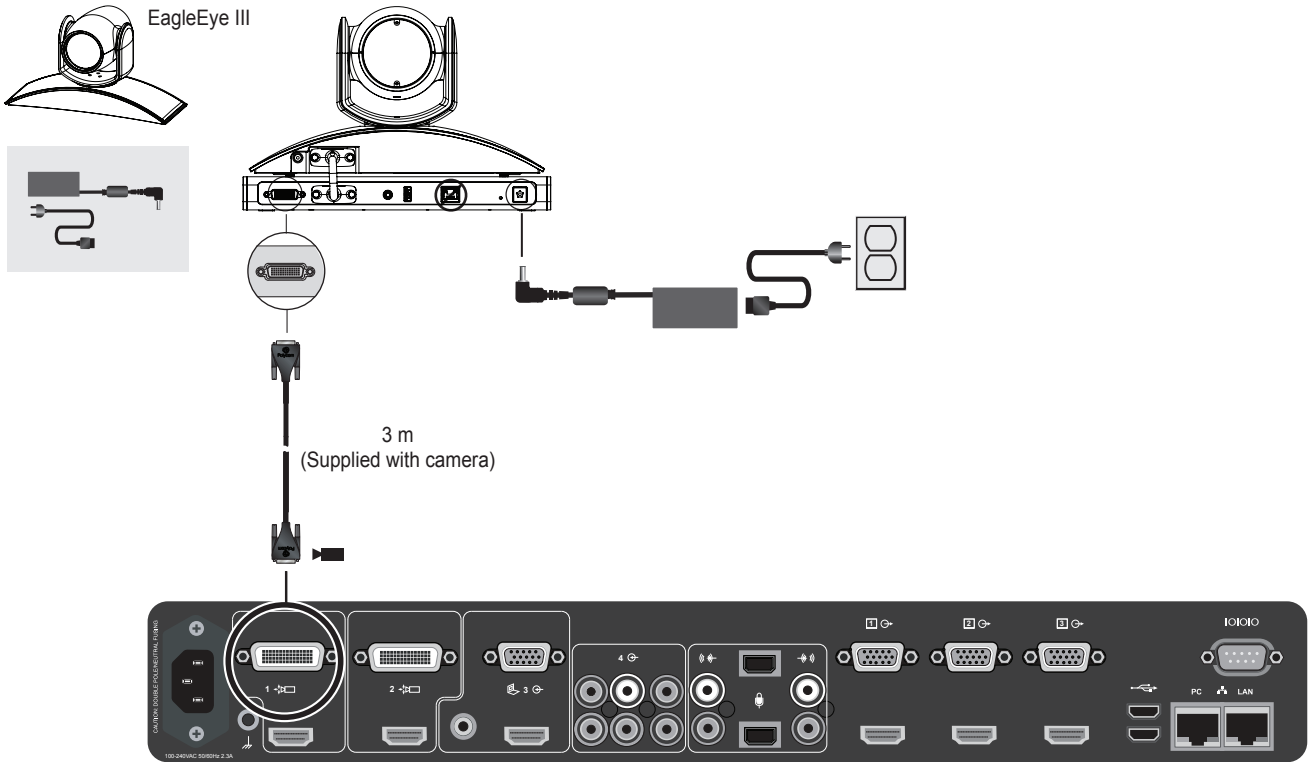

5

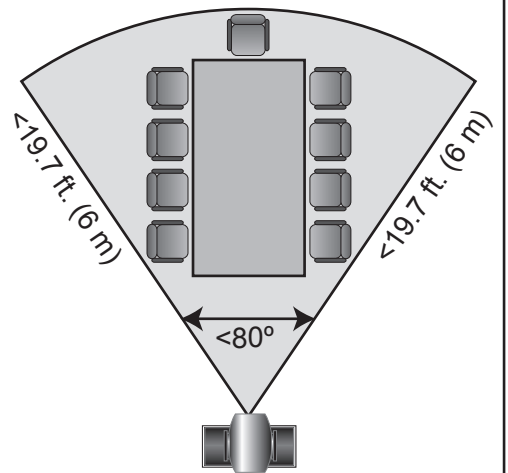
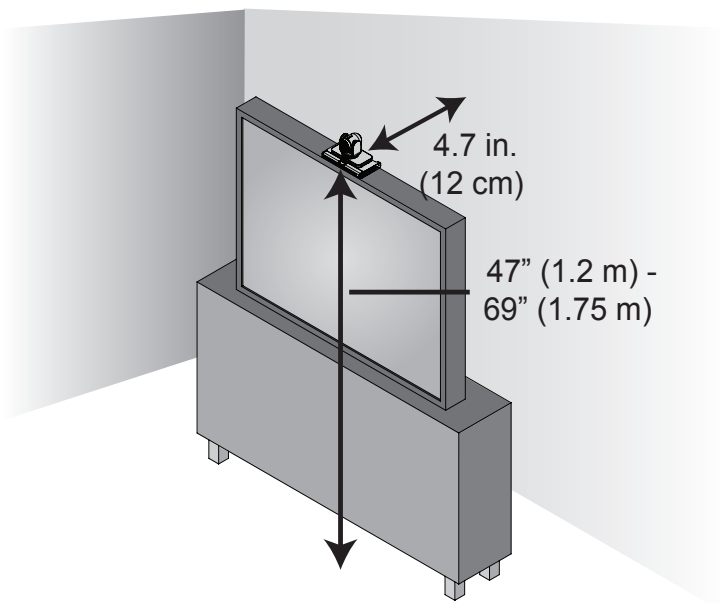
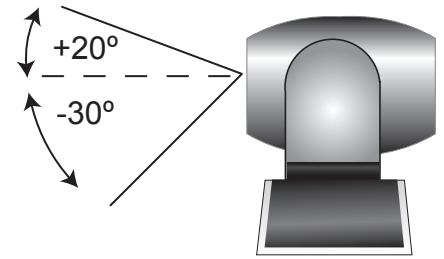
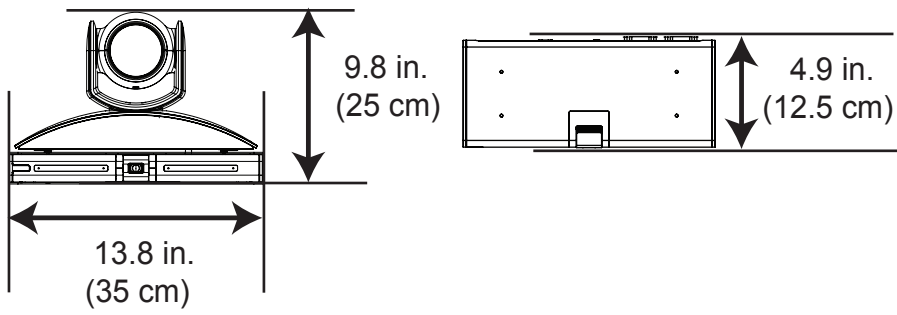

6

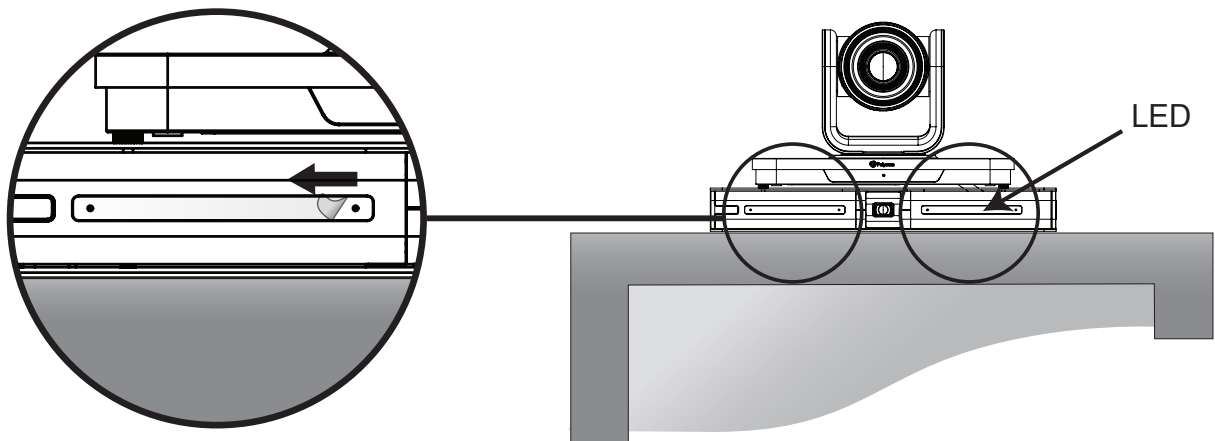

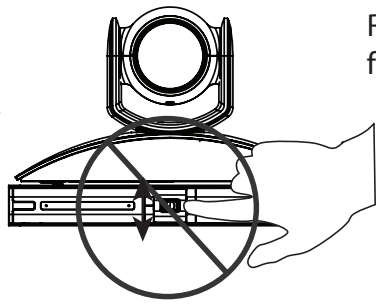

Refer to the Polycom EagleEye Producer User Guide for more information.

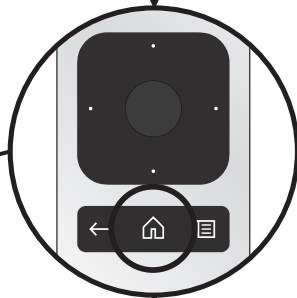
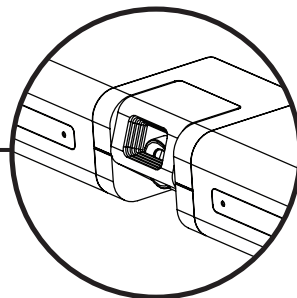
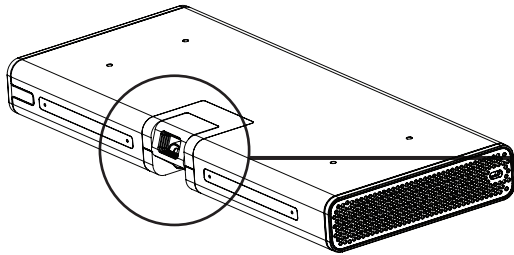

1 ⏶ 5 seconds
LED: fast blue blink

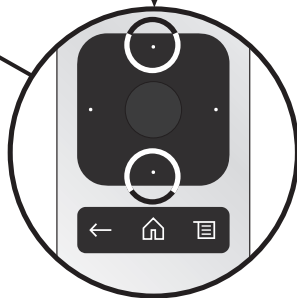

2

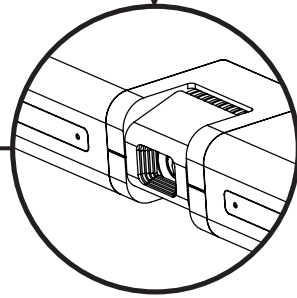
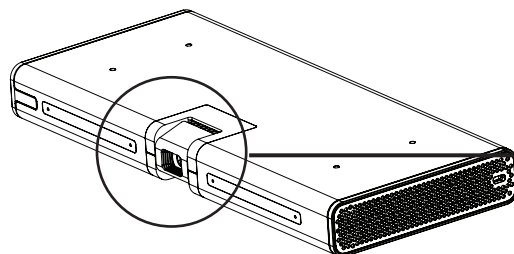

3 To exit ⏶ press any key on remote except up/down arrows. LED: blue

