

Pipe Fittings



FITOK Group

FITOK GmbH (Headquarter)

Sprendlinger Landstr. 115, 63069 Offenbach am Main, Germany
Tel.: +49 69 8900 4498 Fax: +49 69 8900 4495

FITOK, Inc.

13843 North Promenade Blvd., Suite 750, Stafford, Texas 77477, USA
Tel.: +1 281 888 0077 Fax: +1 281 582 4051

FITOK Incorporated

1-4F, Block C, Zone E, Yingtailong Industrial Park, Dalang Street,
Longhua District, Shenzhen, 518109, China
Tel.: +86 755 2803 2500 Fax: +86 755 2803 2619

FITOK Middle East Oil Equipment Trading LLC

208-209, Makateb Tower, Airport Road, P.O.Box 185412, Deira, Dubai, UAE
Tel.: +971 4 2959 853 Fax: +971 4 2959 854

info@fitokgroup.com
www.fitokgroup.com

FK-IC-HF-04-EN-151027

FITOK
Valves and Fittings

www.fitokgroup.com

Contents

Pipe Plugs - HPP



Hex Nipples - HPHN



Hex Long Nipples - HPLN



Pipe Caps - HPC



Pipe Caps Assembly(Moveable Insert)-HMC



Hex Couplings - HPCG



Zero-Clearance Unions - HPZC



Adapters - HPA



Male Elbows - HPME

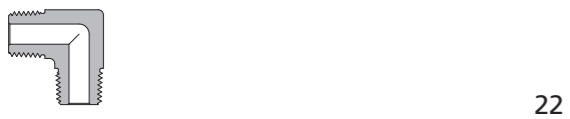

Street Elbows - HPSE

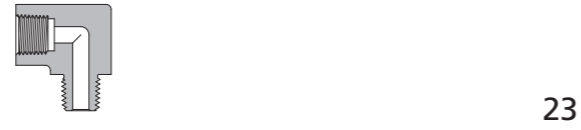

Female Elbows - HPE



Male Tees - HPMT



Male Street Tees - HPST

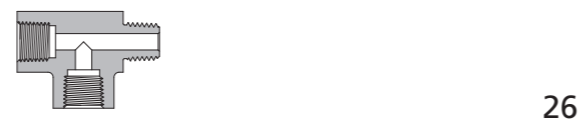

Male Branch Tees - HPBT



Female Tees - HPT



Female Crosses - HPCR



Features

- ⦿ The hardened threads with smooth surface finishing avoid galling and help to extend the fitting service life.
- ⦿ Radius junction design with elbows provides smooth flow path.
- ⦿ Every fitting is stamped with size, material and heat code.
- ⦿ 316 stainless steel is standard material. Other materials are available upon request.

Thread Specifications

Connection Type	Code	Thread Type	Thread Specification
NPT	NS	NPT	ASME B1.20.1, SAE AS71051
ISO Tapered	RT	ISO Tapered	ISO 7-1, BS EN 10226-1, JIS B0203
Heavy-Duty SAE/MS (Accordance with SAE J1926-2)	SH	SAE/MS	ASME B1.1
O-ring Seal SAE/MS (Accordance with SAE J1926-1)	US		
JIC (37° Flare)	AN		
JIC(37°Flare)Female Swivel	AS		
Type "M" Male	HM		

Working Temperature

Connection Type	Temperature Rating
NPT	-325°F to 400°F (-198°C to 204°C)
ISO Tapered	-325°F to 400°F (-198°C to 204°C)
Heavy-Duty SAE/MS (Accordance with SAE J1926-2)	0°F to 400°F (-17.8°C to 204°C)
O-ring Seal SAE/MS (Accordance with SAE J1926-1)	0°F to 400°F (-17.8°C to 204°C)
JIC (37° Flare)	-423°F to 1200°F (-252°C to 649°C)
JIC(37°Flare)Female swivel	-423°F to 1200°F (-252°C to 649°C)
Type "M" Male	-423°F to 1200°F (-252°C to 649°C)

Working Pressure

The working pressures of pipe fittings are shown in the ordering information table.

Elevated Temperature Factors

To get the maximum working pressure at elevated temperature, use the maximum working pressure at ambient temperature to multiply the factors in the table below.

Material	Temperature		Factor
	°F	°C	
316	100	38	1
	200	93	1
	300	149	1
	400	204	0.97
	500	260	0.90
	600	316	0.85
	700	371	0.82
800	427	0.80	

Data in this table is applied only to the working temperature below 800°F (427°C). For the working temperature above 800°F (427°C), please consult FITOK Group, then we will provide you relative solutions.

Caution:

- Do not loosen or tighten fittings under pressure.
- Always use proper thread sealants on tapered pipe threads.

Pipe Plugs

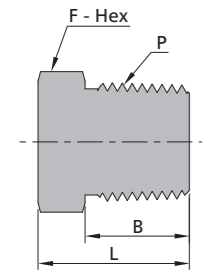

Male NPT Threads					
P-NPT Size	Ordering Number	Dimension, in. (mm)			Working Pressure psig (bar)
		L	F	B	
1/8	SS-HPP-NS2	0.63 (16.0)	0.44 (11.1)	0.38 (9.7)	15000 (1034)
1/4	SS-HPP-NS4	0.87 (22.2)	0.56 (14.3)	0.56 (14.2)	15000 (1034)
3/8	SS-HPP-NS6	0.93 (23.6)	0.69 (17.5)	0.56 (14.2)	15000 (1034)
1/2	SS-HPP-NS8	1.16 (29.5)	0.87 (22.2)	0.75 (19.1)	15000 (1034)
3/4	SS-HPP-NS12	1.25 (31.8)	1.06 (27.0)	0.75 (19.1)	10000 (690)
1	SS-HPP-NS16	1.55 (39.3)	1.37 (34.9)	0.94 (23.9)	10000 (690)

Male ISO Tapered Threads					
P-ISO Tapered Size	Ordering Number	Dimension, in. (mm)			Working Pressure psig (bar)
		L	F	B	
1/8	SS-HPP-RT2	0.63 (16.0)	0.44 (11.1)	0.38 (9.7)	15000 (1034)
1/4	SS-HPP-RT4	0.87 (22.2)	0.56 (14.3)	0.56 (14.2)	15000 (1034)
3/8	SS-HPP-RT6	0.93 (23.6)	0.69 (17.5)	0.56 (14.2)	15000 (1034)
1/2	SS-HPP-RT8	1.16 (29.5)	0.87 (22.2)	0.75 (19.1)	15000 (1034)
3/4	SS-HPP-RT12	1.25 (31.8)	1.06 (27.0)	0.75 (19.1)	10000 (690)
1	SS-HPP-RT16	1.55 (39.3)	1.37 (34.9)	0.94 (23.9)	10000 (690)

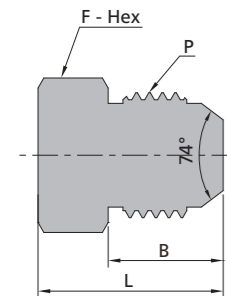

Male JIC					
P-SAE/MS Thread Size	Ordering Number	Dimension, in. (mm)			Working Pressure psig (bar)
		L	F	B	
7/16-20	SS-HPP-AN4	0.83 (21.0)	0.50 (12.7)	0.55 (14.0)	20000 (1379)
9/16-18	SS-HPP-AN6	0.89 (22.7)	0.63 (15.9)	0.56 (14.1)	20000 (1379)
3/4-16	SS-HPP-AN8	1.05 (26.7)	0.81 (20.6)	0.66 (16.7)	20000 (1379)
7/8-14	SS-HPP-AN10	1.19 (30.3)	0.94 (23.8)	0.76 (19.3)	20000 (1379)
1 1/16-12	SS-HPP-AN12	1.37 (34.9)	1.13 (28.6)	0.86 (21.9)	15000 (1034)
1 5/16-12	SS-HPP-AN16	1.51 (38.3)	1.37 (34.9)	0.91 (23.1)	15000 (1034)

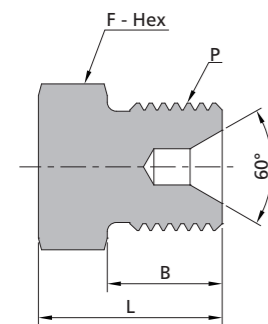

Type "M" Male					
P-SAE/MS Thread Size	Ordering Number	Dimension, in. (mm)			Working Pressure psig (bar)
		L	F	B	
9/16-18	SS-HPP-HM9	0.84 (21.3)	0.63 (15.9)	0.50 (12.7)	60000 (4137)
3/4-16	SS-HPP-HM12	1.01 (25.6)	0.75 (19.1)	0.63 (16.0)	30000 (2068)
7/8-14	SS-HPP-HM14	1.21 (30.8)	1.00 (25.4)	0.76 (19.2)	50000 (3447)
1-12	SS-HPP-HM16	1.10 (27.9)	1.00 (25.4)	0.64 (16.3)	30000 (2068)
1 5/16-12	SS-HPP-HM21	1.22 (30.9)	1.37 (34.9)	0.62 (15.7)	20000 (1379)

Hex Nipples

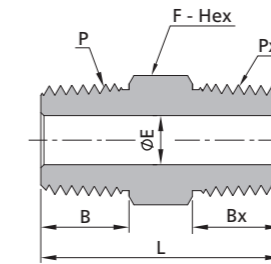

Male NPT Threads								
P-NPT Size	Px-NPT Size	Ordering Number	Dimension, in. (mm)					Working Pressure psig (bar)
			L	F	B	Bx	E	
1/8	1/8	SS-HPHN-NS2	1.05 (26.6)	0.44 (11.1)	0.38 (9.7)	0.38 (9.7)	0.19 (4.8)	15000 (1034)
1/4	1/8	SS-HPHN-NS4-NS2	1.30 (32.9)	0.56 (14.3)	0.56 (14.2)	0.38 (9.7)	0.19 (4.8)	15000 (1034)
1/4	1/4	SS-HPHN-NS4	1.47 (37.4)	0.56 (14.3)	0.56 (14.2)	0.56 (14.2)	0.25 (6.4)	15000 (1034)
3/8	1/8	SS-HPHN-NS6-NS2	1.34 (34.1)	0.69 (17.5)	0.56 (14.2)	0.38 (9.7)	0.19 (4.8)	15000 (1034)
3/8	1/4	SS-HPHN-NS6-NS4	1.52 (38.6)	0.69 (17.5)	0.56 (14.2)	0.56 (14.2)	0.25 (6.4)	15000 (1034)
3/8	3/8	SS-HPHN-NS6	1.52 (38.6)	0.69 (17.5)	0.56 (14.2)	0.56 (14.2)	0.31 (7.9)	15000 (1034)
1/2	1/8	SS-HPHN-NS8-NS2	1.58 (40.2)	0.87 (22.2)	0.75 (19.1)	0.38 (9.7)	0.19 (4.8)	15000 (1034)
1/2	1/4	SS-HPHN-NS8-NS4	1.76 (44.7)	0.87 (22.2)	0.75 (19.1)	0.56 (14.2)	0.25 (6.4)	15000 (1034)
1/2	3/8	SS-HPHN-NS8-NS6	1.76 (44.7)	0.87 (22.2)	0.75 (19.1)	0.56 (14.2)	0.31 (7.9)	15000 (1034)
1/2	1/2	SS-HPHN-NS8	1.95 (49.6)	0.87 (22.2)	0.75 (19.1)	0.75 (19.1)	0.38 (9.6)	15000 (1034)
3/4	1/8	SS-HPHN-NS12-NS2	1.67 (42.4)	1.06 (27.0)	0.75 (19.1)	0.38 (9.7)	0.22 (5.5)	10000 (690)
3/4	1/4	SS-HPHN-NS12-NS4	1.85 (46.9)	1.06 (27.0)	0.75 (19.1)	0.56 (14.2)	0.28 (7.1)	10000 (690)
3/4	3/8	SS-HPHN-NS12-NS6	1.85 (46.9)	1.06 (27.0)	0.75 (19.1)	0.56 (14.2)	0.38 (9.6)	10000 (690)
3/4	1/2	SS-HPHN-NS12-NS8	2.04 (51.8)	1.06 (27.0)	0.75 (19.1)	0.75 (19.1)	0.47 (11.9)	10000 (690)
3/4	3/4	SS-HPHN-NS12	2.04 (51.8)	1.06 (27.0)	0.75 (19.1)	0.75 (19.1)	0.58 (14.8)	10000 (690)
1	1/8	SS-HPHN-NS16-NS2	1.96 (49.8)	1.37 (34.9)	0.94 (23.9)	0.38 (9.7)	0.22 (5.5)	10000 (690)
1	1/4	SS-HPHN-NS16-NS4	2.14 (54.3)	1.37 (34.9)	0.94 (23.9)	0.56 (14.2)	0.28 (7.1)	10000 (690)
1	3/8	SS-HPHN-NS16-NS6	2.14 (54.3)	1.37 (34.9)	0.94 (23.9)	0.56 (14.2)	0.38 (9.6)	10000 (690)
1	1/2	SS-HPHN-NS16-NS8	2.33 (59.2)	1.37 (34.9)	0.94 (23.9)	0.75 (19.1)	0.47 (11.9)	10000 (690)
1	3/4	SS-HPHN-NS16-NS12	2.33 (59.2)	1.37 (34.9)	0.94 (23.9)	0.75 (19.1)	0.58 (14.8)	10000 (690)
1	1	SS-HPHN-NS16	2.52 (64.0)	1.37 (34.9)	0.94 (23.9)	0.94 (23.9)	0.79 (20.0)	10000 (690)

Hex Nipples

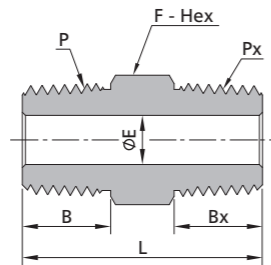

Male NPT Threads			Male ISO Tapered Threads					
P-NPT Size	Px-ISO Tapered Size	Ordering Number	Dimension, in. (mm)					Working Pressure psig (bar)
			L	F	B	Bx	E	
1/8	1/8	SS-HPHN-NS2-RT2	1.05 (26.6)	0.44 (11.1)	0.38 (9.7)	0.38 (9.7)	0.19 (4.8)	15000 (1034)
1/4	1/8	SS-HPHN-NS4-RT2	1.30 (32.9)	0.56 (14.3)	0.56 (14.2)	0.38 (9.7)	0.19 (4.8)	15000 (1034)
1/4	1/4	SS-HPHN-NS4-RT4	1.47 (37.4)	0.56 (14.3)	0.56 (14.2)	0.56 (14.2)	0.25 (6.4)	15000 (1034)
3/8	1/8	SS-HPHN-NS6-RT2	1.34 (34.1)	0.69 (17.5)	0.56 (14.2)	0.38 (9.7)	0.19 (4.8)	15000 (1034)
3/8	1/4	SS-HPHN-NS6-RT4	1.52 (38.6)	0.69 (17.5)	0.56 (14.2)	0.56 (14.2)	0.25 (6.4)	15000 (1034)
3/8	3/8	SS-HPHN-NS6-RT6	1.52 (38.6)	0.69 (17.5)	0.56 (14.2)	0.56 (14.2)	0.31 (7.9)	15000 (1034)
1/2	1/8	SS-HPHN-NS8-RT2	1.58 (40.2)	0.87 (22.2)	0.75 (19.1)	0.38 (9.7)	0.19 (4.8)	15000 (1034)
1/2	1/4	SS-HPHN-NS8-RT4	1.76 (44.7)	0.87 (22.2)	0.75 (19.1)	0.56 (14.2)	0.25 (6.4)	15000 (1034)
1/2	3/8	SS-HPHN-NS8-RT6	1.76 (44.7)	0.87 (22.2)	0.75 (19.1)	0.56 (14.2)	0.31 (7.9)	15000 (1034)
1/2	1/2	SS-HPHN-NS8-RT8	1.95 (49.6)	0.87 (22.2)	0.75 (19.1)	0.75 (19.1)	0.38 (9.6)	15000 (1034)
3/4	1/8	SS-HPHN-NS12-RT2	1.67 (42.4)	1.06 (27.0)	0.75 (19.1)	0.38 (9.7)	0.22 (5.5)	10000 (690)
3/4	1/4	SS-HPHN-NS12-RT4	1.85 (46.9)	1.06 (27.0)	0.75 (19.1)	0.56 (14.2)	0.28 (7.1)	10000 (690)
3/4	3/8	SS-HPHN-NS12-RT6	1.85 (46.9)	1.06 (27.0)	0.75 (19.1)	0.56 (14.2)	0.38 (9.6)	10000 (690)
3/4	1/2	SS-HPHN-NS12-RT8	2.04 (51.8)	1.06 (27.0)	0.75 (19.1)	0.75 (19.1)	0.47 (11.9)	10000 (690)
3/4	3/4	SS-HPHN-NS12-RT12	2.04 (51.8)	1.06 (27.0)	0.75 (19.1)	0.75 (19.1)	0.58 (14.8)	10000 (690)
1	1/8	SS-HPHN-NS16-RT2	1.96 (49.8)	1.37 (34.9)	0.94 (23.9)	0.38 (9.7)	0.22 (5.5)	10000 (690)
1	1/4	SS-HPHN-NS16-RT4	2.14 (54.3)	1.37 (34.9)	0.94 (23.9)	0.56 (14.2)	0.28 (7.1)	10000 (690)
1	3/8	SS-HPHN-NS16-RT6	2.14 (54.3)	1.37 (34.9)	0.94 (23.9)	0.56 (14.2)	0.38 (9.6)	10000 (690)
1	1/2	SS-HPHN-NS16-RT8	2.33 (59.2)	1.37 (34.9)	0.94 (23.9)	0.75 (19.1)	0.47 (11.9)	10000 (690)
1	3/4	SS-HPHN-NS16-RT12	2.33 (59.2)	1.37 (34.9)	0.94 (23.9)	0.75 (19.1)	0.58 (14.8)	10000 (690)
1	1	SS-HPHN-NS16-RT16	2.52 (64.0)	1.37 (34.9)	0.94 (23.9)	0.94 (23.9)	0.79 (20.0)	10000 (690)

Hex Nipples

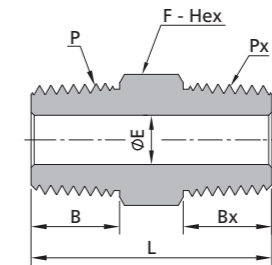

Male ISO Tapered Threads			Male ISO Tapered Threads					
P-ISO Tapered Size	Px-ISO Tapered Size	Ordering Number	Dimension, in. (mm)					Working Pressure psig (bar)
			L	F	B	Bx	E	
1/8	1/8	SS-HPHN-RT2	1.05 (26.6)	0.44 (11.1)	0.38 (9.7)	0.38 (9.7)	0.19 (4.8)	15000 (1034)
1/4	1/8	SS-HPHN-RT4-RT2	1.30 (32.9)	0.56 (14.3)	0.56 (14.2)	0.38 (9.7)	0.19 (4.8)	15000 (1034)
1/4	1/4	SS-HPHN-RT4	1.47 (37.4)	0.56 (14.3)	0.56 (14.2)	0.56 (14.2)	0.25 (6.4)	15000 (1034)
3/8	1/8	SS-HPHN-RT6-RT2	1.34 (34.1)	0.69 (17.5)	0.56 (14.2)	0.38 (9.7)	0.19 (4.8)	15000 (1034)
3/8	1/4	SS-HPHN-RT6-RT4	1.52 (38.6)	0.69 (17.5)	0.56 (14.2)	0.56 (14.2)	0.25 (6.4)	15000 (1034)
3/8	3/8	SS-HPHN-RT6	1.52 (38.6)	0.69 (17.5)	0.56 (14.2)	0.56 (14.2)	0.31 (7.9)	15000 (1034)
1/2	1/8	SS-HPHN-RT8-RT2	1.58 (40.2)	0.87 (22.2)	0.75 (19.1)	0.38 (9.7)	0.19 (4.8)	15000 (1034)
1/2	1/4	SS-HPHN-RT8-RT4	1.76 (44.7)	0.87 (22.2)	0.75 (19.1)	0.56 (14.2)	0.25 (6.4)	15000 (1034)
1/2	3/8	SS-HPHN-RT8-RT6	1.76 (44.7)	0.87 (22.2)	0.75 (19.1)	0.56 (14.2)	0.31 (7.9)	15000 (1034)
1/2	1/2	SS-HPHN-RT8	1.95 (49.6)	0.87 (22.2)	0.75 (19.1)	0.75 (19.1)	0.38 (9.6)	15000 (1034)
3/4	1/8	SS-HPHN-RT12-RT2	1.67 (42.4)	1.06 (27.0)	0.75 (19.1)	0.38 (9.7)	0.22 (5.5)	10000 (690)
3/4	1/4	SS-HPHN-RT12-RT4	1.85 (46.9)	1.06 (27.0)	0.75 (19.1)	0.56 (14.2)	0.28 (7.1)	10000 (690)
3/4	3/8	SS-HPHN-RT12-RT6	1.85 (46.9)	1.06 (27.0)	0.75 (19.1)	0.56 (14.2)	0.38 (9.6)	10000 (690)
3/4	1/2	SS-HPHN-RT12-RT8	2.04 (51.8)	1.06 (27.0)	0.75 (19.1)	0.75 (19.1)	0.47 (11.9)	10000 (690)
3/4	3/4	SS-HPHN-RT12	2.04 (51.8)	1.06 (27.0)	0.75 (19.1)	0.75 (19.1)	0.58 (14.8)	10000 (690)
1	1/8	SS-HPHN-RT16-RT2	1.96 (49.8)	1.37 (34.9)	0.94 (23.9)	0.38 (9.7)	0.22 (5.5)	10000 (690)
1	1/4	SS-HPHN-RT16-RT4	2.14 (54.3)	1.37 (34.9)	0.94 (23.9)	0.56 (14.2)	0.28 (7.1)	10000 (690)
1	3/8	SS-HPHN-RT16-RT6	2.14 (54.3)	1.37 (34.9)	0.94 (23.9)	0.56 (14.2)	0.38 (9.6)	10000 (690)
1	1/2	SS-HPHN-RT16-RT8	2.33 (59.2)	1.37 (34.9)	0.94 (23.9)	0.75 (19.1)	0.47 (11.9)	10000 (690)
1	3/4	SS-HPHN-RT16-RT12	2.33 (59.2)	1.37 (34.9)	0.94 (23.9)	0.75 (19.1)	0.58 (14.8)	10000 (690)
1	1	SS-HPHN-RT16	2.52 (64.0)	1.37 (34.9)	0.94 (23.9)	0.94 (23.9)	0.79 (20.0)	10000 (690)

Hex Nipples

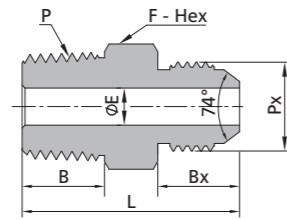

Male NPT Threads			Dimension, in. (mm)					Male JIC
P-NPT Size	Px-SAE/MS Thread Size	Ordering Number	L	F	B	Bx	E	Working Pressure psig (bar)
1/8	7/16-20	SS-HPHN-NS2-AN4	1.23 (31.3)	0.50 (12.7)	0.38 (9.7)	0.55 (14.0)	0.17 (4.4)	15000 (1034)
1/8	9/16-18	SS-HPHN-NS2-AN6	1.31 (33.4)	0.63 (15.9)	0.38 (9.7)	0.56 (14.1)	0.19 (4.8)	15000 (1034)
1/4	7/16-20	SS-HPHN-NS4-AN4	1.46 (37.2)	0.56 (14.3)	0.56 (14.2)	0.55 (14.0)	0.17 (4.4)	15000 (1034)
1/4	9/16-18	SS-HPHN-NS4-AN6	1.49 (37.9)	0.63 (15.9)	0.56 (14.2)	0.56 (14.1)	0.23 (5.8)	15000 (1034)
1/4	3/4-16	SS-HPHN-NS4-AN8	1.65 (41.9)	0.81 (20.6)	0.56 (14.2)	0.66 (16.7)	0.25 (6.4)	15000 (1034)
3/8	7/16-20	SS-HPHN-NS6-AN4	1.52 (38.5)	0.69 (17.5)	0.56 (14.2)	0.55 (14.0)	0.17 (4.4)	15000 (1034)
3/8	9/16-18	SS-HPHN-NS6-AN6	1.52 (38.5)	0.69 (17.5)	0.56 (14.2)	0.56 (14.1)	0.23 (5.8)	15000 (1034)
3/8	3/4-16	SS-HPHN-NS6-AN8	1.62 (41.1)	0.81 (20.6)	0.56 (14.2)	0.66 (16.7)	0.31 (7.9)	15000 (1034)
1/2	7/16-20	SS-HPHN-NS8-AN4	1.75 (44.5)	0.87 (22.2)	0.75 (19.1)	0.55 (14.0)	0.17 (4.4)	15000 (1034)
1/2	9/16-18	SS-HPHN-NS8-AN6	1.75 (44.6)	0.87 (22.2)	0.75 (19.1)	0.56 (14.1)	0.23 (5.8)	15000 (1034)
1/2	3/4-16	SS-HPHN-NS8-AN8	1.86 (47.2)	0.87 (22.2)	0.75 (19.1)	0.66 (16.7)	0.31 (8.0)	15000 (1034)
1/2	7/8-14	SS-HPHN-NS8-AN10	1.98 (50.4)	0.94 (23.8)	0.75 (19.1)	0.76 (19.3)	0.37 (9.4)	15000 (1034)
3/4	3/4-16	SS-HPHN-NS12-AN8	1.94 (49.4)	1.06 (27.0)	0.75 (19.1)	0.66 (16.7)	0.39 (9.9)	10000 (690)
3/4	7/8-14	SS-HPHN-NS12-AN10	2.05 (52.0)	1.06 (27.0)	0.75 (19.1)	0.76 (19.3)	0.48 (12.3)	10000 (690)
3/4	1 1/16-12	SS-HPHN-NS12-AN12	2.17 (55.0)	1.13 (28.6)	0.75 (19.1)	0.86 (21.9)	0.58 (14.8)	10000 (690)
3/4	1 5/16-12	SS-HPHN-NS12-AN16	2.30 (58.4)	1.37 (34.9)	0.75 (19.1)	0.91 (23.1)	0.57 (14.6)	10000 (690)
1	1 1/16-12	SS-HPHN-NS16-AN12	2.44 (62.0)	1.37 (34.9)	0.94 (23.9)	0.86 (21.9)	0.61 (15.5)	10000 (690)
1	1 5/16-12	SS-HPHN-NS16-AN16	2.49 (63.2)	1.37 (34.9)	0.94 (23.9)	0.91 (23.1)	0.79 (20.0)	10000 (690)

Hex Nipples

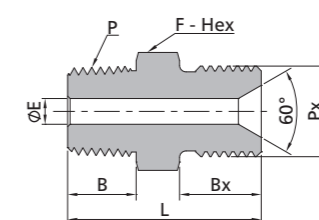

Male NPT Threads			Dimension, in. (mm)					Type "M" Male
P-NPT Size	Px-SAE/MS Thread Size	Ordering Number	L	F	B	Bx	E	Working Pressure psig (bar)
1/8	9/16-18	SS-HPHN-NS2-HM9	1.22 (31.0)	0.63 (15.9)	0.38 (9.7)	0.50 (12.7)	0.09 (2.4)	15000 (1034)
1/8	3/4-16	SS-HPHN-NS2-HM12	13.9 (35.3)	0.75 (19.1)	0.38 (9.7)	0.63 (16.0)	0.19 (4.8)	15000 (1034)
1/4	9/16-18	SS-HPHN-NS4-HM9	1.40 (35.5)	0.63 (15.9)	0.56 (14.2)	0.50 (12.7)	0.09 (2.4)	15000 (1034)
1/4	3/4-16	SS-HPHN-NS4-HM12	1.57 (39.8)	0.75 (19.1)	0.56 (14.2)	0.63 (16.0)	0.25 (6.4)	15000 (1034)
1/4	7/8-14	SS-HPHN-NS4-HM14	1.77 (45.0)	1.00 (25.4)	0.56 (14.2)	0.76 (19.2)	0.15 (3.8)	15000 (1034)
3/8	9/16-18	SS-HPHN-NS6-HM9	1.42 (36.1)	0.69 (17.5)	0.56 (14.2)	0.50 (12.7)	0.09 (2.4)	15000 (1034)
3/8	3/4-16	SS-HPHN-NS6-HM12	1.57 (39.8)	0.75 (19.1)	0.56 (14.2)	0.63 (16.0)	0.29 (7.4)	15000 (1034)
3/8	7/8-14	SS-HPHN-NS6-HM14	1.96 (49.9)	1.00 (25.4)	0.56 (14.2)	0.76 (19.2)	0.15 (3.8)	15000 (1034)
1/2	9/16-18	SS-HPHN-NS8-HM9	1.66 (42.2)	0.87 (22.2)	0.75 (19.1)	0.50 (12.7)	0.09 (2.4)	15000 (1034)
1/2	3/4-16	SS-HPHN-NS8-HM12	1.79 (45.5)	0.87 (22.2)	0.75 (19.1)	0.63 (16.0)	0.29 (7.4)	15000 (1034)
1/2	7/8-14	SS-HPHN-NS8-HM14	1.96 (49.9)	1.00 (25.4)	0.75 (19.1)	0.76 (19.2)	0.15 (3.8)	15000 (1034)
1/2	1-12	SS-HPHN-NS8-HM16	1.85 (47.0)	1.00 (25.4)	0.75 (19.1)	0.64 (16.3)	0.38 (9.6)	15000 (1034)
3/4	9/16-18	SS-HPHN-NS12-HM9	1.75 (44.4)	1.06 (27.0)	0.75 (19.1)	0.50 (12.7)	0.09 (2.4)	10000 (690)
3/4	3/4-16	SS-HPHN-NS12-HM12	1.88 (47.7)	1.06 (27.0)	0.75 (19.1)	0.63 (16.0)	0.29 (7.4)	10000 (690)
3/4	7/8-14	SS-HPHN-NS12-HM14	2.00 (50.9)	1.06 (27.0)	0.75 (19.1)	0.76 (19.2)	0.15 (3.8)	10000 (690)
3/4	1-12	SS-HPHN-NS12-HM16	1.89 (48.0)	1.06 (27.0)	0.75 (19.1)	0.64 (16.3)	0.39 (10.0)	10000 (690)
1	1-12	SS-HPHN-NS16-HM16	2.18 (55.4)	1.37 (34.9)	0.94 (23.9)	0.64 (16.3)	0.39 (10.0)	10000 (690)
1	1 5/16-12	SS-HPHN-NS16-HM21	2.16 (54.8)	1.37 (34.9)	0.94 (23.9)	0.62 (15.7)	0.69 (17.5)	10000 (690)

Hex Nipples

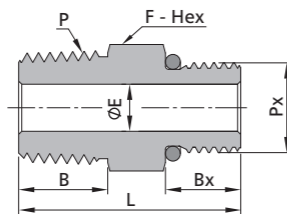

Male NPT Threads			Male SAE/MS Straight Threads					Working Pressure psig (bar)
P-NPT Size	Px-SAE/MS Thread Size	Ordering Number	L	F	B	Bx	E	Working Pressure psig (bar)
1/4	7/16-20	SS-HPHN-NS4-SH7	1.35 (34.2)	0.56 (14.3)	0.56 (14.2)	0.43 (11.0)	0.18 (4.5)	10000 (690)
1/4	9/16-18	SS-HPHN-NS4-SH9	1.43 (36.4)	0.69 (17.5)	0.56 (14.2)	0.47 (12.0)	0.28 (7.1)	10000 (690)
3/8	7/16-20	SS-HPHN-NS6-SH7	1.39 (35.4)	0.69 (17.5)	0.56 (14.2)	0.43 (11.0)	0.18 (4.5)	10000 (690)
3/8	9/16-18	SS-HPHN-NS6-SH9	1.43 (36.4)	0.69 (17.5)	0.56 (14.2)	0.47 (12.0)	0.30 (7.5)	10000 (690)
3/8	3/4-16	SS-HPHN-NS6-SH12	1.56 (39.6)	0.87 (22.2)	0.56 (14.2)	0.55 (14.0)	0.38 (9.6)	10000 (690)
1/2	9/16-18	SS-HPHN-NS8-SH9	1.67 (42.5)	0.87 (22.2)	0.75 (19.1)	0.47 (12.0)	0.30 (7.5)	10000 (690)
1/2	3/4-16	SS-HPHN-NS8-SH12	1.75 (44.5)	0.87 (22.2)	0.75 (19.1)	0.55 (14.0)	0.39 (10.0)	10000 (690)
1/2	7/8-14	SS-HPHN-NS8-SH14	1.88 (47.7)	1.00 (25.4)	0.75 (19.1)	0.63 (16.0)	0.47 (11.9)	10000 (690)
3/4	9/16-18	SS-HPHN-NS12-SH9	1.76 (44.7)	1.06 (27.0)	0.75 (19.1)	0.47 (12.0)	0.30 (7.5)	10000 (690)
3/4	3/4-16	SS-HPHN-NS12-SH12	1.84 (46.7)	1.06 (27.0)	0.75 (19.1)	0.55 (14.0)	0.39 (10.0)	10000 (690)
3/4	7/8-14	SS-HPHN-NS12-SH14	1.92 (48.7)	1.06 (27.0)	0.75 (19.1)	0.63 (16.0)	0.49 (12.5)	10000 (690)
1	3/4-16	SS-HPHN-NS16-SH12	2.13 (54.1)	1.37 (34.9)	0.94 (23.9)	0.55 (14.0)	0.39 (10.0)	10000 (690)
1	7/8-14	SS-HPHN-NS16-SH14	2.21 (56.1)	1.37 (34.9)	0.94 (23.9)	0.63 (16.0)	0.49 (12.5)	10000 (690)

Hex Nipples

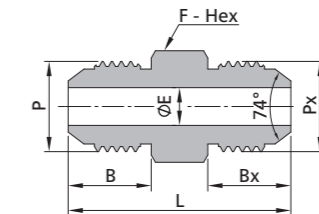

Male JIC			Dimension, in. (mm)					Working Pressure psig (bar)
P-SAE/MS Thread Size	Px-SAE/MS Thread Size	Ordering Number	L	F	B	Bx	E	Working Pressure psig (bar)
7/16-20	7/16-20	SS-HPHN-AN4	1.40 (35.6)	0.50 (12.7)	0.55 (14.0)	0.55 (14.0)	0.17 (4.4)	20000 (1379)
9/16-18	7/16-20	SS-HPHN-AN6-AN4	1.48 (37.7)	0.63 (15.9)	0.56 (14.1)	0.55 (14.0)	0.17 (4.4)	20000 (1379)
9/16-18	9/16-18	SS-HPHN-AN6	1.49 (37.8)	0.63 (15.9)	0.56 (14.1)	0.56 (14.1)	0.23 (5.8)	20000 (1379)
3/4-16	9/16-18	SS-HPHN-AN8-AN6	1.65 (41.8)	0.81 (20.6)	0.66 (16.7)	0.56 (14.1)	0.23 (5.8)	20000 (1379)
3/4-16	3/4-16	SS-HPHN-AN8	1.75 (44.4)	0.81 (20.6)	0.66 (16.7)	0.66 (16.7)	0.31 (8.0)	20000 (1379)
7/8-14	9/16-18	SS-HPHN-AN10-AN6	1.79 (45.4)	0.94 (23.8)	0.76 (19.3)	0.56 (14.1)	0.23 (5.8)	20000 (1379)
7/8-14	3/4-16	SS-HPHN-AN10-AN8	1.89 (48.0)	0.94 (23.8)	0.76 (19.3)	0.66 (16.7)	0.31 (8.0)	20000 (1379)
7/8-14	7/8-14	SS-HPHN-AN10	1.99 (50.6)	0.94 (23.8)	0.76 (19.3)	0.76 (19.3)	0.37 (9.4)	20000 (1379)
1 1/16-12	3/4-16	SS-HPHN-AN12-AN8	2.07 (52.6)	1.13 (28.6)	0.86 (21.9)	0.66 (16.7)	0.31 (8.0)	15000 (1034)
1 1/16-12	7/8-14	SS-HPHN-AN12-AN10	2.17 (55.2)	1.13 (28.6)	0.86 (21.9)	0.76 (19.3)	0.37 (9.4)	15000 (1034)
1 1/16-12	1 1/16-12	SS-HPHN-AN12	2.28 (57.8)	1.13 (28.6)	0.86 (21.9)	0.86 (21.9)	0.46 (11.6)	15000 (1034)
1 5/16-12	7/8-14	SS-HPHN-AN16-AN10	2.31 (58.6)	1.37 (34.9)	0.91 (23.1)	0.76 (19.3)	0.37 (9.4)	15000 (1034)
1 5/16-12	1 1/16-12	SS-HPHN-AN16-AN12	2.41 (61.2)	1.37 (34.9)	0.91 (23.1)	0.86 (21.9)	0.46 (11.6)	15000 (1034)
1 5/16-12	1 5/16-12	SS-HPHN-AN16	2.46 (62.4)	1.37 (34.9)	0.91 (23.1)	0.91 (23.1)	0.57 (14.6)	15000 (1034)

Hex Nipples

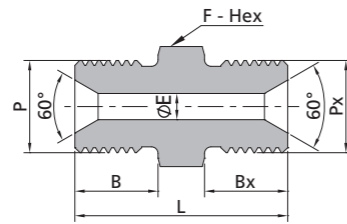

Type "M" Male			Dimension, in. (mm)					Type "M" Male
Px- SAE/MS Thread Size	Px- SAE/MS Thread Size	Ordering Number	L	F	B	Bx	E	Working Pressure psig (bar)
9/16-18	9/16-18	SS-HPHN-HM9	1.34 (34.0)	0.63 (15.9)	0.50 (12.7)	0.50 (12.7)	0.09 (2.4)	60000 (4137)
3/4-16	9/16-18	SS-HPHN-HM12-HM9	1.51 (38.3)	0.75 (19.1)	0.63 (16.0)	0.50 (12.7)	0.09 (2.4)	30000 (2068)
3/4-16	3/4-16	SS-HPHN-HM12	1.64 (41.6)	0.75 (19.1)	0.63 (16.0)	0.63 (16.0)	0.29 (7.4)	30000 (2068)
7/8-14	9/16-18	SS-HPHN-HM14-HM9	1.71 (43.5)	1.00 (25.4)	0.76 (19.2)	0.50 (12.7)	0.09 (2.4)	50000 (3447)
7/8-14	3/4-16	SS-HPHN-HM14-HM12	1.84 (46.8)	1.00 (25.4)	0.76 (19.2)	0.63 (16.0)	0.15 (3.8)	30000 (2068)
7/8-14	7/8-14	SS-HPHN-HM14	1.97 (50.0)	1.00 (25.4)	0.76 (19.2)	0.76 (19.2)	0.15 (3.8)	50000 (3447)
1-12	9/16-18	SS-HPHN-HM16-HM9	1.60 (40.6)	1.00 (25.4)	0.64 (16.3)	0.50 (12.7)	0.09 (2.4)	30000 (2068)
1-12	3/4-16	SS-HPHN-HM16-HM12	1.73 (43.9)	1.00 (25.4)	0.64 (16.3)	0.63 (16.0)	0.29 (7.4)	30000 (2068)
1-12	7/8-14	SS-HPHN-HM16-HM14	1.85 (47.1)	1.00 (25.4)	0.64 (16.3)	0.76 (19.2)	0.15 (3.8)	30000 (2068)
1-12	1-12	SS-HPHN-HM16	1.74 (44.2)	1.00 (25.4)	0.64 (16.3)	0.64 (16.3)	0.39 (10.0)	30000 (2068)
1 5/16-12	1-12	SS-HPHN-HM21-HM16	1.86 (47.2)	1.37 (34.9)	0.62 (15.7)	0.64 (16.3)	0.39 (10.0)	20000 (1379)
1 5/16-12	1 5/16-12	SS-HPHN-HM21	1.83 (46.6)	1.37 (34.9)	0.62 (15.7)	0.62 (15.7)	0.69 (17.5)	20000 (1379)

Hex Long Nipples

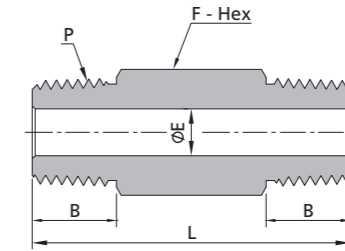

Male NPT Threads		Dimension, in. (mm)				Working Pressure psig (bar)
P-NPT Size	Ordering Number	L	F	B	E	
1/8	SS-HPLN-NS2-1.5	1.50 (38.1)	0.44 (11.1)	0.38 (9.7)	0.19 (4.8)	15000 (1034)
1/8	SS-HPLN-NS2-2	2.00 (50.8)	0.44 (11.1)	0.38 (9.7)	0.19 (4.8)	15000 (1034)
1/8	SS-HPLN-NS2-2.5	2.50 (63.5)	0.44 (11.1)	0.38 (9.7)	0.19 (4.8)	15000 (1034)
1/8	SS-HPLN-NS2-3	3.00 (76.2)	0.44 (11.1)	0.38 (9.7)	0.19 (4.8)	15000 (1034)
1/4	SS-HPLN-NS4-2	2.00 (50.8)	0.56 (14.3)	0.56 (14.2)	0.25 (6.4)	15000 (1034)
1/4	SS-HPLN-NS4-2.5	2.50 (63.5)	0.56 (14.3)	0.56 (14.2)	0.25 (6.4)	15000 (1034)
1/4	SS-HPLN-NS4-3	3.00 (76.2)	0.56 (14.3)	0.56 (14.2)	0.25 (6.4)	15000 (1034)
1/4	SS-HPLN-NS4-4	4.00 (101.6)	0.56 (14.3)	0.56 (14.2)	0.25 (6.4)	15000 (1034)
3/8	SS-HPLN-NS6-2	2.00 (50.8)	0.69 (17.5)	0.56 (14.2)	0.31 (7.9)	15000 (1034)
3/8	SS-HPLN-NS6-2.5	2.50 (63.5)	0.69 (17.5)	0.56 (14.2)	0.31 (7.9)	15000 (1034)
3/8	SS-HPLN-NS6-3	3.00 (76.2)	0.69 (17.5)	0.56 (14.2)	0.31 (7.9)	15000 (1034)
3/8	SS-HPLN-NS6-4	4.00 (101.6)	0.69 (17.5)	0.56 (14.2)	0.31 (7.9)	15000 (1034)
1/2	SS-HPLN-NS8-3	3.00 (76.2)	0.87 (22.2)	0.75 (19.1)	0.38 (9.6)	15000 (1034)
1/2	SS-HPLN-NS8-4	4.00 (101.6)	0.87 (22.2)	0.75 (19.1)	0.38 (9.6)	15000 (1034)
1/2	SS-HPLN-NS8-6	6.00 (152.4)	0.87 (22.2)	0.75 (19.1)	0.38 (9.6)	15000 (1034)
3/4	SS-HPLN-NS12-3	3.00 (76.2)	1.06 (27.0)	0.75 (19.1)	0.58 (14.8)	10000 (690)
3/4	SS-HPLN-NS12-4	4.00 (101.6)	1.06 (27.0)	0.75 (19.1)	0.58 (14.8)	10000 (690)
1	SS-HPLN-NS16-3	3.00 (76.2)	1.37 (34.9)	0.94 (23.9)	0.79 (20.0)	10000 (690)
1	SS-HPLN-NS16-4	4.00 (101.6)	1.37 (34.9)	0.94 (23.9)	0.79 (20.0)	10000 (690)

Hex Long Nipples

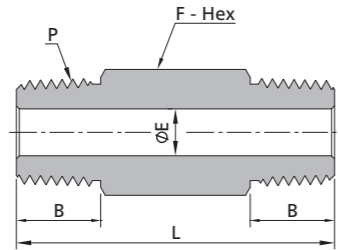

Male ISO Tapered Threads						
P-ISO Tapered Size	Ordering Number	Dimension, in. (mm)				Working Pressure psig (bar)
		L	F	B	E	
1/8	SS-HPLN-RT2-1.5	1.50 (38.1)	0.44 (11.1)	0.38 (9.7)	0.19 (4.8)	15000 (1034)
1/8	SS-HPLN-RT2-2	2.00 (50.8)	0.44 (11.1)	0.38 (9.7)	0.19 (4.8)	15000 (1034)
1/8	SS-HPLN-RT2-2.5	2.50 (63.5)	0.44 (11.1)	0.38 (9.7)	0.19 (4.8)	15000 (1034)
1/8	SS-HPLN-RT2-3	3.00 (76.2)	0.44 (11.1)	0.38 (9.7)	0.19 (4.8)	15000 (1034)
1/4	SS-HPLN-RT4-2	2.00 (50.8)	0.56 (14.3)	0.56 (14.2)	0.25 (6.4)	15000 (1034)
1/4	SS-HPLN-RT4-2.5	2.50 (63.5)	0.56 (14.3)	0.56 (14.2)	0.25 (6.4)	15000 (1034)
1/4	SS-HPLN-RT4-3	3.00 (76.2)	0.56 (14.3)	0.56 (14.2)	0.25 (6.4)	15000 (1034)
1/4	SS-HPLN-RT4-4	4.00 (101.6)	0.56 (14.3)	0.56 (14.2)	0.25 (6.4)	15000 (1034)
3/8	SS-HPLN-RT6-2	2.00 (50.8)	0.69 (17.5)	0.56 (14.2)	0.31 (7.9)	15000 (1034)
3/8	SS-HPLN-RT6-2.5	2.50 (63.5)	0.69 (17.5)	0.56 (14.2)	0.31 (7.9)	15000 (1034)
3/8	SS-HPLN-RT6-3	3.00 (76.2)	0.69 (17.5)	0.56 (14.2)	0.31 (7.9)	15000 (1034)
3/8	SS-HPLN-RT6-4	4.00 (101.6)	0.69 (17.5)	0.56 (14.2)	0.31 (7.9)	15000 (1034)
1/2	SS-HPLN-RT8-3	3.00 (76.2)	0.87 (22.2)	0.75 (19.1)	0.38 (9.6)	15000 (1034)
1/2	SS-HPLN-RT8-4	4.00 (101.6)	0.87 (22.2)	0.75 (19.1)	0.38 (9.6)	15000 (1034)
1/2	SS-HPLN-RT8-6	6.00 (152.4)	0.87 (22.2)	0.75 (19.1)	0.38 (9.6)	15000 (1034)
3/4	SS-HPLN-RT12-3	3.00 (76.2)	1.06 (27.0)	0.75 (19.1)	0.58 (14.8)	10000 (690)
3/4	SS-HPLN-RT12-4	4.00 (101.6)	1.06 (27.0)	0.75 (19.1)	0.58 (14.8)	10000 (690)
1	SS-HPLN-RT16-3	3.00 (76.2)	1.37 (34.9)	0.94 (23.9)	0.79 (20.0)	10000 (690)
1	SS-HPLN-RT16-4	4.00 (101.6)	1.37 (34.9)	0.94 (23.9)	0.79 (20.0)	10000 (690)

Pipe Caps

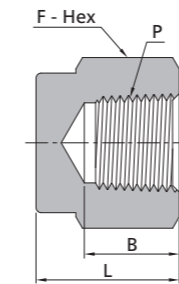

Female ISO Tapered Threads					
P-ISO Tapered Size	Ordering Number	Dimension, in. (mm)			Working Pressure psig (bar)
		L	F	B	
1/8	SS-HPC-RT2	0.75 (19.1)	0.63 (15.9)	0.41 (10.4)	15000 (1034)
1/4	SS-HPC-RT4	0.91 (23.1)	0.94 (23.8)	0.59 (15.0)	15000 (1034)
3/8	SS-HPC-RT6	1.03 (26.2)	1.13 (28.6)	0.59 (15.0)	15000 (1034)
1/2	SS-HPC-RT8	1.34 (34.0)	1.37 (34.9)	0.78 (19.8)	15000 (1034)
3/4	SS-HPC-RT12	1.62 (36.6)	1.50 (38.1)	0.81 (20.6)	10000 (690)
1	SS-HPC-RT16	1.62 (41.1)	1.75 (44.5)	1.00 (25.4)	10000 (690)

Pipe Caps

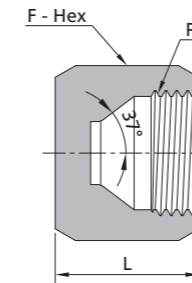

Female JIC				
P-SAE/MS Thread Size	Ordering Number	Dimension, in. (mm)		Working Pressure psig (bar)
		L	F	
7/16-20	SS-HPC-AN4	0.63 (16.1)	0.56 (14.3)	20000 (1379)
9/16-18	SS-HPC-AN6	0.72 (18.3)	0.69 (17.5)	20000 (1379)
3/4-16	SS-HPC-AN8	0.85 (21.6)	0.87 (22.2)	20000 (1379)
7/8-14	SS-HPC-AN10	0.98 (24.9)	1.00 (25.4)	20000 (1379)
1 1/16-12	SS-HPC-AN12	1.06 (26.8)	1.25 (31.8)	15000 (1034)
1 5/16-12	SS-HPC-AN16	1.18 (30.0)	1.50 (38.1)	15000 (1034)

Pipe Caps

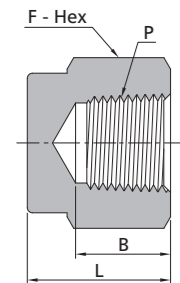

Female NPT Threads					
P-NPT Size	Ordering Number	Dimension, in. (mm)			Working Pressure psig (bar)
		L	F	B	
1/8	SS-HPC-NS2	0.75 (19.1)	0.63 (15.9)	0.41 (10.4)	15000 (1034)
1/4	SS-HPC-NS4	0.91 (23.1)	0.94 (23.8)	0.59 (15.0)	15000 (1034)
3/8	SS-HPC-NS6	1.03 (26.2)	1.13 (28.6)	0.59 (15.0)	15000 (1034)
1/2	SS-HPC-NS8	1.34 (34.0)	1.37 (34.9)	0.78 (19.8)	15000 (1034)
3/4	SS-HPC-NS12	1.62 (36.6)	1.50 (38.1)	0.81 (20.6)	10000 (690)
1	SS-HPC-NS16	1.62 (41.1)	1.75 (44.5)	1.00 (25.4)	10000 (690)

Pipe Caps Assembly(Moveable Insert)

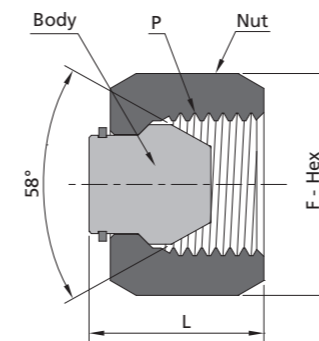

Moveable insert Type "M" Female				
P-SAE/MS Thread Size	Ordering Number	Dimension, in. (mm)		Working Pressure psig (bar)
		L	F	
9/16-18	SS-HMC-HM9	0.85 (21.6)	0.69 (17.5)	60000 (4137)
3/4-16	SS-HMC-HM12	0.91 (23.1)	1.00 (25.4)	30000 (2068)
7/8-14	SS-HMC-HM14	1.28 (32.5)	1.19 (30.2)	50000 (3447)
1-12	SS-HMC-HM16	1.25 (31.8)	1.25 (31.8)	30000 (2068)
1 5/16-12	SS-HMC-HM21	1.18 (30.0)	1.50 (38.1)	20000 (1379)

Hex Couplings

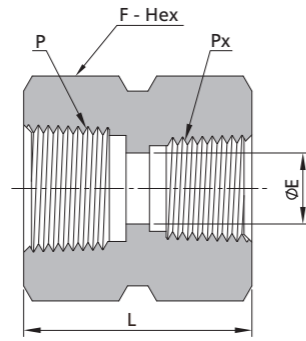

Female NPT Threads						
P-NPT Size	Px-NPT Size	Ordering Number	Dimension, in. (mm)			Working Pressure psig (bar)
			L	F	E	
1/8	1/8	SS-HPCG-NS2	0.94 (23.8)	0.63 (15.9)	0.31 (8.0)	15000 (1034)
1/4	1/8	SS-HPCG-NS4-NS2	1.14 (28.9)	0.94 (23.8)	0.31 (8.0)	15000 (1034)
1/4	1/4	SS-HPCG-NS4	1.32 (33.5)	0.94 (23.8)	0.41 (10.4)	15000 (1034)
3/8	1/8	SS-HPCG-NS6-NS2	1.14 (28.9)	1.13 (28.6)	0.31 (8.0)	15000 (1034)
3/8	1/4	SS-HPCG-NS6-NS4	1.32 (33.5)	1.13 (28.6)	0.41 (10.4)	15000 (1034)
3/8	3/8	SS-HPCG-NS6	1.32 (33.5)	1.13 (28.6)	0.54 (13.8)	15000 (1034)
1/2	1/8	SS-HPCG-NS8-NS2	1.35 (34.2)	1.37 (34.9)	0.31 (8.0)	15000 (1034)
1/2	1/4	SS-HPCG-NS8-NS4	1.53 (38.8)	1.37 (34.9)	0.41 (10.4)	15000 (1034)
1/2	3/8	SS-HPCG-NS8-NS6	1.53 (38.8)	1.37 (34.9)	0.54 (13.8)	15000 (1034)
1/2	1/2	SS-HPCG-NS8	1.72 (43.8)	1.37 (34.9)	0.67 (17.0)	15000 (1034)
3/4	1/8	SS-HPCG-NS12-NS2	1.40 (35.5)	1.50 (38.1)	0.31 (8.0)	10000 (690)
3/4	1/4	SS-HPCG-NS12-NS4	1.58 (40.1)	1.50 (38.1)	0.41 (10.4)	10000 (690)
3/4	3/8	SS-HPCG-NS12-NS6	1.58 (40.1)	1.50 (38.1)	0.54 (13.8)	10000 (690)
3/4	1/2	SS-HPCG-NS12-NS8	1.79 (45.4)	1.50 (38.1)	0.67 (17.0)	10000 (690)
3/4	3/4	SS-HPCG-NS12	1.84 (46.7)	1.50 (38.1)	0.88 (22.3)	10000 (690)
1	1/8	SS-HPCG-NS16-NS2	1.59 (40.5)	1.75 (44.5)	0.31 (8.0)	10000 (690)
1	1/4	SS-HPCG-NS16-NS4	1.76 (44.8)	1.75 (44.5)	0.41 (10.4)	10000 (690)
1	3/8	SS-HPCG-NS16-NS6	1.76 (44.8)	1.75 (44.5)	0.54 (13.8)	10000 (690)
1	1/2	SS-HPCG-NS16-NS8	1.96 (49.7)	1.75 (44.5)	0.67 (17.0)	10000 (690)
1	3/4	SS-HPCG-NS16-NS12	2.00 (50.7)	1.75 (44.5)	0.88 (22.3)	10000 (690)
1	1	SS-HPCG-NS16	2.19 (55.5)	1.75 (44.5)	1.11 (28.1)	10000 (690)

Hex Couplings

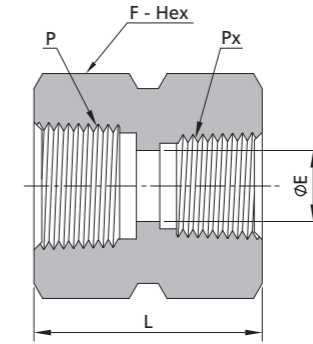

Female NPT Threads			Female ISO Tapered Threads			
P-NPT Size	Px-ISO Tapered Size	Ordering Number	Dimension, in. (mm)			Working Pressure psig (bar)
			L	F	E	
1/8	1/8	SS-HPCG-NS2-RT2	0.94 (23.8)	0.63 (15.9)	0.31 (8.0)	15000 (1034)
1/4	1/8	SS-HPCG-NS4-RT2	1.14 (28.9)	0.94 (23.8)	0.31 (8.0)	15000 (1034)
1/4	1/4	SS-HPCG-NS4-RT4	1.32 (33.5)	0.94 (23.8)	0.41 (10.4)	15000 (1034)
3/8	1/8	SS-HPCG-NS6-RT2	1.14 (28.9)	1.13 (28.6)	0.31 (8.0)	15000 (1034)
3/8	1/4	SS-HPCG-NS6-RT4	1.32 (33.5)	1.13 (28.6)	0.41 (10.4)	15000 (1034)
3/8	3/8	SS-HPCG-NS6-RT6	1.32 (33.5)	1.13 (28.6)	0.54 (13.8)	15000 (1034)
1/2	1/8	SS-HPCG-NS8-RT2	1.35 (34.2)	1.37 (34.9)	0.31 (8.0)	15000 (1034)
1/2	1/4	SS-HPCG-NS8-RT4	1.53 (38.8)	1.37 (34.9)	0.41 (10.4)	15000 (1034)
1/2	3/8	SS-HPCG-NS8-RT6	1.53 (38.8)	1.37 (34.9)	0.54 (13.8)	15000 (1034)
1/2	1/2	SS-HPCG-NS8-RT8	1.72 (43.8)	1.37 (34.9)	0.67 (17.0)	15000 (1034)
3/4	1/8	SS-HPCG-NS12-RT2	1.40 (35.5)	1.50 (38.1)	0.31 (8.0)	10000 (690)
3/4	1/4	SS-HPCG-NS12-RT4	1.58 (40.1)	1.50 (38.1)	0.41 (10.4)	10000 (690)
3/4	3/8	SS-HPCG-NS12-RT6	1.58 (40.1)	1.50 (38.1)	0.54 (13.8)	10000 (690)
3/4	1/2	SS-HPCG-NS12-RT8	1.79 (45.4)	1.50 (38.1)	0.69 (17.4)	10000 (690)
3/4	3/4	SS-HPCG-NS12-RT12	1.84 (46.7)	1.50 (38.1)	0.88 (22.3)	10000 (690)
1	1/8	SS-HPCG-NS16-RT2	1.59 (40.5)	1.75 (44.5)	0.31 (8.0)	10000 (690)
1	1/4	SS-HPCG-NS16-RT4	1.76 (44.8)	1.75 (44.5)	0.41 (10.4)	10000 (690)
1	3/8	SS-HPCG-NS16-RT6	1.76 (44.8)	1.75 (44.5)	0.54 (13.8)	10000 (690)
1	1/2	SS-HPCG-NS16-RT8	1.96 (49.7)	1.75 (44.5)	0.69 (17.4)	10000 (690)
1	3/4	SS-HPCG-NS16-RT12	2.00 (50.7)	1.75 (44.5)	0.90 (22.8)	10000 (690)
1	1	SS-HPCG-NS16-RT16	2.19 (55.5)	1.75 (44.5)	1.11 (28.1)	10000 (690)

Hex Couplings

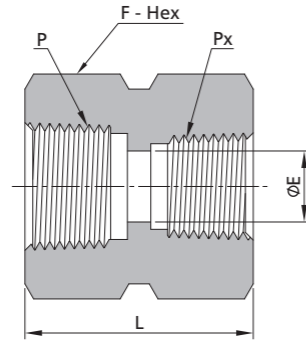

Female ISO Tapered Threads						
P-ISO Tapered Size	Px-ISO Tapered Size	Ordering Number	Dimension, in. (mm)			Working Pressure psig (bar)
			L	F	E	
1/8	1/8	SS-HPCG-RT2	0.94 (23.8)	0.63 (15.9)	0.31 (8.0)	15000 (1034)
1/4	1/8	SS-HPCG-RT4-RT2	1.14 (28.9)	0.94 (23.8)	0.31 (8.0)	15000 (1034)
1/4	1/4	SS-HPCG-RT4	1.32 (33.5)	0.94 (23.8)	0.41 (10.4)	15000 (1034)
3/8	1/8	SS-HPCG-RT6-RT2	1.14 (28.9)	1.13 (28.6)	0.31 (8.0)	15000 (1034)
3/8	1/4	SS-HPCG-RT6-RT4	1.32 (33.5)	1.13 (28.6)	0.41 (10.4)	15000 (1034)
3/8	3/8	SS-HPCG-RT6	1.32 (33.5)	1.13 (28.6)	0.54 (13.8)	15000 (1034)
1/2	1/8	SS-HPCG-RT8-RT2	1.35 (34.2)	1.37 (34.9)	0.31 (8.0)	15000 (1034)
1/2	1/4	SS-HPCG-RT8-RT4	1.53 (38.8)	1.37 (34.9)	0.41 (10.4)	15000 (1034)
1/2	3/8	SS-HPCG-RT8-RT6	1.53 (38.8)	1.37 (34.9)	0.54 (13.8)	15000 (1034)
1/2	1/2	SS-HPCG-RT8	1.72 (43.8)	1.37 (34.9)	0.69 (17.4)	10000 (690)
3/4	1/8	SS-HPCG-RT12-RT2	1.40 (35.5)	1.50 (38.1)	0.31 (8.0)	10000 (690)
3/4	1/4	SS-HPCG-RT12-RT4	1.58 (40.1)	1.50 (38.1)	0.41 (10.4)	10000 (690)
3/4	3/8	SS-HPCG-RT12-RT6	1.58 (40.1)	1.50 (38.1)	0.54 (13.8)	10000 (690)
3/4	1/2	SS-HPCG-RT12-RT8	1.79 (45.4)	1.50 (38.1)	0.90 (22.8)	10000 (690)
3/4	3/4	SS-HPCG-RT12	1.84 (46.7)	1.50 (38.1)	1.13 (28.7)	10000 (690)
1	1/8	SS-HPCG-RT16-RT2	1.59 (40.5)	1.75 (44.5)	0.31 (8.0)	10000 (690)
1	1/4	SS-HPCG-RT16-RT4	1.76 (44.8)	1.75 (44.5)	0.41 (10.4)	10000 (690)
1	3/8	SS-HPCG-RT16-RT6	1.76 (44.8)	1.75 (44.5)	0.54 (13.8)	10000 (690)
1	1/2	SS-HPCG-RT16-RT8	1.96 (49.7)	1.75 (44.5)	0.69 (17.4)	10000 (690)
1	3/4	SS-HPCG-RT16-RT12	2.00 (50.7)	1.75 (44.5)	0.90 (22.8)	10000 (690)
1	1	SS-HPCG-RT16	2.19 (55.5)	1.75 (44.5)	1.13 (28.7)	10000 (690)

Hex Couplings

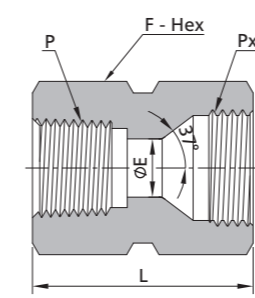

Female NPT Threads				Female JIC			
P-NPT Size	Px-SAE/MS Thread Size	Ordering Number	Dimension, in. (mm)			Working Pressure psig (bar)	
			L	F	E		
1/8	7/16-20	SS-HPCG-NS2-AN4	1.12 (28.4)	0.63 (15.9)	0.17 (4.3)	15000 (1034)	
1/4	7/16-20	SS-HPCG-NS4-AN4	1.33 (33.7)	0.94 (23.8)	0.17 (4.3)	15000 (1034)	
1/4	9/16-18	SS-HPCG-NS4-AN6	1.36 (34.5)	0.94 (23.8)	0.30 (7.5)	15000 (1034)	
3/8	7/16-20	SS-HPCG-NS6-AN4	1.33 (33.7)	1.13 (28.6)	0.17 (4.3)	15000 (1034)	
3/8	9/16-18	SS-HPCG-NS6-AN6	1.36 (34.5)	1.13 (28.6)	0.30 (7.5)	15000 (1034)	
3/8	3/4-16	SS-HPCG-NS6-AN8	1.44 (36.5)	1.13 (28.6)	0.39 (9.9)	15000 (1034)	
1/2	9/16-18	SS-HPCG-NS8-AN6	1.56 (39.7)	1.37 (34.9)	0.30 (7.5)	15000 (1034)	
1/2	3/4-16	SS-HPCG-NS8-AN8	1.64 (41.7)	1.37 (34.9)	0.39 (9.9)	15000 (1034)	
1/2	7/8-14	SS-HPCG-NS8-AN10	1.74 (44.1)	1.37 (34.9)	0.48 (12.3)	15000 (1034)	

Hex Couplings

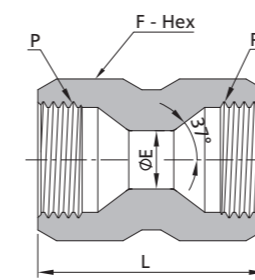

Female JIC						
P-SAE/MS Thread Size	Px-SAE/MS Thread Size	Ordering Number	Dimension, in. (mm)			Working Pressure psig (bar)
			L	F	E	
7/16-20	7/16-20	SS-HPCG-AN4	1.24 (31.5)	0.56 (14.3)	0.17 (4.3)	20000 (1379)
9/16-18	7/16-20	SS-HPCG-AN6-AN4	1.27 (32.3)	0.69 (17.5)	0.17 (4.3)	20000 (1379)
9/16-18	9/16-18	SS-HPCG-AN6	1.33 (33.8)	0.69 (17.5)	0.30 (7.5)	20000 (1379)
3/4-16	9/16-18	SS-HPCG-AN8-AN6	1.39 (35.4)	0.87 (22.2)	0.30 (7.5)	20000 (1379)
3/4-16	3/4-16	SS-HPCG-AN8	1.48 (37.6)	0.87 (22.2)	0.39 (9.9)	20000 (1379)
7/8-14	3/4-16	SS-HPCG-AN10-AN8	1.57 (40.0)	1.00 (25.4)	0.39 (9.9)	20000 (1379)
7/8-14	7/8-14	SS-HPCG-AN10	1.68 (42.6)	1.00 (25.4)	0.48 (12.3)	20000 (1379)
1 1/16-12	7/8-14	SS-HPCG-AN12-AN10	1.74 (44.1)	1.37 (34.8)	0.48 (12.3)	15000 (1034)
1 1/16-12	1 1/16-12	SS-HPCG-AN12	1.80 (45.8)	1.25 (31.8)	0.61 (15.5)	15000 (1034)
1 5/16-12	1 1/16-12	SS-HPCG-AN16-AN12	1.89 (48.1)	1.50 (38.1)	0.61 (15.5)	15000 (1034)
1 5/16-12	1 5/16-12	SS-HPCG-AN16	1.97 (50.1)	1.50 (38.1)	0.84 (21.4)	15000 (1034)

Zero-Clearance Unions

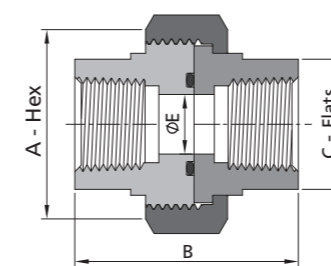

Female NPT Threads						
P-NPT Size	Ordering Number	Dimension, in. (mm)				Working Pressure psig (bar)
		A	B	C	E	
1/8	SS-HPZC-NS2	1.06 (27.0)	1.75 (44.5)	0.62 (15.8)	0.31 (8.0)	15000 (1034)
1/4	SS-HPZC-NS4	1.50 (38.1)	2.00 (50.8)	0.94 (23.8)	0.41 (10.4)	15000 (1034)
3/8	SS-HPZC-NS6	1.75 (44.5)	2.25 (57.2)	1.12 (28.5)	0.54 (13.8)	15000 (1034)
1/2	SS-HPZC-NS8	2.00 (50.8)	2.50 (63.5)	1.37 (34.9)	0.67 (17.0)	15000 (1034)
3/4	SS-HPZC-NS12	2.25 (57.2)	2.75 (69.9)	1.50 (38.1)	0.88 (22.3)	10000 (690)

Adapters

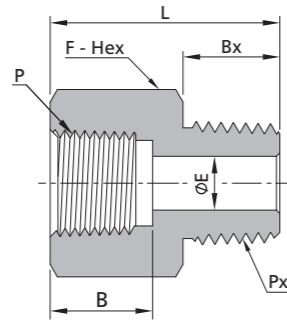

Female NPT Threads			Male NPT Threads					Working Pressure psig (bar)
P-NPT Size	Px-NPT Size	Ordering Number	Dimension, in. (mm)					
			L	F	B	Bx	E	
1/8	1/8	SS-HPA-NS2	0.96 (24.5)	0.63 (15.9)	0.41 (10.4)	0.38 (9.7)	0.19 (4.8)	15000 (1034)
1/8	1/4	SS-HPA-NS2-NS4	1.13 (28.8)	0.63 (15.9)	0.41 (10.4)	0.56 (14.2)	0.25 (6.4)	15000 (1034)
1/8	3/8	SS-HPA-NS2-NS6	1.14 (29.0)	0.69 (17.5)	0.41 (10.4)	0.56 (14.2)	0.31 (7.9)	15000 (1034)
1/8	1/2	SS-HPA-NS2-NS8	1.08 (27.4)	0.87 (22.2)	0.41 (10.4)	0.75 (19.1)	0.31 (8.0)	15000 (1034)
1/8	3/4	SS-HPA-NS2-NS12	1.08 (27.4)	1.06 (27.0)	0.41 (10.4)	0.75 (19.1)	0.31 (8.0)	10000 (690)
1/4	1/8	SS-HPA-NS4-NS2	1.25 (31.8)	0.94 (23.8)	0.59 (15.0)	0.38 (9.7)	0.19 (4.8)	15000 (1034)
1/4	1/4	SS-HPA-NS4	1.37 (34.9)	0.94 (23.8)	0.59 (15.0)	0.56 (14.2)	0.25 (6.4)	15000 (1034)
1/4	3/8	SS-HPA-NS4-NS6	1.37 (34.9)	0.94 (23.8)	0.59 (15.0)	0.56 (14.2)	0.31 (7.9)	15000 (1034)
1/4	1/2	SS-HPA-NS4-NS8	1.58 (40.1)	0.94 (23.8)	0.59 (15.0)	0.75 (19.1)	0.38 (9.6)	15000 (1034)
1/4	3/4	SS-HPA-NS4-NS12	1.34 (34.1)	1.06 (27.0)	0.59 (15.0)	0.75 (19.1)	0.41 (10.4)	10000 (690)
1/4	1	SS-HPA-NS4-NS16	1.37 (34.8)	1.37 (34.9)	0.59 (15.0)	0.94 (23.9)	0.41 (10.4)	10000 (690)
3/8	1/4	SS-HPA-NS6-NS4	1.42 (36.0)	1.13 (28.6)	0.59 (15.0)	0.56 (14.2)	0.25 (6.4)	15000 (1034)
3/8	3/8	SS-HPA-NS6	1.42 (36.0)	1.13 (28.6)	0.59 (15.0)	0.56 (14.2)	0.31 (7.9)	15000 (1034)
3/8	1/2	SS-HPA-NS6-NS8	1.61 (41.0)	1.13 (28.6)	0.59 (15.0)	0.75 (19.1)	0.38 (9.6)	15000 (1034)
3/8	3/4	SS-HPA-NS6-NS12	1.61 (41.0)	1.06 (27.0)	0.59 (15.0)	0.75 (19.1)	0.54 (13.8)	10000 (690)
3/8	1	SS-HPA-NS6-NS16	1.47 (37.3)	1.37 (34.9)	0.59 (15.0)	0.94 (23.9)	0.54 (13.8)	10000 (690)
1/2	1/4	SS-HPA-NS8-NS4	1.72 (43.1)	1.37 (34.9)	0.78 (19.8)	0.56 (14.2)	0.25 (6.4)	15000 (1034)
1/2	3/8	SS-HPA-NS8-NS6	1.72 (43.1)	1.37 (34.9)	0.78 (19.8)	0.56 (14.2)	0.31 (7.9)	15000 (1034)
1/2	1/2	SS-HPA-NS8	1.89 (48.0)	1.37 (34.9)	0.78 (19.8)	0.75 (19.1)	0.38 (9.6)	15000 (1034)
1/2	3/4	SS-HPA-NS8-NS12	1.89 (48.0)	1.19 (30.2)	0.78 (19.8)	0.75 (19.1)	0.58 (14.8)	10000 (690)
1/2	1	SS-HPA-NS8-NS16	2.08 (52.8)	1.37 (34.9)	0.78 (19.8)	0.94 (23.9)	0.67 (17.0)	10000 (690)
3/4	1/2	SS-HPA-NS12-NS8	1.89 (48.1)	1.50 (38.1)	0.81 (20.6)	0.75 (19.1)	0.47 (11.9)	10000 (690)
3/4	3/4	SS-HPA-NS12	1.89 (48.1)	1.50 (38.1)	0.81 (20.6)	0.75 (19.1)	0.58 (14.8)	10000 (690)
3/4	1	SS-HPA-NS12-NS16	2.08 (52.9)	1.50 (38.1)	0.81 (20.6)	0.94 (23.9)	0.79 (20.0)	10000 (690)
1	1/2	SS-HPA-NS16-NS8	2.10 (53.3)	1.75 (44.5)	1.00 (25.4)	0.75 (19.1)	0.47 (11.9)	10000 (690)
1	3/4	SS-HPA-NS16-NS12	2.10 (53.3)	1.75 (44.5)	1.00 (25.4)	0.75 (19.1)	0.58 (14.8)	10000 (690)
1	1	SS-HPA-NS16	2.29 (58.1)	1.75 (44.5)	1.00 (25.4)	0.94 (23.9)	0.79 (20.0)	10000 (690)

Adapters

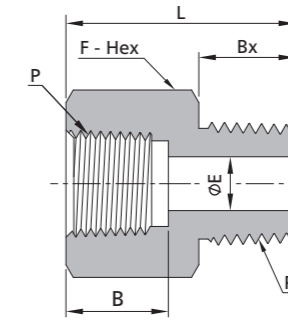

Female NPT Threads			Male ISO Tapered Threads					Working Pressure psig (bar)
P-NPT Size	Px-ISO Tapered Size	Ordering Number	Dimension, in. (mm)					
			L	F	B	Bx	E	
1/8	1/8	SS-HPA-NS2-RT2	0.96 (24.5)	0.63 (15.9)	0.41 (10.4)	0.38 (9.7)	0.19 (4.8)	15000 (1034)
1/8	1/4	SS-HPA-NS2-RT4	1.13 (28.8)	0.63 (15.9)	0.41 (10.4)	0.56 (14.2)	0.25 (6.4)	15000 (1034)
1/8	3/8	SS-HPA-NS2-RT6	1.14 (29.0)	0.69 (17.5)	0.41 (10.4)	0.56 (14.2)	0.31 (7.9)	15000 (1034)
1/8	1/2	SS-HPA-NS2-RT8	1.08 (27.4)	0.87 (22.2)	0.41 (10.4)	0.75 (19.1)	0.31 (8.0)	15000 (1034)
1/8	3/4	SS-HPA-NS2-RT12	1.08 (27.4)	1.06 (27.0)	0.41 (10.4)	0.75 (19.1)	0.31 (8.0)	10000 (690)
1/4	1/8	SS-HPA-NS4-RT2	1.25 (31.8)	0.94 (23.8)	0.59 (15.0)	0.38 (9.7)	0.19 (4.8)	15000 (1034)
1/4	1/4	SS-HPA-NS4-RT4	1.37 (34.9)	0.94 (23.8)	0.59 (15.0)	0.56 (14.2)	0.25 (6.4)	15000 (1034)
1/4	3/8	SS-HPA-NS4-RT6	1.37 (34.9)	0.94 (23.8)	0.59 (15.0)	0.56 (14.2)	0.31 (7.9)	15000 (1034)
1/4	1/2	SS-HPA-NS4-RT8	1.58 (40.1)	0.94 (23.8)	0.59 (15.0)	0.75 (19.1)	0.38 (9.6)	15000 (1034)
1/4	3/4	SS-HPA-NS4-RT12	1.34 (34.1)	1.06 (27.0)	0.59 (15.0)	0.75 (19.1)	0.41 (10.4)	10000 (690)
1/4	1	SS-HPA-NS4-RT16	1.37 (34.8)	1.37 (34.9)	0.59 (15.0)	0.94 (23.9)	0.41 (10.4)	10000 (690)
3/8	1/4	SS-HPA-NS6-RT4	1.42 (36.0)	1.13 (28.6)	0.59 (15.0)	0.56 (14.2)	0.25 (6.4)	15000 (1034)
3/8	3/8	SS-HPA-NS6-RT6	1.42 (36.0)	1.13 (28.6)	0.59 (15.0)	0.56 (14.2)	0.31 (7.9)	15000 (1034)
3/8	1/2	SS-HPA-NS6-RT8	1.61 (41.0)	1.13 (28.6)	0.59 (15.0)	0.75 (19.1)	0.38 (9.6)	15000 (1034)
3/8	3/4	SS-HPA-NS6-RT12	1.61 (41.0)	1.06(27.0)	0.59 (15.0)	0.75 (19.1)	0.54 (13.8)	10000 (690)
3/8	1	SS-HPA-NS6-RT16	1.47 (37.3)	1.37 (34.9)	0.59 (15.0)	0.94 (23.9)	0.54 (13.8)	10000 (690)
1/2	1/4	SS-HPA-NS8-RT4	1.72 (43.1)	1.37 (34.9)	0.78 (19.8)	0.56 (14.2)	0.25 (6.4)	15000 (1034)
1/2	3/8	SS-HPA-NS8-RT6	1.72 (43.1)	1.37 (34.9)	0.78 (19.8)	0.56 (14.2)	0.31 (7.9)	15000 (1034)
1/2	1/2	SS-HPA-NS8-RT8	1.89 (48.0)	1.37 (34.9)	0.78 (19.8)	0.75 (19.1)	0.38 (9.6)	15000 (1034)
1/2	3/4	SS-HPA-NS8-RT12	1.89 (48.0)	1.19 (30.2)	0.78 (19.8)	0.75 (19.1)	0.58 (14.8)	10000 (690)
1/2	1	SS-HPA-NS8-RT16	2.08 (52.8)	1.37 (34.9)	0.78 (19.8)	0.94 (23.9)	0.67 (17.0)	10000 (690)
3/4	1/2	SS-HPA-NS12-RT8	1.89 (48.1)	1.50 (38.1)	0.81 (20.6)	0.75 (19.1)	0.47 (11.9)	10000 (690)
3/4	3/4	SS-HPA-NS12-RT12	1.89 (48.1)	1.50 (38.1)	0.81 (20.6)	0.75 (19.1)	0.58 (14.8)	10000 (690)
3/4	1	SS-HPA-NS12-RT16	2.08 (52.9)	1.50 (38.1)	0.81 (20.6)	0.94 (23.9)	0.79 (20.0)	10000 (690)
1	1/2	SS-HPA-NS16-RT8	2.10 (53.3)	1.75 (44.5)	1.00 (25.4)	0.75 (19.1)	0.47 (11.9)	10000 (690)
1	3/4	SS-HPA-NS16-RT12	2.10 (53.3)	1.75 (44.5)	1.00 (25.4)	0.75 (19.1)	0.58 (14.8)	10000 (690)
1	1	SS-HPA-NS16-RT16	2.29 (58.1)	1.75 (44.5)	1.00 (25.4)	0.94 (23.9)	0.79 (20.0)	10000 (690)

Adapters

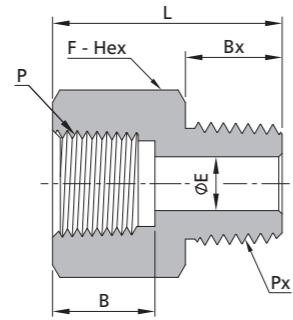

Female ISO Tapered Threads			Male ISO Tapered Threads					
P-ISO Tapered Size	Px-ISO Tapered Size	Ordering Number	Dimension, in. (mm)					Working Pressure psig (bar)
			L	F	B	Bx	E	
1/8	1/8	SS-HPA-RT2	0.96 (24.5)	0.63 (15.9)	0.41 (10.4)	0.38 (9.7)	0.19 (4.8)	15000 (1034)
1/8	1/4	SS-HPA-RT2-RT4	1.13 (28.8)	0.63 (15.9)	0.41 (10.4)	0.56 (14.2)	0.25 (6.4)	15000 (1034)
1/8	3/8	SS-HPA-RT2-RT6	1.14 (29.0)	0.69 (17.5)	0.41 (10.4)	0.56 (14.2)	0.31 (7.9)	15000 (1034)
1/8	1/2	SS-HPA-RT2-RT8	1.08 (27.4)	0.87 (22.2)	0.41 (10.4)	0.75 (19.1)	0.31 (8.0)	15000 (1034)
1/8	3/4	SS-HPA-RT2-RT12	1.08 (27.4)	1.06 (27.0)	0.41 (10.4)	0.75 (19.1)	0.31 (8.0)	10000 (690)
1/4	1/8	SS-HPA-RT4-RT2	1.25 (31.8)	0.94 (23.8)	0.59 (15.0)	0.38 (9.7)	0.19 (4.8)	15000 (1034)
1/4	1/4	SS-HPA-RT4	1.37 (34.9)	0.94 (23.8)	0.59 (15.0)	0.56 (14.2)	0.25 (6.4)	15000 (1034)
1/4	3/8	SS-HPA-RT4-RT6	1.37 (34.9)	0.94 (23.8)	0.59 (15.0)	0.56 (14.2)	0.31 (7.9)	15000 (1034)
1/4	1/2	SS-HPA-RT4-RT8	1.58 (40.1)	0.94 (23.8)	0.59 (15.0)	0.75 (19.1)	0.38 (9.6)	15000 (1034)
1/4	3/4	SS-HPA-RT4-RT12	1.34 (34.1)	1.06 (27.0)	0.59 (15.0)	0.75 (19.1)	0.41 (10.4)	10000 (690)
1/4	1	SS-HPA-RT4-RT16	1.37 (34.8)	1.37 (34.9)	0.59 (15.0)	0.94 (23.9)	0.41 (10.4)	10000 (690)
3/8	1/4	SS-HPA-RT6-RT4	1.42 (36.0)	1.13 (28.6)	0.59 (15.0)	0.56 (14.2)	0.25 (6.4)	15000 (1034)
3/8	3/8	SS-HPA-RT6	1.42 (36.0)	1.13 (28.6)	0.59 (15.0)	0.56 (14.2)	0.31 (7.9)	15000 (1034)
3/8	1/2	SS-HPA-RT6-RT8	1.61 (41.0)	1.13 (28.6)	0.59 (15.0)	0.75 (19.1)	0.38 (9.6)	15000 (1034)
3/8	3/4	SS-HPA-RT6-RT12	1.61 (41.0)	1.06 (27.0)	0.59 (15.0)	0.75 (19.1)	0.54 (13.8)	10000 (690)
3/8	1	SS-HPA-RT6-RT16	1.47 (37.3)	1.37 (34.9)	0.59 (15.0)	0.94 (23.9)	0.54 (13.8)	10000 (690)
1/2	1/4	SS-HPA-RT8-RT4	1.72 (43.1)	1.37 (34.9)	0.78 (19.8)	0.56 (14.2)	0.25 (6.4)	15000 (1034)
1/2	3/8	SS-HPA-RT8-RT6	1.72 (43.1)	1.37 (34.9)	0.78 (19.8)	0.56 (14.2)	0.31 (7.9)	15000 (1034)
1/2	1/2	SS-HPA-RT8	1.89 (48.0)	1.37 (34.9)	0.78 (19.8)	0.75 (19.1)	0.38 (9.6)	15000 (1034)
1/2	3/4	SS-HPA-RT8-RT12	1.89 (48.0)	1.19 (30.2)	0.78 (19.8)	0.75 (19.1)	0.58 (14.8)	10000 (690)
1/2	1	SS-HPA-RT8-RT16	2.08 (52.8)	1.37 (34.9)	0.78 (19.8)	0.94 (23.9)	0.69 (17.4)	10000 (690)
3/4	1/2	SS-HPA-RT12-RT8	1.89 (48.1)	1.50 (38.1)	0.81 (20.6)	0.75 (19.1)	0.47 (11.9)	10000 (690)
3/4	3/4	SS-HPA-RT12	1.89 (48.1)	1.50 (38.1)	0.81 (20.6)	0.75 (19.1)	0.58 (14.8)	10000 (690)
3/4	1	SS-HPA-RT12-RT16	2.08 (52.9)	1.50 (38.1)	0.81 (20.6)	0.94 (23.9)	0.79 (20.0)	10000 (690)
1	1/2	SS-HPA-RT16-RT8	2.10 (53.3)	1.75 (44.5)	1.00 (25.4)	0.75 (19.1)	0.47 (11.9)	10000 (690)
1	3/4	SS-HPA-RT16-RT12	2.10 (53.3)	1.75 (44.5)	1.00 (25.4)	0.75 (19.1)	0.58 (14.8)	10000 (690)
1	1	SS-HPA-RT16	2.29 (58.1)	1.75 (44.5)	1.00 (25.4)	0.94 (23.9)	0.79 (20.0)	10000 (690)

Adapters

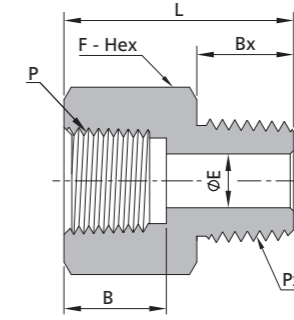

Female ISO Tapered Threads			Male NPT Threads					
P-ISO Tapered Size	Px-NPT Size	Ordering Number	Dimension, in. (mm)					Working Pressure psig (bar)
			L	F	B	Bx	E	
1/8	1/8	SS-HPA-RT2-NS2	0.96 (24.5)	0.63 (15.9)	0.41 (10.4)	0.38 (9.7)	0.19 (4.8)	15000 (1034)
1/8	1/4	SS-HPA-RT2-NS4	1.13 (28.8)	0.63 (15.9)	0.41 (10.4)	0.56 (14.2)	0.25 (6.4)	15000 (1034)
1/8	3/8	SS-HPA-RT2-NS6	1.14 (29.0)	0.69 (17.5)	0.41 (10.4)	0.56 (14.2)	0.31 (7.9)	15000 (1034)
1/8	1/2	SS-HPA-RT2-NS8	1.08 (27.4)	0.87 (22.2)	0.41 (10.4)	0.75 (19.1)	0.31 (8.0)	15000 (1034)
1/8	3/4	SS-HPA-RT2-NS12	1.08 (27.4)	1.06 (27.0)	0.41 (10.4)	0.75 (19.1)	0.31 (8.0)	10000 (690)
1/4	1/8	SS-HPA-RT4-NS2	1.25 (31.8)	0.94 (23.8)	0.59 (15.0)	0.38 (9.7)	0.19 (4.8)	15000 (1034)
1/4	1/4	SS-HPA-RT4-NS4	1.37 (34.9)	0.94 (23.8)	0.59 (15.0)	0.56 (14.2)	0.25 (6.4)	15000 (1034)
1/4	3/8	SS-HPA-RT4-NS6	1.37 (34.9)	0.94 (23.8)	0.59 (15.0)	0.56 (14.2)	0.31 (7.9)	15000 (1034)
1/4	1/2	SS-HPA-RT4-NS8	1.58 (40.1)	0.94 (23.8)	0.59 (15.0)	0.75 (19.1)	0.38 (9.6)	15000 (1034)
1/4	3/4	SS-HPA-RT4-NS12	1.34 (34.1)	1.06 (27.0)	0.59 (15.0)	0.75 (19.1)	0.41 (10.4)	10000 (690)
1/4	1	SS-HPA-RT4-NS16	1.37 (34.8)	1.37 (34.9)	0.59 (15.0)	0.94 (23.9)	0.41 (10.4)	10000 (690)
3/8	1/4	SS-HPA-RT6-NS4	1.42 (36.0)	1.13 (28.6)	0.59 (15.0)	0.56 (14.2)	0.25 (6.4)	15000 (1034)
3/8	3/8	SS-HPA-RT6-NS6	1.42 (36.0)	1.13 (28.6)	0.59 (15.0)	0.56 (14.2)	0.31 (7.9)	15000 (1034)
3/8	1/2	SS-HPA-RT6-NS8	1.61 (41.0)	1.13 (28.6)	0.59 (15.0)	0.75 (19.1)	0.38 (9.6)	15000 (1034)
3/8	3/4	SS-HPA-RT6-NS12	1.61 (41.0)	1.06 (27.0)	0.59 (15.0)	0.75 (19.1)	0.54 (13.8)	10000 (690)
3/8	1	SS-HPA-RT6-NS16	1.47 (37.3)	1.37 (34.9)	0.59 (15.0)	0.94 (23.9)	0.54 (13.8)	10000 (690)
1/2	1/4	SS-HPA-RT8-NS4	1.72 (43.1)	1.37 (34.9)	0.78 (19.8)	0.56 (14.2)	0.25 (6.4)	15000 (1034)
1/2	3/8	SS-HPA-RT8-NS6	1.72 (43.1)	1.37 (34.9)	0.78 (19.8)	0.56 (14.2)	0.31 (7.9)	15000 (1034)
1/2	1/2	SS-HPA-RT8-NS8	1.89 (48.0)	1.37 (34.9)	0.78 (19.8)	0.75 (19.1)	0.38 (9.6)	15000 (1034)
1/2	3/4	SS-HPA-RT8-NS12	1.89 (48.0)	1.19 (30.2)	0.78 (19.8)	0.75 (19.1)	0.58 (14.8)	10000 (690)
1/2	1	SS-HPA-RT8-NS16	2.08 (52.8)	1.37 (34.9)	0.78 (19.8)	0.94 (23.9)	0.69 (17.4)	10000 (690)
3/4	1/2	SS-HPA-RT12-NS8	1.89 (48.1)	1.50 (38.1)	0.81 (20.6)	0.75 (19.1)	0.47 (11.9)	10000 (690)
3/4	3/4	SS-HPA-RT12-NS12	1.89 (48.1)	1.50 (38.1)	0.81 (20.6)	0.75 (19.1)	0.58 (14.8)	10000 (690)
3/4	1	SS-HPA-RT12-NS16	2.08 (52.9)	1.50 (38.1)	0.81 (20.6)	0.94 (23.9)	0.79 (20.0)	10000 (690)
1	1/2	SS-HPA-RT16-NS8	2.10 (53.3)	1.75 (44.5)	1.00 (25.4)	0.75 (19.1)	0.47 (11.9)	10000 (690)
1	3/4	SS-HPA-RT16-NS12	2.10 (53.3)	1.75 (44.5)	1.00 (25.4)	0.75 (19.1)	0.58 (14.8)	10000 (690)
1	1	SS-HPA-RT16-NS16	2.29 (58.1)	1.75 (44.5)	1.00 (25.4)	0.94 (23.9)	0.79 (20.0)	10000 (690)

Adapters

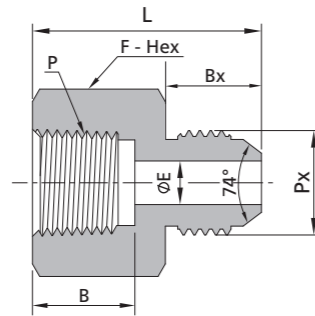

Female NPT Threads			Male JIC					
P-NPT Size	Px-SAE/MS Thread Size	Ordering Number	Dimension, in. (mm)					Working Pressure psig (bar)
			L	F	B	Bx	E	
1/8	7/16-20	SS-HPA-NS2-AN4	1.09 (27.8)	0.63 (15.9)	0.41 (10.4)	0.55 (14.0)	0.17 (4.4)	15000 (1034)
1/4	7/16-20	SS-HPA-NS4-AN4	1.32 (33.5)	0.94 (23.8)	0.59 (15.0)	0.55 (14.0)	0.17 (4.4)	15000 (1034)
1/4	9/16-18	SS-HPA-NS4-AN6	1.32 (33.5)	0.94 (23.8)	0.59 (15.0)	0.56 (14.1)	0.23 (5.8)	15000 (1034)
3/8	9/16-18	SS-HPA-NS6-AN6	1.37 (34.8)	1.13 (28.6)	0.59 (15.0)	0.56 (14.1)	0.23 (5.8)	15000 (1034)
3/8	3/4-16	SS-HPA-NS6-AN8	1.47 (37.4)	1.13 (28.6)	0.59 (15.0)	0.66 (16.7)	0.31 (8.0)	15000 (1034)
1/2	3/4-16	SS-HPA-NS8-AN8	1.72 (43.6)	1.37 (34.9)	0.78 (19.8)	0.66 (16.7)	0.31 (8.0)	15000 (1034)
1/2	7/8-14	SS-HPA-NS8-AN10	1.82 (46.2)	1.37 (34.9)	0.78 (19.8)	0.76 (19.3)	0.41 (10.4)	15000 (1034)
1/2	1 1/16-12	SS-HPA-NS8-AN12	1.92 (48.8)	1.37 (34.9)	0.78 (19.8)	0.86 (21.9)	0.46 (11.6)	15000 (1034)
3/4	1 1/16-12	SS-HPA-NS12-AN12	1.89 (47.9)	1.50 (38.1)	0.81 (20.6)	0.86 (21.9)	0.61 (15.5)	10000 (690)
1	1 5/16-12	SS-HPA-NS16-AN16	2.18 (55.3)	1.75 (44.5)	1.00 (25.4)	0.91 (23.1)	0.84 (21.4)	10000 (690)

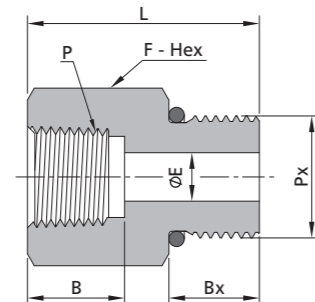

Female NPT Threads			Male SAE/MS Straight Threads					
P-NPT Size	Px-SAE/MS Thread Size	Ordering Number	Dimension, in. (mm)					Working Pressure psig (bar)
			L	F	B	Bx	E	
1/4	7/16-20	SS-HPA-NS4-SH7	1.20 (30.5)	0.75 (19.1)	0.59 (15.0)	0.43 (11.0)	0.18 (4.5)	10000 (690)
3/8	9/16-18	SS-HPA-NS6-SH9	1.29 (32.7)	0.94 (23.8)	0.59 (15.0)	0.47 (12.0)	0.30 (7.5)	10000 (690)
1/2	3/4-16	SS-HPA-NS8-SH12	1.61 (40.9)	1.19 (30.2)	0.78 (19.8)	0.55 (14.0)	0.39 (10.0)	10000 (690)
3/4	7/8-14	SS-HPA-NS12-SH14	1.67 (42.5)	1.50 (38.1)	0.81 (20.6)	0.63 (16.0)	0.49 (12.5)	10000 (690)

Adapters

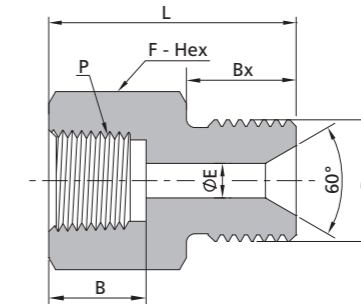

Female NPT Threads			Type "M" Male					
P-NPT Size	Px-SAE/MS Thread Size	Ordering Number	Dimension, in. (mm)					Working Pressure psig (bar)
			L	F	B	Bx	E	
1/8	9/16-18	SS-HPA-NS2-HM9	1.13 (28.6)	0.63 (15.9)	0.41 (10.4)	0.50 (12.7)	0.09 (2.4)	15000 (1034)
1/4	9/16-18	SS-HPA-NS4-HM9	1.37 (34.9)	0.94 (23.8)	0.59 (15.0)	0.50 (12.7)	0.09 (2.4)	15000 (1034)
1/4	3/4-16	SS-HPA-NS4-HM12	1.50 (38.1)	0.94 (23.8)	0.59 (15.0)	0.63 (16.0)	0.29 (7.4)	15000 (1034)
3/8	9/16-18	SS-HPA-NS6-HM9	1.44 (36.5)	1.13 (28.6)	0.59 (15.0)	0.50 (12.7)	0.09 (2.4)	15000 (1034)
3/8	3/4-16	SS-HPA-NS6-HM12	1.56 (39.7)	1.13 (28.6)	0.59 (15.0)	0.63 (16.0)	0.29 (7.4)	15000 (1034)
1/2	9/16-18	SS-HPA-NS8-HM9	1.63 (41.3)	1.37 (34.9)	0.78 (19.8)	0.50 (12.7)	0.09 (2.4)	15000 (1034)
1/2	3/4-16	SS-HPA-NS8-HM12	1.75 (44.4)	1.37 (34.9)	0.78 (19.8)	0.63 (16.0)	0.29 (7.4)	15000 (1034)
1/2	7/8-14	SS-HPA-NS8-HM14	1.87 (47.6)	1.37 (34.9)	0.78 (19.8)	0.76 (19.2)	0.15 (3.8)	15000 (1034)
3/4	1-12	SS-HPA-NS12-HM16	1.87 (47.6)	1.50 (38.1)	0.81 (20.6)	0.64 (16.3)	0.39 (10.0)	10000 (690)
1	1 5/16-12	SS-HPA-NS16-HM21	2.06 (52.4)	1.75 (44.5)	1.00 (25.4)	0.62 (15.7)	0.69 (17.5)	10000 (690)

Adapters

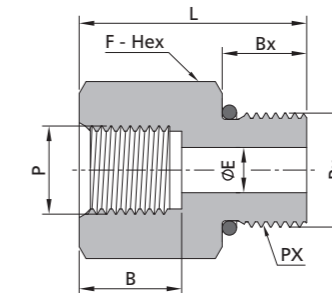

Female SAE/MS Straight Threads			Male SAE/MS Straight Threads					
P-SAE/MS Thread Size	Px-SAE/MS Thread Size	Ordering Number	Dimension, in. (mm)					Working Pressure psig (bar)
			L	F	B	Bx	E	
7/16-20	9/16-18	SS-HPA-US7-SH9	1.25 (31.8)	0.81 (20.6)	0.55 (14.0)	0.47 (12.0)	0.18 (4.5)	10000 (690)
7/16-20	3/4-16	SS-HPA-US7-SH12	1.25 (31.8)	0.87 (22.2)	0.55 (14.0)	0.55 (14.0)	0.18 (4.5)	10000 (690)
9/16-18	3/4-16	SS-HPA-US9-SH12	1.42 (36.0)	1.00 (25.4)	0.61 (15.5)	0.55 (14.0)	0.30 (7.5)	10000 (690)
9/16-18	7/8-14	SS-HPA-US9-SH14	1.42 (36.0)	1.00 (25.4)	0.61 (15.5)	0.63 (16.0)	0.30 (7.5)	10000 (690)
3/4-16	7/8-14	SS-HPA-US12-SH14	1.65 (41.8)	30.2 (30.2)	0.69 (17.5)	0.63 (16.0)	0.39 (10.0)	10000 (690)

Male Elbows

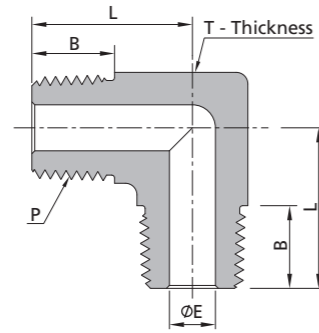

Male NPT Threads						
P-NPT Size	Ordering Number	Dimension, in. (mm)				Working Pressure psig (bar)
		L	B	E	T	
1/8	SS-HPME-NS2	0.75 (19.1)	0.38 (9.7)	0.19 (4.8)	0.50 (12.7)	15000 (1034)
1/4	SS-HPME-NS4	1.00 (25.4)	0.56 (14.2)	0.25 (6.4)	0.63 (15.9)	15000 (1034)
3/8	SS-HPME-NS6	1.10 (28.0)	0.56 (14.2)	0.31 (7.9)	0.75 (19.1)	15000 (1034)
1/2	SS-HPME-NS8	1.44 (36.6)	0.75 (19.1)	0.38 (9.6)	1.00 (25.4)	15000 (1034)
3/4	SS-HPME-NS12	1.56 (39.6)	0.75 (19.1)	0.58 (14.8)	1.37 (34.9)	10000 (690)
1	SS-HPME-NS16	1.89 (48.0)	0.94 (23.9)	0.79 (20.0)	1.50 (38.1)	10000 (690)

Male Elbows

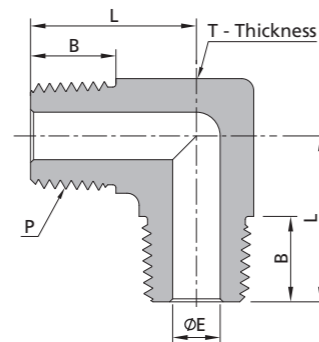

Male ISO Tapered Pipe Threads						
P-ISO Tapered Size	Ordering Number	Dimension, in. (mm)				Working Pressure psig (bar)
		L	B	E	T	
1/8	SS-HPME-RT2	0.75 (19.1)	0.38 (9.7)	0.19 (4.8)	0.50 (12.7)	15000 (1034)
1/4	SS-HPME-RT4	1.00 (25.4)	0.56 (14.2)	0.25 (6.4)	0.63 (15.9)	15000 (1034)
3/8	SS-HPME-RT6	1.10 (28.0)	0.56 (14.2)	0.31 (7.9)	0.75 (19.1)	15000 (1034)
1/2	SS-HPME-RT8	1.44 (36.6)	0.75 (19.1)	0.38 (9.6)	1.00 (25.4)	15000 (1034)
3/4	SS-HPME-RT12	1.56 (39.6)	0.75 (19.1)	0.58 (14.8)	1.37 (34.9)	10000 (690)
1	SS-HPME-RT16	1.89 (48.0)	0.94 (23.9)	0.79 (20.0)	1.50 (38.1)	10000 (690)

Street Elbows

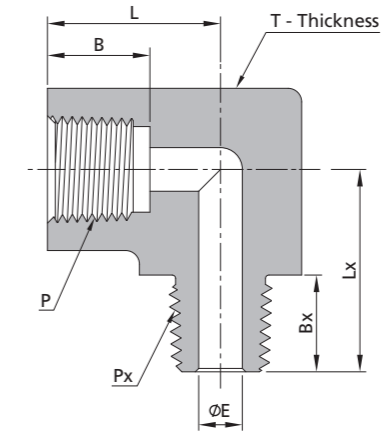

Female NPT Threads			Male NPT Threads						Working Pressure psig (bar)
P-NPT Size	Px-NPT Size	Ordering Number	Dimension, in. (mm)						
			L	B	E	Lx	Bx	T	
1/8	1/8	SS-HPSE-NS2	0.75 (19.1)	0.41 (10.4)	0.19 (4.8)	0.75 (19.1)	0.38 (9.7)	0.63 (15.9)	15000 (1034)
1/8	1/4	SS-HPSE-NS2-NS4	0.78 (19.8)	0.41 (10.4)	0.25 (6.4)	1.00 (25.4)	0.56 (14.2)	0.63 (15.9)	15000 (1034)
1/8	3/8	SS-HPSE-NS2-NS6	0.95 (24.2)	0.41 (10.4)	0.31 (7.9)	1.07 (27.2)	0.56 (14.2)	0.75 (19.1)	15000 (1034)
1/4	1/4	SS-HPSE-NS4	1.00 (25.4)	0.59 (15.0)	0.25 (6.4)	1.06 (27.0)	0.56 (14.2)	0.75 (19.1)	15000 (1034)
1/4	3/8	SS-HPSE-NS4-NS6	1.00 (25.4)	0.59 (15.0)	0.31 (7.9)	1.06 (27.0)	0.56 (14.2)	0.75 (19.1)	15000 (1034)
1/4	1/2	SS-HPSE-NS4-NS8	1.15 (29.1)	0.59 (15.0)	0.38 (9.6)	1.40 (35.5)	0.75 (19.1)	1.00 (25.4)	15000 (1034)
3/8	3/8	SS-HPSE-NS6	1.20 (30.6)	0.59 (15.0)	0.31 (7.9)	1.20 (30.6)	0.56 (14.2)	1.00 (25.4)	15000 (1034)
3/8	1/2	SS-HPSE-NS6-NS8	1.20 (30.6)	0.59 (15.0)	0.38 (9.6)	1.38 (35.0)	0.75 (19.1)	1.00 (25.4)	15000 (1034)
3/8	3/4	SS-HPSE-NS6-NS12	1.23 (31.2)	0.59 (15.0)	0.54 (13.8)	1.56 (39.6)	0.75 (19.1)	1.37 (34.9)	10000 (690)
1/2	1/2	SS-HPSE-NS8	1.50 (38.1)	0.78 (19.8)	0.38 (9.6)	1.61 (40.8)	0.75 (19.1)	1.37 (34.9)	15000 (1034)
1/2	3/4	SS-HPSE-NS8-NS12	1.43 (36.2)	0.78 (19.8)	0.58 (14.8)	1.61 (40.8)	0.75 (19.1)	1.37 (34.9)	10000 (690)
1/2	1	SS-HPSE-NS8-NS16	1.45 (36.9)	0.78 (19.8)	0.67 (17.0)	1.86 (47.3)	0.94 (23.9)	1.37 (34.9)	10000 (690)
3/4	3/4	SS-HPSE-NS12	1.50 (38.1)	0.81 (20.6)	0.58 (14.8)	1.77 (44.9)	0.75 (19.1)	1.50 (38.1)	10000 (690)
3/4	1	SS-HPSE-NS12-NS16	1.63 (41.4)	0.81 (20.6)	0.79 (20.0)	1.86 (47.3)	0.94 (23.9)	1.50 (38.1)	10000 (690)
1	1	SS-HPSE-NS16	1.91 (48.5)	1.00 (25.4)	0.79 (20.0)	2.07 (52.5)	0.94 (23.9)	1.75 (44.5)	10000 (690)

Street Elbows

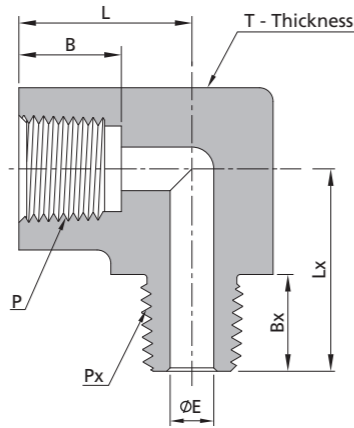

Female ISO Tapered Pipe Threads			Male ISO Tapered Threads						
P-ISO Tapered Size	Px-ISO Tapered Size	Ordering Number	Dimension, in. (mm)						Working Pressure psig (bar)
			L	B	E	Lx	Bx	T	
1/8	1/8	SS-HPSE-RT2	0.75 (19.1)	0.41 (10.4)	0.19 (4.8)	0.75 (19.1)	0.38 (9.7)	0.63 (15.9)	15000 (1034)
1/8	1/4	SS-HPSE-RT2-RT4	0.78 (19.8)	0.41 (10.4)	0.25 (6.4)	1.00 (25.4)	0.56 (14.2)	0.63 (15.9)	15000 (1034)
1/8	3/8	SS-HPSE-RT2-RT6	0.95 (24.2)	0.41 (10.4)	0.31 (7.9)	1.07 (27.2)	0.56 (14.2)	0.75 (19.1)	15000 (1034)
1/4	1/4	SS-HPSE-RT4	1.00 (25.4)	0.59 (15.0)	0.25 (6.4)	1.06 (27.0)	0.56 (14.2)	0.75 (19.1)	15000 (1034)
1/4	3/8	SS-HPSE-RT4-RT6	1.00 (25.4)	0.59 (15.0)	0.31 (7.9)	1.06 (27.0)	0.56 (14.2)	0.75 (19.1)	15000 (1034)
1/4	1/2	SS-HPSE-RT4-RT8	1.15 (29.1)	0.59 (15.0)	0.38 (9.6)	1.40 (35.5)	0.75 (19.1)	1.00 (25.4)	15000 (1034)
3/8	3/8	SS-HPSE-RT6	1.20 (30.6)	0.59 (15.0)	0.31 (7.9)	1.20 (30.6)	0.56 (14.2)	1.00 (25.4)	15000 (1034)
3/8	1/2	SS-HPSE-RT6-RT8	1.20 (30.6)	0.59 (15.0)	0.38 (9.6)	1.38 (35.0)	0.75 (19.1)	1.00 (25.4)	15000 (1034)
3/8	3/4	SS-HPSE-RT6-RT12	1.23 (31.2)	0.59 (15.0)	0.54 (13.8)	1.56 (39.6)	0.75 (19.1)	1.37 (34.9)	10000 (690)
1/2	1/2	SS-HPSE-RT8	1.50 (38.1)	0.78 (19.8)	0.38 (9.6)	1.61 (40.8)	0.75 (19.1)	1.37 (34.9)	15000 (1034)
1/2	3/4	SS-HPSE-RT8-RT12	1.43 (36.2)	0.78 (19.8)	0.58 (14.8)	1.61 (40.8)	0.75 (19.1)	1.37 (34.9)	10000 (690)
1/2	1	SS-HPSE-RT8-RT16	1.45 (36.9)	0.78 (19.8)	0.67 (17.0)	1.86 (47.3)	0.94 (23.9)	1.37 (34.9)	10000 (690)
3/4	3/4	SS-HPSE-RT12	1.50 (38.1)	0.81 (20.6)	0.58 (14.8)	1.77 (44.9)	0.75 (19.1)	1.50 (38.1)	10000 (690)
3/4	1	SS-HPSE-RT12-RT16	1.63 (41.4)	0.81 (20.6)	0.79 (20.0)	1.86 (47.3)	0.94 (23.9)	1.50 (38.1)	10000 (690)
1	1	SS-HPSE-RT16	1.91 (48.5)	1.00 (25.4)	0.79 (20.0)	2.07 (52.5)	0.94 (23.9)	1.75 (44.5)	10000 (690)

Female Elbows

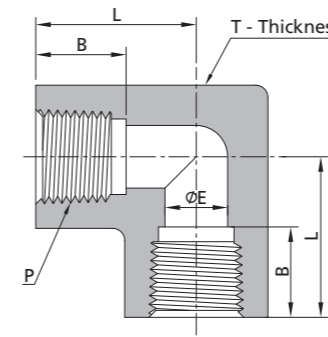

Female NPT Threads						
P-NPT Size	Ordering Number	Dimension, in. (mm)				Working Pressure psig (bar)
		L	B	E	T	
1/8	SS-HPE-NS2	0.75 (19.1)	0.41 (10.4)	0.31 (8.0)	0.63 (15.9)	15000 (1034)
1/4	SS-HPE-NS4	1.00 (25.4)	0.59 (15.0)	0.41 (10.4)	0.75 (19.1)	15000 (1034)
3/8	SS-HPE-NS6	1.20 (30.6)	0.59 (15.0)	0.54 (13.8)	1.00 (25.4)	15000 (1034)
1/2	SS-HPE-NS8	1.50 (38.1)	0.78 (19.8)	0.67 (17.0)	1.37 (34.9)	15000 (1034)
3/4	SS-HPE-NS12	1.50 (38.1)	0.81 (20.6)	0.88 (22.3)	1.50 (38.1)	10000 (690)
1	SS-HPE-NS16	1.91 (48.5)	1.00 (25.4)	1.11 (28.1)	1.75 (44.5)	10000 (690)

Female ISO Tapered Threads						
P-ISO Tapered Size	Ordering Number	Dimension, in. (mm)				Working Pressure psig (bar)
		L	B	E	T	
1/8	SS-HPE-RT2	0.75 (19.1)	0.41 (10.4)	0.31 (8.0)	0.63 (15.9)	15000 (1034)
1/4	SS-HPE-RT4	1.00 (25.4)	0.59 (15.0)	0.41 (10.4)	0.75 (19.1)	15000 (1034)
3/8	SS-HPE-RT6	1.20 (30.6)	0.59 (15.0)	0.54 (13.8)	1.00 (25.4)	15000 (1034)
1/2	SS-HPE-RT8	1.50 (38.1)	0.78 (19.8)	0.69 (17.4)	1.37 (34.9)	15000 (1034)
3/4	SS-HPE-RT12	1.50 (38.1)	0.81 (20.6)	0.90 (22.8)	1.50 (38.1)	10000 (690)
1	SS-HPE-RT16	1.91 (48.5)	1.00 (25.4)	1.13 (28.7)	1.75 (44.5)	10000 (690)

Male Tees

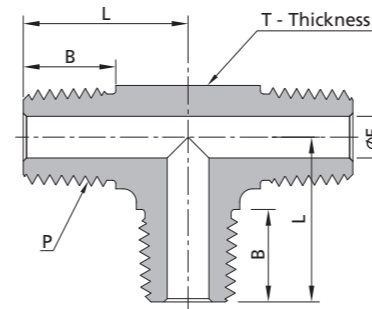

Male NPT Threads						
P-NPT Size	Ordering Number	Dimension, in. (mm)				Working Pressure psig (bar)
		L	B	E	T	
1/8	SS-HPMT-NS2	0.75 (19.1)	0.38 (9.7)	0.19 (4.8)	0.50 (12.7)	15000 (1034)
1/4	SS-HPMT-NS4	1.00 (25.4)	0.56 (14.2)	0.25 (6.4)	0.63 (15.9)	15000 (1034)
3/8	SS-HPMT-NS6	1.10 (28.0)	0.56 (14.2)	0.31 (7.9)	0.75 (19.1)	15000 (1034)
1/2	SS-HPMT-NS8	1.44 (36.6)	0.75 (19.1)	0.38 (9.6)	1.00 (25.4)	15000 (1034)
3/4	SS-HPMT-NS12	1.56 (39.6)	0.75 (19.1)	0.58 (14.8)	1.37 (34.9)	10000 (690)
1	SS-HPMT-NS16	1.89 (48.0)	0.94 (23.9)	0.79 (20.0)	1.50 (38.1)	10000 (690)

Male ISO Tapered Threads						
P-ISO Tapered Size	Ordering Number	Dimension, in. (mm)				Working Pressure psig (bar)
		L	B	E	T	
1/8	SS-HPMT-RT2	0.75 (19.1)	0.38 (9.7)	0.19 (4.8)	0.50 (12.7)	15000 (1034)
1/4	SS-HPMT-RT4	1.00 (25.4)	0.56 (14.2)	0.25 (6.4)	0.63 (15.9)	15000 (1034)
3/8	SS-HPMT-RT6	1.10 (28.0)	0.56 (14.2)	0.31 (7.9)	0.75 (19.1)	15000 (1034)
1/2	SS-HPMT-RT8	1.44 (36.6)	0.75 (19.1)	0.38 (9.6)	1.00 (25.4)	15000 (1034)
3/4	SS-HPMT-RT12	1.56 (39.6)	0.75 (19.1)	0.58 (14.8)	1.37 (34.9)	10000 (690)
1	SS-HPMT-RT16	1.89 (48.0)	0.94 (23.9)	0.79 (20.0)	1.50 (38.1)	10000 (690)

Male Street Tees

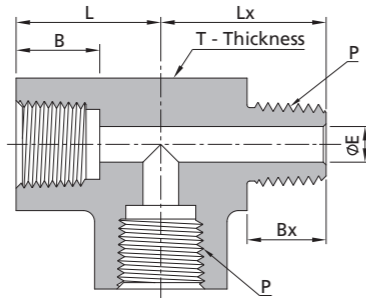

NPT Threads								
P-NPT Size	Ordering Number	Dimension, in. (mm)						Working Pressure psig (bar)
		L	B	Lx	Bx	E	T	
1/8	SS-HPST-NS2	0.75 (19.1)	0.41 (10.4)	0.75 (19.1)	0.38 (9.7)	0.19 (4.8)	0.63 (15.9)	15000 (1034)
1/4	SS-HPST-NS4	1.00 (25.4)	0.59 (15.0)	1.06 (27.0)	0.56 (14.2)	0.25 (6.4)	0.75 (19.1)	15000 (1034)
3/8	SS-HPST-NS6	1.20 (30.6)	0.59 (15.0)	1.20 (30.6)	0.56 (14.2)	0.31 (7.9)	1.00 (25.4)	15000 (1034)
1/2	SS-HPST-NS8	1.50 (38.1)	0.78 (19.8)	1.61 (40.8)	0.75 (19.1)	0.38 (9.6)	1.37 (34.9)	15000 (1034)
3/4	SS-HPST-NS12	1.50 (38.1)	0.81 (20.6)	1.77 (44.9)	0.75 (19.1)	0.58 (14.8)	1.50 (38.1)	10000 (690)
1	SS-HPST-NS16	1.91 (48.5)	1.00 (25.4)	2.07 (52.5)	0.94 (23.9)	0.79 (20.0)	1.75 (44.5)	10000 (690)

ISO Tapered Pipe Threads								
P-ISO Tapered Size	Ordering Number	Dimension, in. (mm)						Working Pressure psig (bar)
		L	B	Lx	Bx	E	T	
1/8	SS-HPST-RT2	0.75 (19.1)	0.41 (10.4)	0.75 (19.1)	0.38 (9.7)	0.19 (4.8)	0.63 (15.9)	15000 (1034)
1/4	SS-HPST-RT4	1.00 (25.4)	0.59 (15.0)	1.06 (27.0)	0.56 (14.2)	0.25 (6.4)	0.75 (19.1)	15000 (1034)
3/8	SS-HPST-RT6	1.20 (30.6)	0.59 (15.0)	1.20 (30.6)	0.56 (14.2)	0.31 (7.9)	1.00 (25.4)	15000 (1034)
1/2	SS-HPST-RT8	1.50 (38.1)	0.78 (19.8)	1.61 (40.8)	0.75 (19.1)	0.38 (9.6)	1.37 (34.9)	15000 (1034)
3/4	SS-HPST-RT12	1.50 (38.1)	0.81 (20.6)	1.77 (44.9)	0.75 (19.1)	0.58 (14.8)	1.50 (38.1)	10000 (690)
1	SS-HPST-RT16	1.91 (48.5)	1.00 (25.4)	2.07 (52.5)	0.94 (23.9)	0.79 (20.0)	1.75 (44.5)	10000 (690)

Male Branch Tees

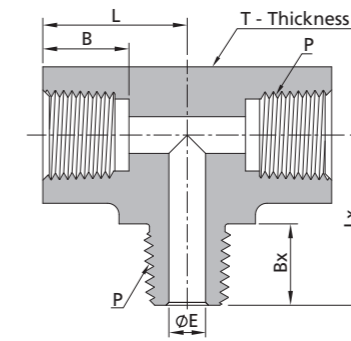

NPT Threads								
P-NPT Size	Ordering Number	Dimension, in. (mm)						Working Pressure psig (bar)
		L	B	Lx	Bx	E	T	
1/8	SS-HPBT-NS2	0.75 (19.1)	0.41 (10.4)	0.75 (19.1)	0.38 (9.7)	0.19 (4.8)	0.63 (15.9)	15000 (1034)
1/4	SS-HPBT-NS4	1.00 (25.4)	0.59 (15.0)	1.06 (27.0)	0.56 (14.2)	0.25 (6.4)	0.75 (19.1)	15000 (1034)
3/8	SS-HPBT-NS6	1.20 (30.6)	0.59 (15.0)	1.20 (30.6)	0.56 (14.2)	0.31 (7.9)	1.00 (25.4)	15000 (1034)
1/2	SS-HPBT-NS8	1.50 (38.1)	0.78 (19.8)	1.61 (40.8)	0.75 (19.1)	0.38 (9.6)	1.37 (34.9)	15000 (1034)
3/4	SS-HPBT-NS12	1.50 (38.1)	0.81 (20.6)	1.77 (44.9)	0.75 (19.1)	0.58 (14.8)	1.50 (38.1)	10000 (690)
1	SS-HPBT-NS16	1.91 (48.5)	1.00 (25.4)	2.07 (52.5)	0.94 (23.9)	0.79 (20.0)	1.75 (44.5)	10000 (690)

ISO Tapered Pipe Threads								
P-ISO Tapered Size	Ordering Number	Dimension, in. (mm)						Working Pressure psig (bar)
		L	B	Lx	Bx	E	T	
1/8	SS-HPBT-RT2	0.75 (19.1)	0.41 (10.4)	0.75 (19.1)	0.38 (9.7)	0.19 (4.8)	0.63 (15.9)	15000 (1034)
1/4	SS-HPBT-RT4	1.00 (25.4)	0.59 (15.0)	1.06 (27.0)	0.56 (14.2)	0.25 (6.4)	0.75 (19.1)	15000 (1034)
3/8	SS-HPBT-RT6	1.20 (30.6)	0.59 (15.0)	1.20 (30.6)	0.56 (14.2)	0.31 (7.9)	1.00 (25.4)	15000 (1034)
1/2	SS-HPBT-RT8	1.50 (38.1)	0.78 (19.8)	1.61 (40.8)	0.75 (19.1)	0.38 (9.6)	1.37 (34.9)	15000 (1034)
3/4	SS-HPBT-RT12	1.50 (38.1)	0.81 (20.6)	1.77 (44.9)	0.75 (19.1)	0.58 (14.8)	1.50 (38.1)	10000 (690)
1	SS-HPBT-RT16	1.91 (48.5)	1.00 (25.4)	2.07 (52.5)	0.94 (23.9)	0.79 (20.0)	1.75 (44.5)	10000 (690)

Female Tees

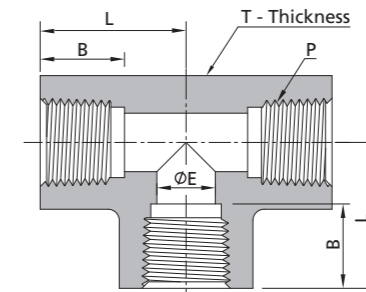

Female NPT Threads						
P-NPT Size	Ordering Number	Dimension, in. (mm)				Working Pressure psig (bar)
		L	B	E	T	
1/8	SS-HPT-NS2	0.75 (19.1)	0.41 (10.4)	0.31 (8.0)	0.63 (15.9)	15000 (1034)
1/4	SS-HPT-NS4	1.00 (25.4)	0.59 (15.0)	0.41 (10.4)	0.75 (19.1)	15000 (1034)
3/8	SS-HPT-NS6	1.20 (30.6)	0.59 (15.0)	0.54 (13.8)	1.00 (25.4)	15000 (1034)
1/2	SS-HPT-NS8	1.50 (38.1)	0.78 (19.8)	0.67 (17.0)	1.37 (34.9)	15000 (1034)
3/4	SS-HPT-NS12	1.50 (38.1)	0.81 (20.6)	0.88 (22.3)	1.50 (38.1)	10000 (690)
1	SS-HPT-NS16	1.91 (48.5)	1.00 (25.4)	1.11 (28.1)	1.75 (44.5)	10000 (690)

Female ISO Tapered Pipe Threads						
P-ISO Tapered Size	Ordering Number	Dimension, in. (mm)				Working Pressure psig (bar)
		L	B	E	T	
1/8	SS-HPT-RT2	0.75 (19.1)	0.41 (10.4)	0.31 (8.0)	0.63 (15.9)	15000 (1034)
1/4	SS-HPT-RT4	1.00 (25.4)	0.59 (15.0)	0.41 (10.4)	0.75 (19.1)	15000 (1034)
3/8	SS-HPT-RT6	1.20 (30.6)	0.59 (15.0)	0.54 (13.8)	1.00 (25.4)	15000 (1034)
1/2	SS-HPT-RT8	1.50 (38.1)	0.78 (19.8)	0.69 (17.4)	1.37 (34.9)	15000 (1034)
3/4	SS-HPT-RT12	1.50 (38.1)	0.81 (20.6)	0.90 (22.8)	1.50 (38.1)	10000 (690)
1	SS-HPT-RT16	1.91 (48.5)	1.00 (25.4)	1.13 (28.7)	1.75 (44.5)	10000 (690)

Female Crosses

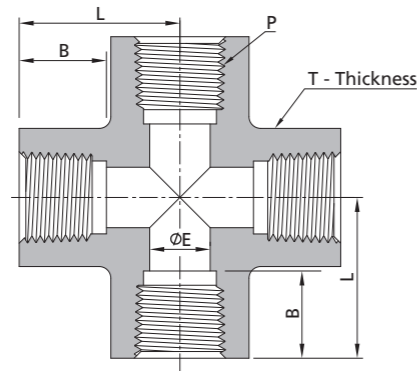

Female NPT Threads						
P-NPT Size	Ordering Number	Dimension, in. (mm)				Working Pressure psig (bar)
		L	B	E	T	
1/8	SS-HPCR-NS2	0.75 (19.1)	0.41 (10.4)	0.31 (8.0)	0.63 (15.9)	15000 (1034)
1/4	SS-HPCR-NS4	1.00 (25.4)	0.59 (15.0)	0.41 (10.4)	0.75 (19.1)	15000 (1034)
3/8	SS-HPCR-NS6	1.20 (30.6)	0.59 (15.0)	0.54 (13.8)	1.00 (25.4)	15000 (1034)
1/2	SS-HPCR-NS8	1.50 (38.1)	0.78 (19.8)	0.67 (17.0)	1.37 (34.9)	15000 (1034)
3/4	SS-HPCR-NS12	1.50 (38.1)	0.81 (20.6)	0.88 (22.3)	1.50 (38.1)	10000 (690)
1	SS-HPCR-NS16	1.91 (48.5)	1.00 (25.4)	1.11 (28.1)	1.75 (44.5)	10000 (690)

Female ISO Tapered Pipe Threads						
P-ISO Tapered Size	Ordering Number	Dimension, in. (mm)				Working Pressure psig (bar)
		L	B	E	T	
1/8	SS-HPCR-RT2	0.75 (19.1)	0.41 (10.4)	0.31 (8.0)	0.63 (15.9)	15000 (1034)
1/4	SS-HPCR-RT4	1.00 (25.4)	0.59 (15.0)	0.41 (10.4)	0.75 (19.1)	15000 (1034)
3/8	SS-HPCR-RT6	1.20 (30.6)	0.59 (15.0)	0.54 (13.8)	1.00 (25.4)	15000 (1034)
1/2	SS-HPCR-RT8	1.50 (38.1)	0.78 (19.8)	0.69 (17.4)	1.37 (34.9)	15000 (1034)
3/4	SS-HPCR-RT12	1.50 (38.1)	0.81 (20.6)	0.90 (22.8)	1.50 (38.1)	10000 (690)
1	SS-HPCR-RT16	1.91 (48.5)	1.00 (25.4)	1.13 (28.7)	1.75 (44.5)	10000 (690)

Part Number Description

